

EXTENDO  
DESIGN SOURCE

# living systems

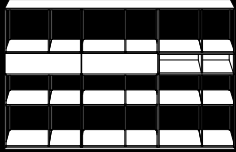

## atelier

AT02 pg. 12  
AT03 pg. 14  
AT01 pg. 16  
AT04 pg. 18  
AT06 pg. 20  
AT05 pg. 22

AT07 pg. 24  
AT08 pg. 25

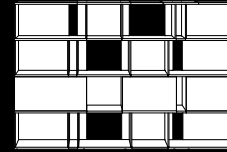

## from>to

FT30 pg. 80  
FT02 pg. 82  
FT03 pg. 84  
FT01 pg. 86  
FT05A pg. 88  
FT04 pg. 90



## monolith

MN03 pg. 30  
MN09 pg. 32  
MN08 pg. 36  
MN02C pg. 38  
MN02B pg. 39  
MN06A pg. 40

MN06B pg. 41  
MN04 pg. 42  
MN01 pg. 44  
MN02A pg. 46  
MN05 pg. 48



## system

SY54 pg. 96  
SY13 pg. 100  
SY03 pg. 102  
SY04 pg. 104  
SY16 pg. 106  
SY14 pg. 107

SY02 pg. 108  
SY52 pg. 112  
SY53 pg. 114

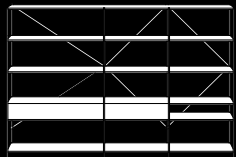

## XY

XY30 pg. 54  
XY31 pg. 58  
XY29 pg. 60  
XY28 pg. 64  
XY02 pg. 66  
XY10 pg. 68

XY08 pg. 69  
XY09 pg. 70  
XY03 pg. 72  
XY15 pg. 74

# tables and coffee tables



## balance

BA08 pg. 120  
BA02 pg. 122  
BA03 pg. 123  
BA01 pg. 124  
BA04 pg. 126  
BA06 pg. 128  
BA05 pg. 130  
BA07 pg. 132



## danske T

DT01 pg. 196  
DT02 pg. 198



## spillo

SP24 pg. 136  
SP21 pg. 138  
SP05 pg. 140  
SP20 pg. 141  
SP25 pg. 142  
SP03 pg. 144  
SP19 pg. 145  
SP22 pg. 146  
SP04 pg. 148

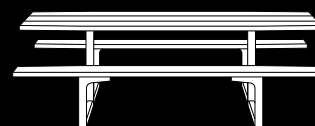

## hammer

HA04 pg. 202  
HA05 pg. 204  
HA06 pg. 206  
HA03 pg. 208  
HA02 pg. 209



## sintesi

ST01 pg. 154  
ST02 pg. 156  
ST06 pg. 158  
ST03 pg. 162  
ST04 pg. 166  
ST05 pg. 167



## mr. hyde

MH28 pg. 212  
MH29 pg. 214



## T7

T701 pg. 170  
T702 pg. 172



## spillo

SP26 pg. 150



## T8

T801 pg. 176  
T803 pg. 178  
T804 pg. 182  
T802 pg. 184



## déco

DE03 pg. 222  
DE06 pg. 223  
DE01 pg. 224  
DE05 pg. 225  
DE02 pg. 226  
DE04 pg. 227



## IPE

IP01 pg. 188  
IP03 pg. 190  
IP02 pg. 192



## mr.hyde

MH01 pg. 216  
MH07 pg. 217  
MH02 pg. 218

# seating



**viking K**

VK01 pg. 232



**viking W**

VK02 pg. 236



**viking L**

VK03 pg. 238

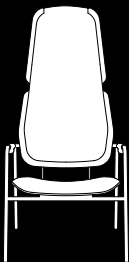

**viking GL**

VK04 pg. 240



**danske C1**

DC01 pg. 246



**danske C2**

DC02 pg. 248



**danske C3**

DC04 pg. 252  
DC03 pg. 254



# multimedia

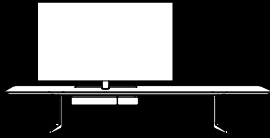

## connect

CN01 pg. 260  
CN02 pg. 264

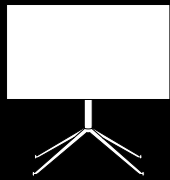

## apollo

AP01 pg. 268

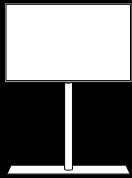

## spin360

SN01 pg. 274

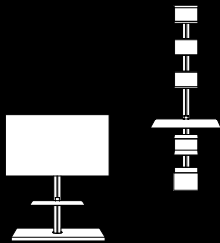

## girogiro-system

SY55 pg. 280  
SY20C pg. 282  
SY23 pg. 284  
SY18 pg. 286  
SY17 pg. 287

# walk in closet

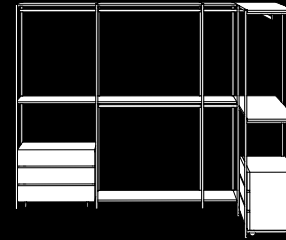

## slide

SL01 pg. 294  
SL04 pg. 298  
SL03 pg. 302  
SL02 pg. 304

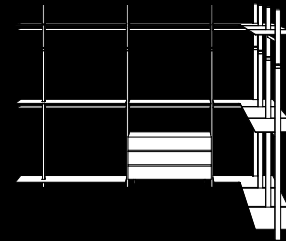

## personal

PE01 pg. 310  
PE02 pg. 314  
PE03 pg. 318  
PE04 pg. 322  
PE05 pg. 324  
PE06 pg. 326  
PE07 pg. 328  
PE08 pg. 332  
PE09 pg. 334

# living systems



**atelier**

pg. 08

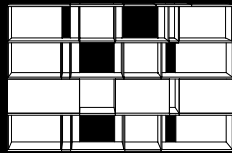

**from>to**

pg. 76



**monolith**

pg. 26



**system**

pg. 92

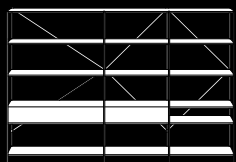

**XY**

pg. 50



GIOVANNI BELLINI

175 Marzo/March 2005

LOTTO

TASCHEN  
100 CONTEMPORARY HOUSES



100 INTERIORS AROUND THE WORLD

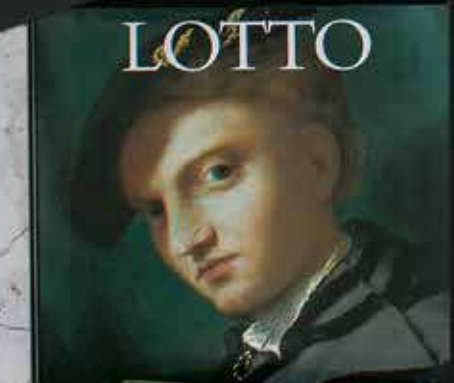

SCANDINAVIAN FURNITURE

bookshelf

UN'INDUSTRIA PER IL DESIGN  
AN INDUSTRY FOR DESIGN

100 CONTEMPORARY HOUSES  
100 INTERIORS AROUND THE WORLD

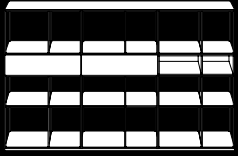

# atelier

**Atelier è configurabile utilizzando moduli in acciaio con sezione minima di 10x10mm e contenitori in legno con diverse tipologie di aperture. Telai e contenitori possono essere sovrapposti e affiancati a piacimento, posizionati su basi o sospesi a parete. Sono disponibili accessori da inserire all'interno dei telai e top in HPL o marmo.**

Atelier can be configured using modular elements in steel with a minimum 10x10mm cross-section as well as wooden containers with several different types of openings. Both frames and containers can be stacked and placed side by side as desired, either installed onto support bases or wall-mounted. Accessories to be integrated into the HPL or marble frames and tops.

Atelier peut être configuré en utilisant des modules en acier avec une section minimum de 10x10 mm et des bacs en bois avec plusieurs typologies d'ouvertures. Châssis et bacs peuvent être superposés et associés à loisir, positionnés sur des bases ou suspendus au mur. Des accessoires sont disponibles pour l'insertion à l'intérieur des châssis et plateau en HPL ou marbre.

Bei der modularen Serie Atelier lassen sich Stahlmodule mit einer Mindeststärke von 10x10 mm mit Holzbehältern verschiedener Arten und Öffnungen kombinieren. Gestelle und Behälter können übereinander oder nebeneinander angeordnet, auf einen Unterbau gestellt oder an der Wand aufgehängt werden. Verschiedene Einsätze für die Gestelle sowie Abschlussplatten aus HPL oder Marmor als Zubehör erhältlich.

Atelier se puede configurar utilizando módulos de acero con sección mínima de 10x10mm, así como contenedores de madera con distintos tipos de aperturas. Bastidores y contenedores, pueden colocarse uno encima del otro o uno al lado del otro, según se prefiera, posicionados sobre bases o colgados en la pared. Están disponibles accesorios que se pueden introducir en el interior de los bastidores y encimeras de laminado de alta presión (HPL) o mármol.



## materiali / materials



acciaio  
steel  
acier  
Stahl  
acero



HPL



vetro  
glass  
verre  
Glas  
cristal



MDF  
DM



Le materie prime che costituiscono il sistema atelier derivano da un processo di riutilizzo e sono a loro volta riciclabili.

The primary materials used in the system atelier are sourced from a reuse process, and are in turn recyclable.

Les matières premières qui composent le système atelier dérivent d'un processus de réutilisation et sont à leur tour recyclables.

Die Rohstoffe für das System atelier entstammen einem Wiederverwertungsprozess und sind Ihrerseits wiederum recyclebar.

Las materias primas que constituyen el sistema atelier proceden de un proceso de reutilización y son, a su vez, reciclables.





telaio / structure / châssis / Gestell / bastidor

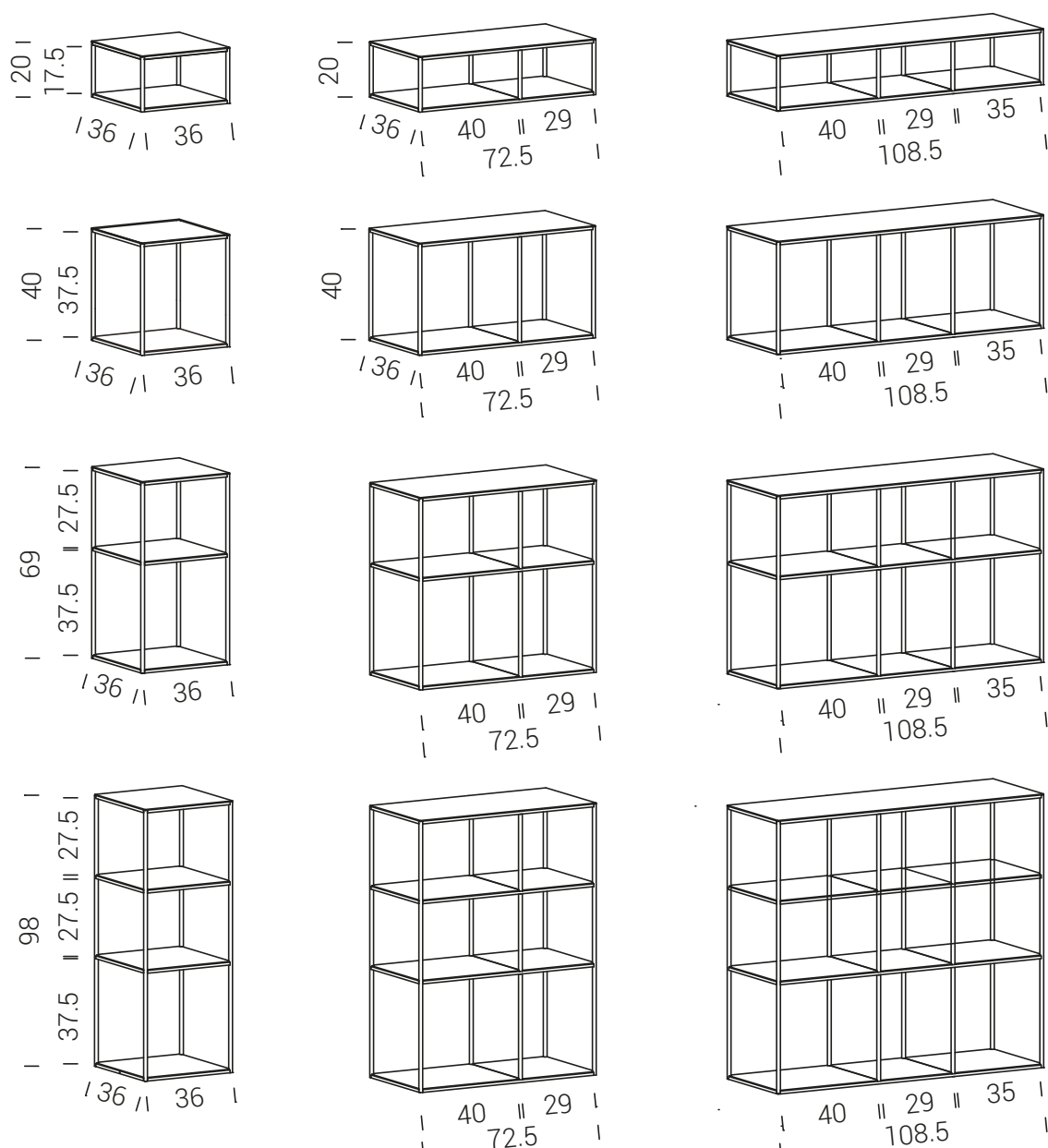

base / base / base / Basis / base

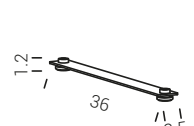
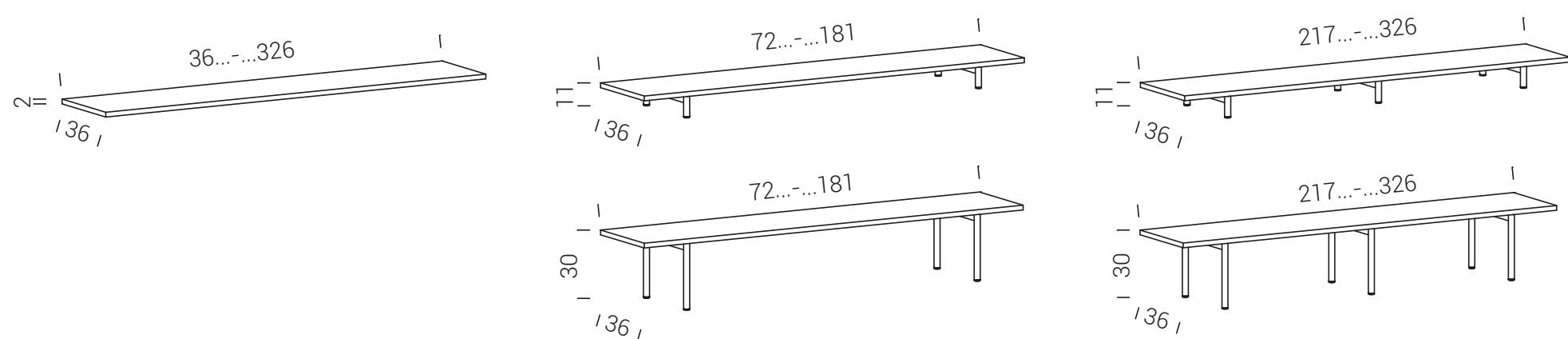

basi per moduli in acciaio outdoor / bases for outdoor steel modules  
 bases pour modules en acier pour extérieur / Sockel für Outdoor-Stahlmodule  
 bases para módulos de acero para exteriores

contenitori / cabinets / modules de rangement / Behälter / contenedores

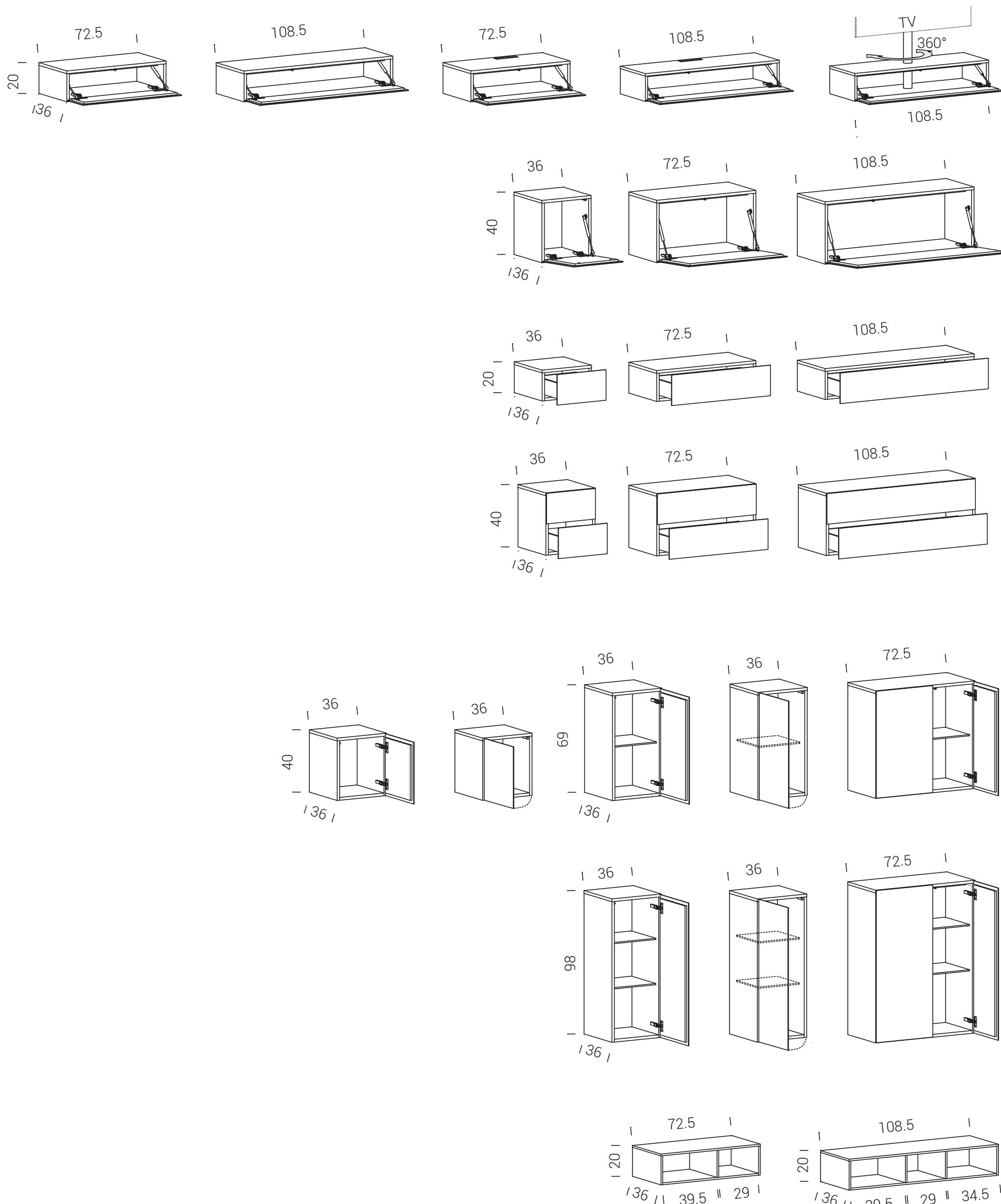

moduli interni / internal modules / modules internes / interne Module / módulos internos



piano / top / plateau / platte / sobre

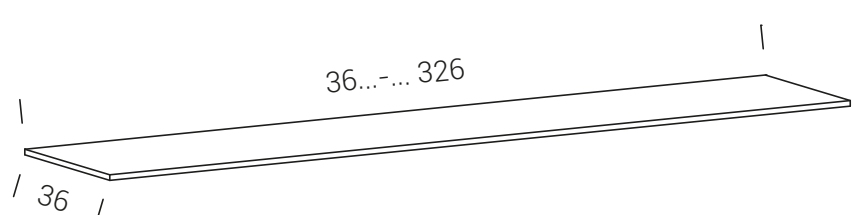

ripiani a parete / wall shelves / tablettes murals / Wandregale / estantes a pared

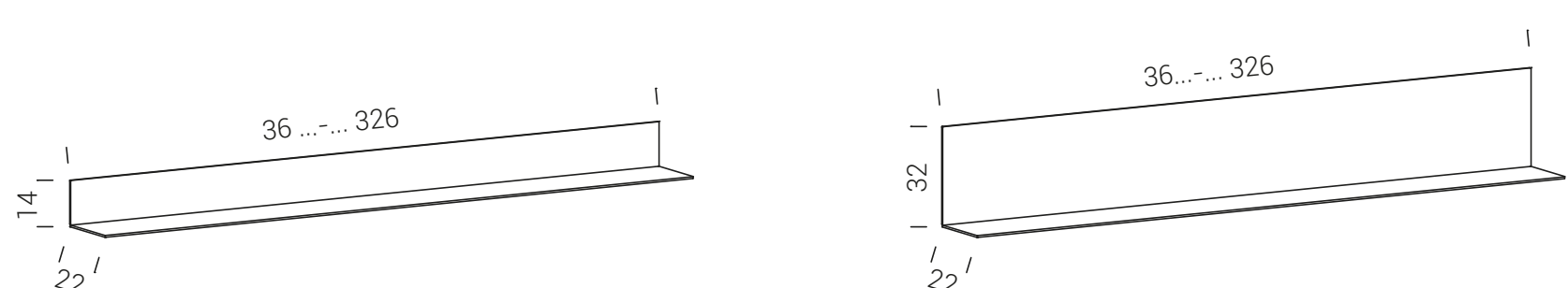

**telaio / structure / châssis / Gestell / bastidor**

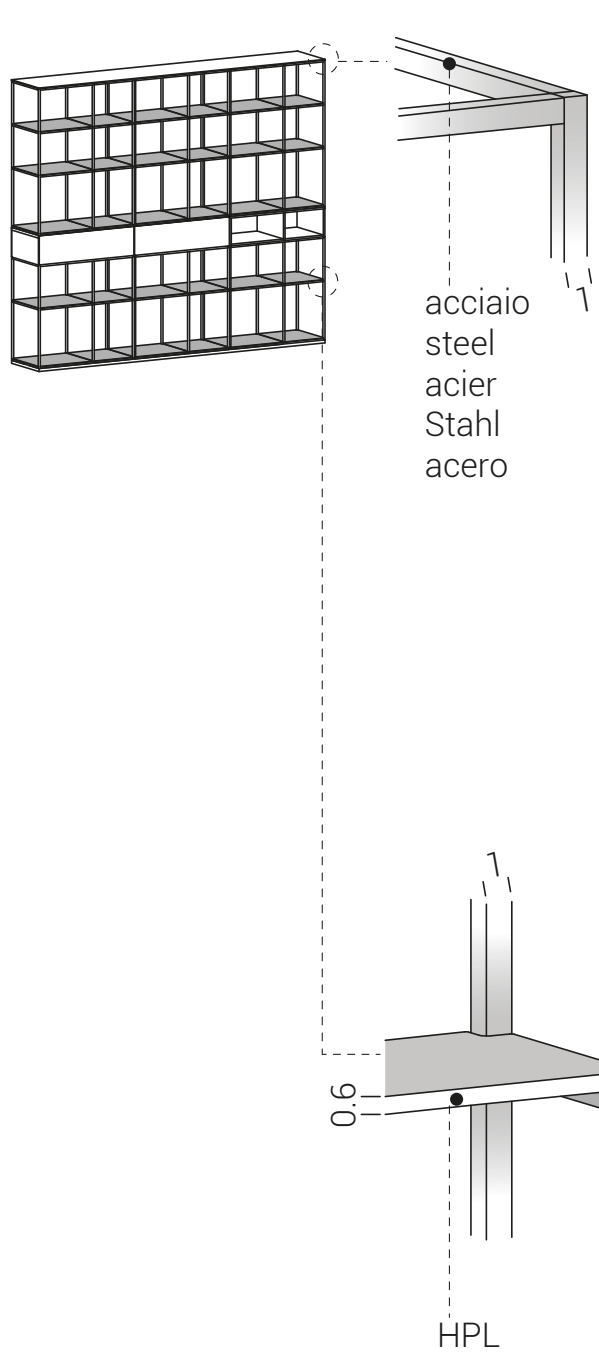

verniciato  
painted  
peint  
lackierter  
pintado

|  |            |                    |
|--|------------|--------------------|
|  | <b>C12</b> | bianco<br>white    |
|  | <b>C21</b> | seta<br>silk       |
|  | <b>C23</b> | corda<br>ecru      |
|  | <b>C30</b> | ghisa<br>cast-iron |

|  |            |                         |
|--|------------|-------------------------|
|  | <b>C14</b> | antracite<br>anthracite |
|  | <b>C08</b> | nero<br>black           |
|  | <b>C29</b> | bronzo<br>bronze        |

HPL

|  |            |                              |
|--|------------|------------------------------|
|  | <b>L03</b> | bianco<br>white              |
|  | <b>L08</b> | grigio Londra<br>London grey |
|  | <b>L06</b> | nero<br>black                |

laccato  
lacquered  
laqué  
lackiert  
lacado

|  |            |                    |
|--|------------|--------------------|
|  | <b>Q05</b> | bianco<br>white    |
|  | <b>Q16</b> | seta<br>silk       |
|  | <b>Q17</b> | corda<br>ecru      |
|  | <b>Q20</b> | ghisa<br>cast-iron |

|  |            |                         |
|--|------------|-------------------------|
|  | <b>Q14</b> | antracite<br>anthracite |
|  | <b>Q04</b> | nero<br>black           |
|  | <b>Q21</b> | bronzo<br>bronze        |

essenze  
woods  
bois  
Holzes  
maderas

|  |            |                |
|--|------------|----------------|
|  | <b>Y36</b> | rovere<br>oak  |
|  | <b>Y34</b> | noce<br>walnut |

|  |            |                                 |
|--|------------|---------------------------------|
|  | <b>Y37</b> | rovere affumicato<br>smoked oak |
|  | <b>Y38</b> | rovere nero<br>black oak        |

**contenitori / cabinets / modules de rangement / Behälter / contenedores**

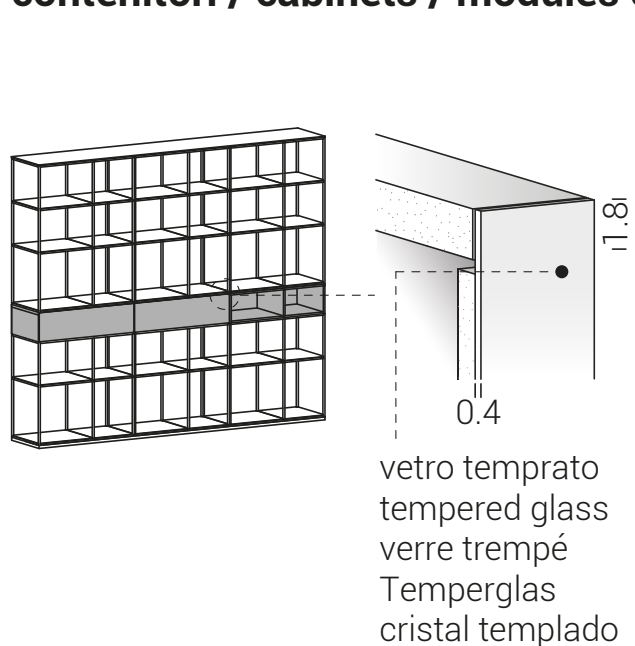

laccato  
lacquered  
laqué  
lackiert  
lacado

|  |            |                    |
|--|------------|--------------------|
|  | <b>Q05</b> | bianco<br>white    |
|  | <b>Q16</b> | seta<br>silk       |
|  | <b>Q17</b> | corda<br>ecru      |
|  | <b>Q20</b> | ghisa<br>cast-iron |

|  |            |                         |
|--|------------|-------------------------|
|  | <b>Q14</b> | antracite<br>anthracite |
|  | <b>Q04</b> | nero<br>black           |
|  | <b>Q21</b> | bronzo<br>bronze        |

essenze  
woods  
bois  
Holzes  
maderas

|  |            |                                 |
|--|------------|---------------------------------|
|  | <b>Y37</b> | rovere affumicato<br>smoked oak |
|  | <b>Y38</b> | rovere nero<br>black oak        |

|  |            |                                 |
|--|------------|---------------------------------|
|  | <b>Y37</b> | rovere affumicato<br>smoked oak |
|  | <b>Y38</b> | rovere nero<br>black oak        |

**moduli interni / internal modules / modules internes / interne Module / módulos internos**

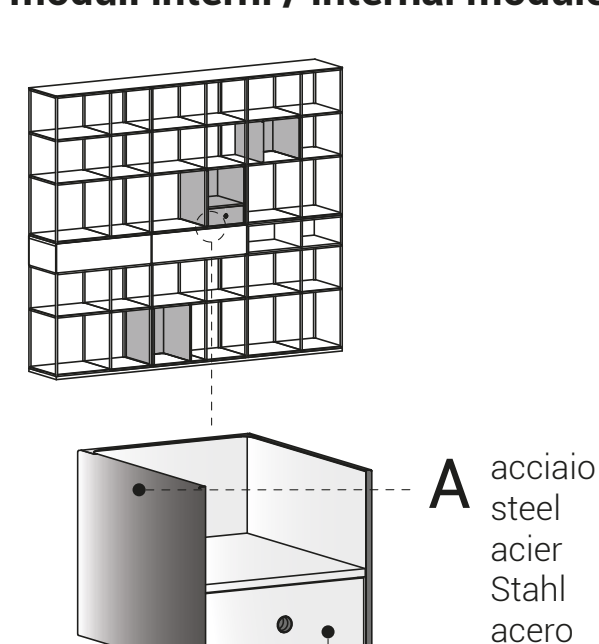

**A** verniciato  
painted  
peint  
lackierter  
pintado

|  |            |                    |
|--|------------|--------------------|
|  | <b>C12</b> | bianco<br>white    |
|  | <b>C21</b> | seta<br>silk       |
|  | <b>C23</b> | corda<br>ecru      |
|  | <b>C30</b> | ghisa<br>cast-iron |

|  |            |                         |
|--|------------|-------------------------|
|  | <b>C14</b> | antracite<br>anthracite |
|  | <b>C08</b> | nero<br>black           |
|  | <b>C29</b> | bronzo<br>bronze        |

**B** laccato  
lacquered  
laqué  
lackiert  
lacado

|  |            |                    |
|--|------------|--------------------|
|  | <b>Q05</b> | bianco<br>white    |
|  | <b>Q16</b> | seta<br>silk       |
|  | <b>Q17</b> | corda<br>ecru      |
|  | <b>Q20</b> | ghisa<br>cast-iron |

|  |            |                         |
|--|------------|-------------------------|
|  | <b>Q14</b> | antracite<br>anthracite |
|  | <b>Q04</b> | nero<br>black           |
|  | <b>Q21</b> | bronzo<br>bronze        |

essenze  
woods  
bois  
Holzes  
maderas

|  |            |                                 |
|--|------------|---------------------------------|
|  | <b>Y37</b> | rovere affumicato<br>smoked oak |
|  | <b>Y38</b> | rovere nero<br>black oak        |

|  |            |                                 |
|--|------------|---------------------------------|
|  | <b>Y37</b> | rovere affumicato<br>smoked oak |
|  | <b>Y38</b> | rovere nero<br>black oak        |

**ripiani / shelves / étagères / Böden / estantes**

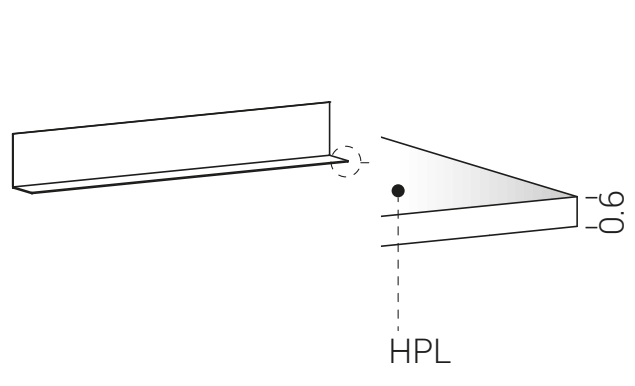

laccato  
lacquered  
laqué  
lackiert  
lacado

|  |            |                    |
|--|------------|--------------------|
|  | <b>Q05</b> | bianco<br>white    |
|  | <b>Q16</b> | seta<br>silk       |
|  | <b>Q17</b> | corda<br>ecru      |
|  | <b>Q20</b> | ghisa<br>cast-iron |

|  |            |                         |
|--|------------|-------------------------|
|  | <b>Q14</b> | antracite<br>anthracite |
|  | <b>Q04</b> | nero<br>black           |
|  | <b>Q21</b> | bronzo<br>bronze        |

essenze  
woods  
bois  
Holzes  
maderas

|  |            |                |
|--|------------|----------------|
|  | <b>Y36</b> | rovere<br>oak  |
|  | <b>Y34</b> | noce<br>walnut |

|  |            |                                 |
|--|------------|---------------------------------|
|  | <b>Y37</b> | rovere affumicato<br>smoked oak |
|  | <b>Y38</b> | rovere nero<br>black oak        |

**base / base / base / Basis / base**

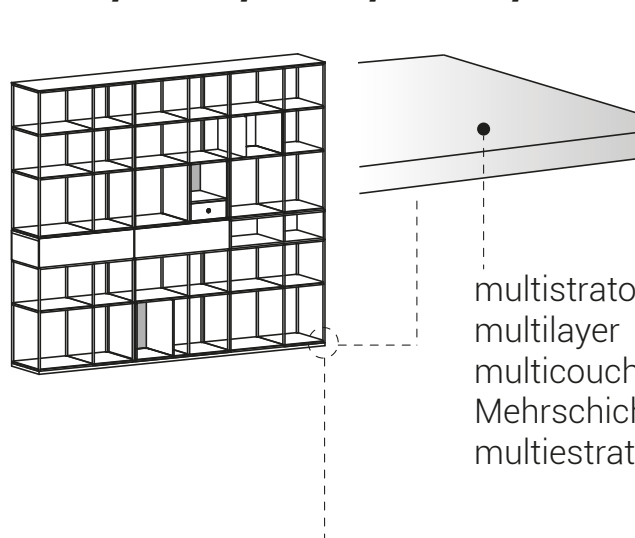

laccato  
lacquered  
laqué  
lackiert  
lacado

|  |            |                    |
|--|------------|--------------------|
|  | <b>Q05</b> | bianco<br>white    |
|  | <b>Q16</b> | seta<br>silk       |
|  | <b>Q17</b> | corda<br>ecru      |
|  | <b>Q20</b> | ghisa<br>cast-iron |

|  |            |                         |
|--|------------|-------------------------|
|  | <b>Q14</b> | antracite<br>anthracite |
|  | <b>Q04</b> | nero<br>black           |
|  | <b>Q21</b> | bronzo<br>bronze        |

verniciato  
painted  
peint  
lackierter  
pintado

|  |            |                    |
|--|------------|--------------------|
|  | <b>C12</b> | bianco<br>white    |
|  | <b>C21</b> | seta<br>silk       |
|  | <b>C23</b> | corda<br>ecru      |
|  | <b>C30</b> | ghisa<br>cast-iron |

|  |            |                         |
|--|------------|-------------------------|
|  | <b>C14</b> | antracite<br>anthracite |
|  | <b>C08</b> | nero<br>black           |
|  | <b>C29</b> | bronzo<br>bronze        |

**piano / top / plateau / platte / sobre**

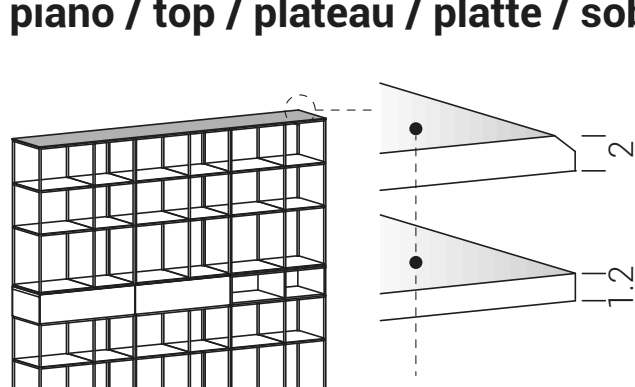

marmo  
marble  
marbre  
Marmor  
mármol

|  |            |                                 |
|--|------------|---------------------------------|
|  | <b>Z01</b> | bianco Carrara<br>white Carrara |
|  | <b>Z02</b> | nero Marquiña<br>black Marquiña |

HPL

|  |            |                              |
|--|------------|------------------------------|
|  | <b>L03</b> | bianco<br>white              |
|  | <b>L08</b> | grigio Londra<br>London grey |
|  | <b>L06</b> | nero<br>black                |

HPL + legno  
wood  
bois  
Holz  
madera

|  |            |                |
|--|------------|----------------|
|  | <b>Y36</b> | rovere<br>oak  |
|  | <b>Y34</b> | noce<br>walnut |

|  |            |                                 |
|--|------------|---------------------------------|
|  | <b>Y37</b> | rovere affumicato<br>smoked oak |
|  | <b>Y38</b> | rovere nero<br>black oak        |

HPL + metallo  
metal  
métal  
Metall  
metal

|  |            |                            |
|--|------------|----------------------------|
|  | <b>C31</b> | ottone<br>brass            |
|  | <b>C32</b> | ottone scuro<br>dark brass |

|  |            |                         |
|--|------------|-------------------------|
|  | <b>C35</b> | inox<br>inox            |
|  | <b>C36</b> | inox scuro<br>dark inox |

HPL + ecotouch

|  |            |                   |
|--|------------|-------------------|
|  | <b>N01</b> | sabbia<br>sand    |
|  | <b>N02</b> | basalto<br>basalt |

HPL + cemento  
concrete  
ciment  
zement  
cemento

|  |            |                                  |
|--|------------|----------------------------------|
|  | <b>D01</b> | bianco calce<br>lime white       |
|  | <b>D02</b> | grigio Portland<br>Portland grey |

laccato  
lacquered  
laqué  
lackiert  
lacado

|  |            |                    |
|--|------------|--------------------|
|  | <b>Q05</b> | bianco<br>white    |
|  | <b>Q16</b> | seta<br>silk       |
|  | <b>Q17</b> | corda<br>ecru      |
|  | <b>Q20</b> | ghisa<br>cast-iron |

|  |            |                         |
|--|------------|-------------------------|
|  | <b>Q14</b> | antracite<br>anthracite |
|  | <b>Q04</b> | nero<br>black           |
|  | <b>Q21</b> | bronzo<br>bronze        |

HPL + pietra naturale  
natural stone  
pierre naturelle  
Naturstein  
piedra natural

|  |            |                             |
|--|------------|-----------------------------|
|  | <b>P01</b> | grigio cenere<br>ash grey   |
|  | <b>P02</b> | nero ardesia<br>slate black |









## atelier AT02

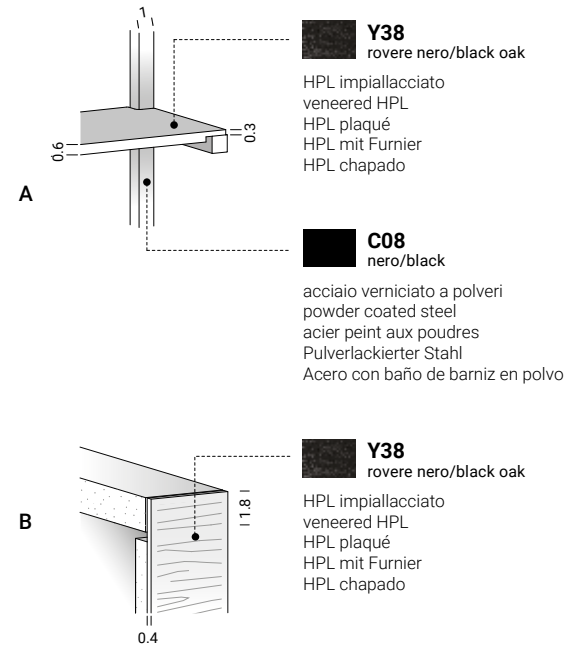
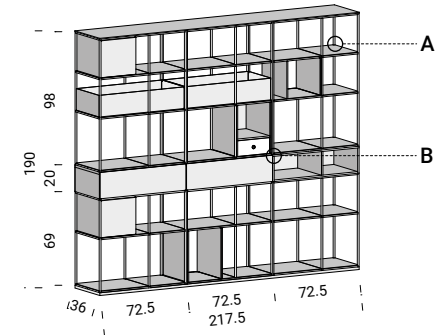

collection info  
pg. 08





## atelier

AT03

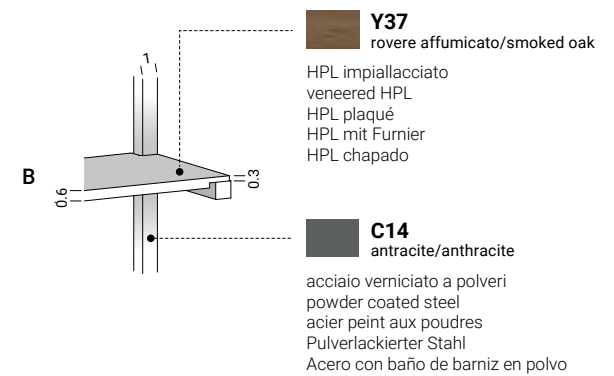
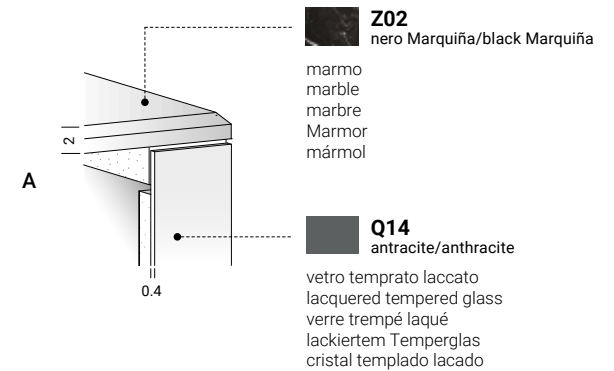
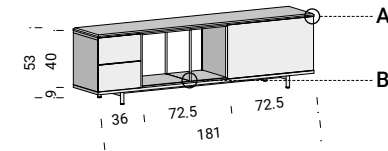

collection info  
pg. 08







## atelier AT01

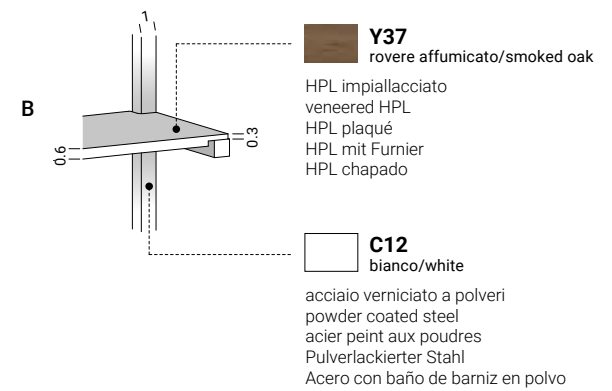
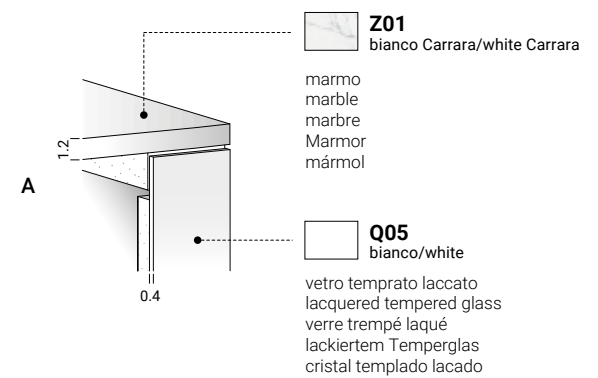
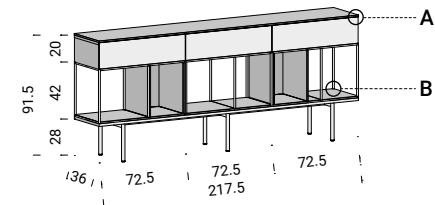

collection info  
pg. 08







## atelier AT04

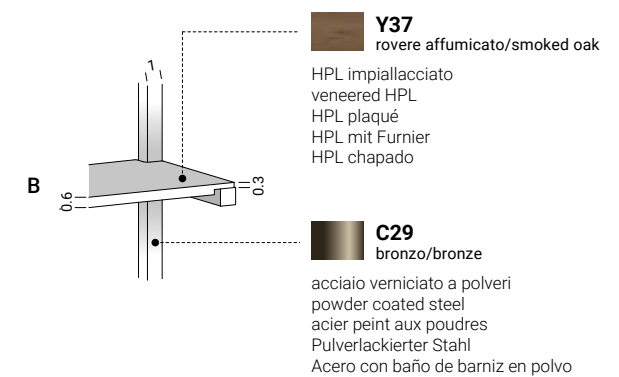
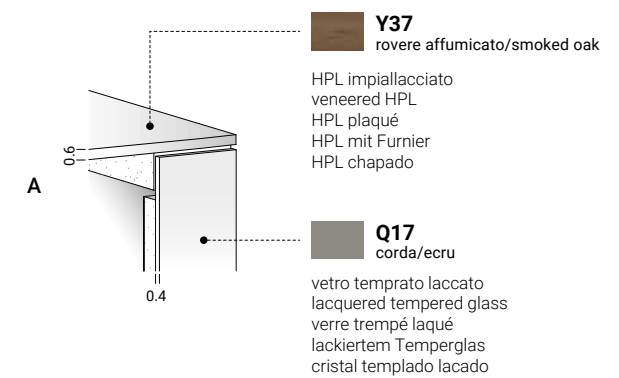
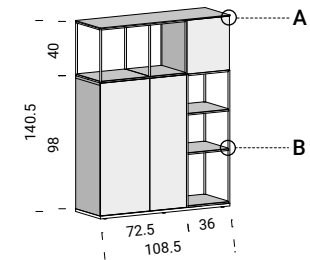

collection info  
pg. 08







**atelier**  
AT06

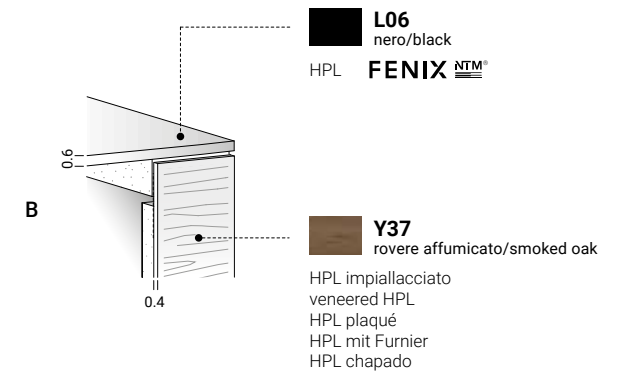
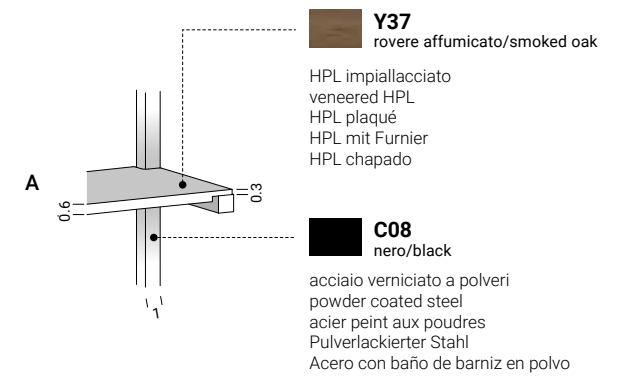
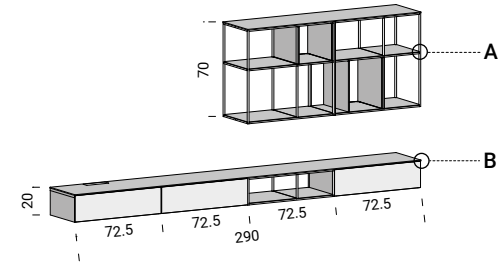

collection info  
pg. 08





## atelier AT05

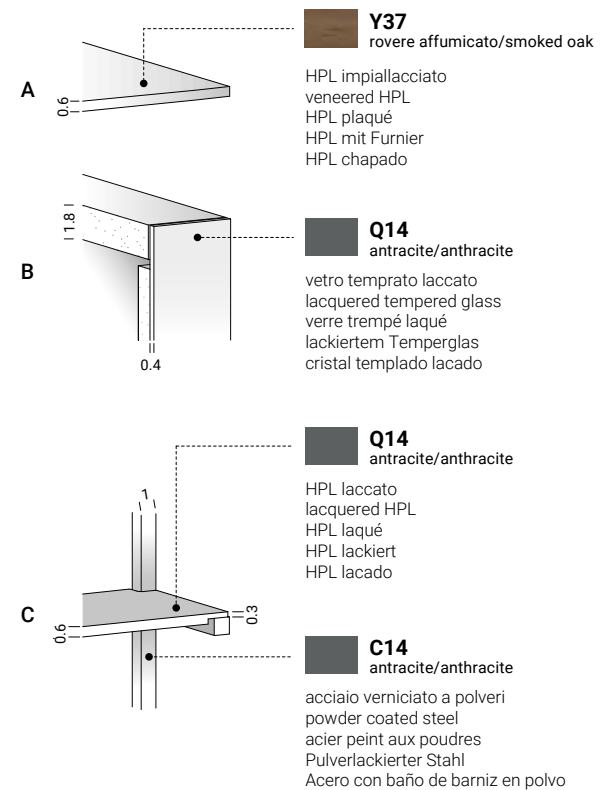
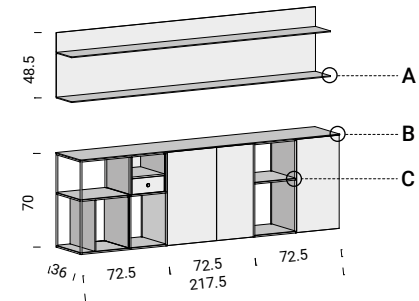

collection info  
pg. 08





## atelier AT07

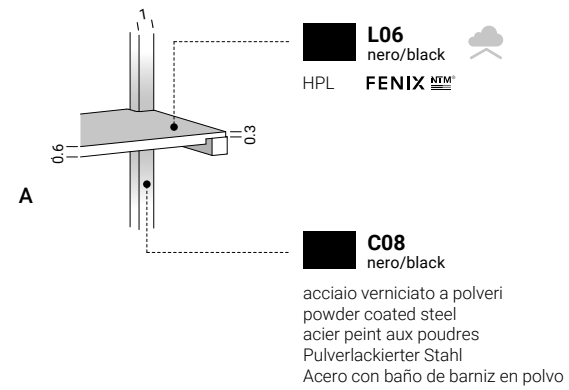
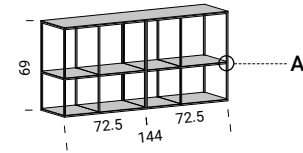

collection info  
pg. 08



## atelier

AT08

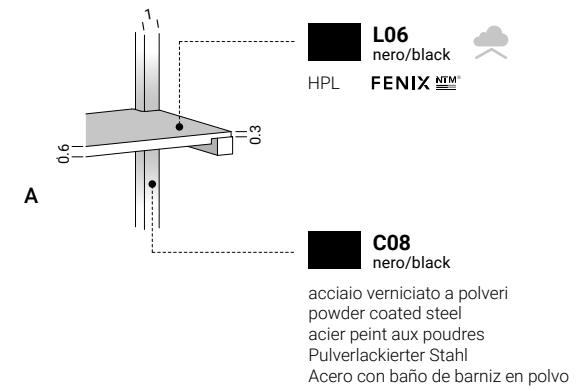
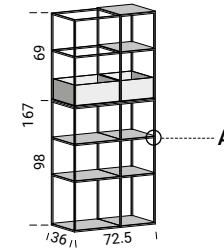

collection info  
pg. 08

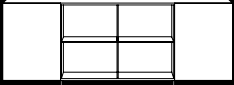

# monolith

**La scocca in alluminio estruso che costituisce l'ossatura portante di monolith, consente grande rigidità strutturale e una libera configurazione delle partizioni interne. Tale sistema costruttivo forma un insieme molto semplice da assemblare e riconfigurare, evitando di raddoppiare gli spessori dei fianchi al suo interno.**

The frame in extruded aluminium forming the support structure of Monolith gives an extremely firm structure with free configuration of the inner partitions. This composition system forms a very simple set to assemble and re-configure, without doubling the thicknesses of its inner sides.

Le châssis en aluminium extrudé qui constitue l'ossature portante de monolith, permet une grande rigidité structurelle et une libre configuration des divisions internes. Ce système de construction forme un ensemble très simple à assembler et reconfigurer, en évitant de doubler les épaisseurs des côtés à l'intérieur.

Der Aufbau aus extrudiertem Aluminium, der das tragenden Gerüst des monolith darstellt, bietet eine bedeutende, strukturelle Steifheit und eine freie Konfigurierung der Innenaufteilung. Dieses Konstruktionssystem bildet eine Einheit, die einfach zusammenzubauen und neu zu gestalten ist, wobei die Verdoppelung der Stärke der Seiten im Innenbereich vermieden wird.

El bastidor de aluminio extruido que constituye el armazón de soporte de Monolith permite una gran resistencia estructural y una libre configuración de las particiones interiores. Este sistema de construcción forma un conjunto muy fácil de montar y reconfigurar, evitando duplicar el espesor de los laterales en su interior.





## materiali / materials



alluminio  
aluminium  
Aluminium  
aluminio



vetro  
glass  
verre  
Glas  
cristal



MDF  
DM

Le materie prime che costituiscono il sistema monolith derivano da un processo di riutilizzo e sono a loro volta riciclabili.

The primary materials used in the system monolith are sourced from a reuse process, and are in turn recyclable.

Les matières premières qui composent le système monolith dérivent d'un processus de réutilisation et sont à leur tour recyclables.

Die Rohstoffe für das System monolith entstammen einem Wiederverwertungsprozess und sind Ihrerseits wiederum recyclebar.

Las materias primas que constituyen el sistema monolith proceden de un proceso de reutilización y son, a su vez, reciclables.



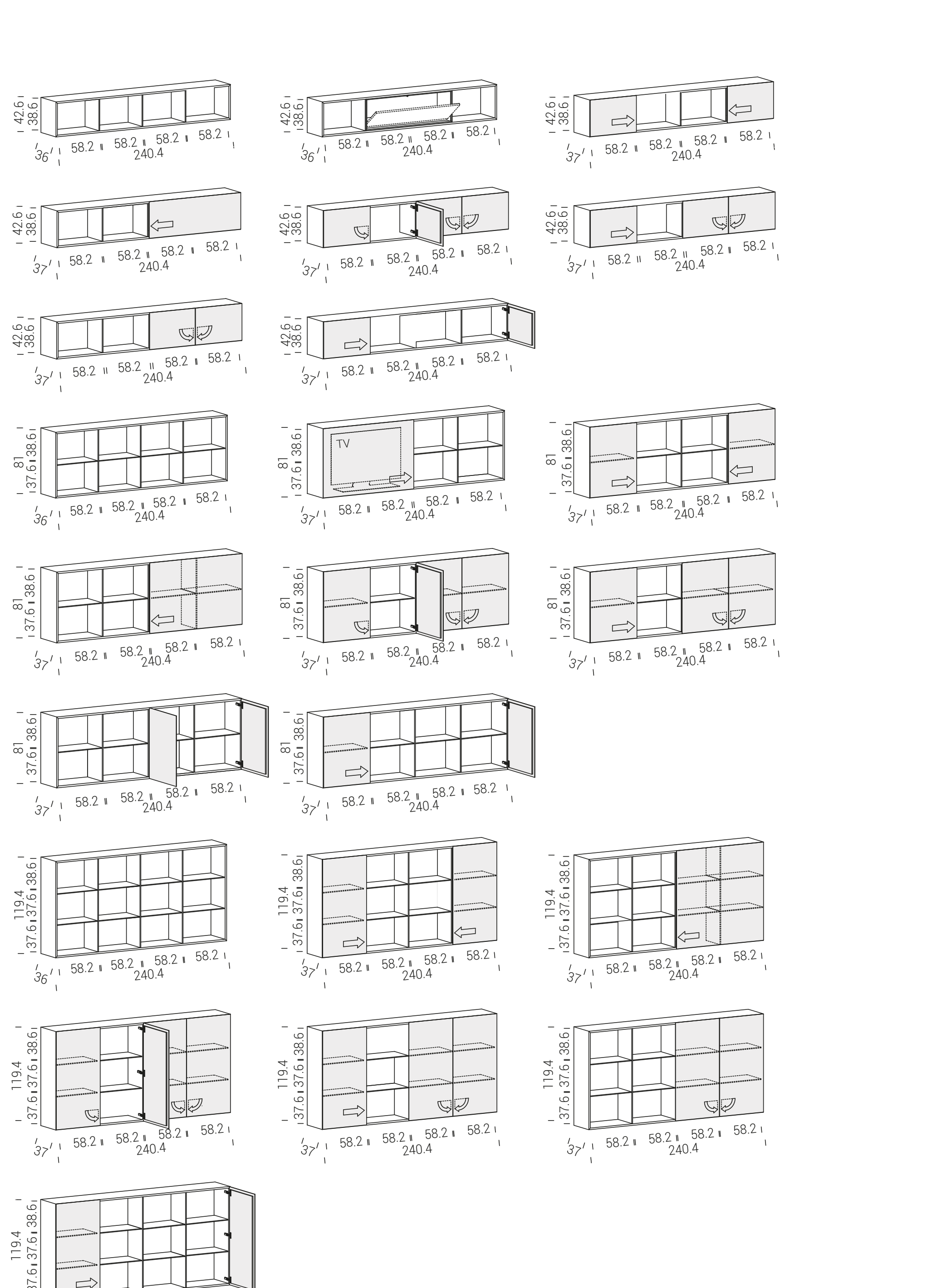
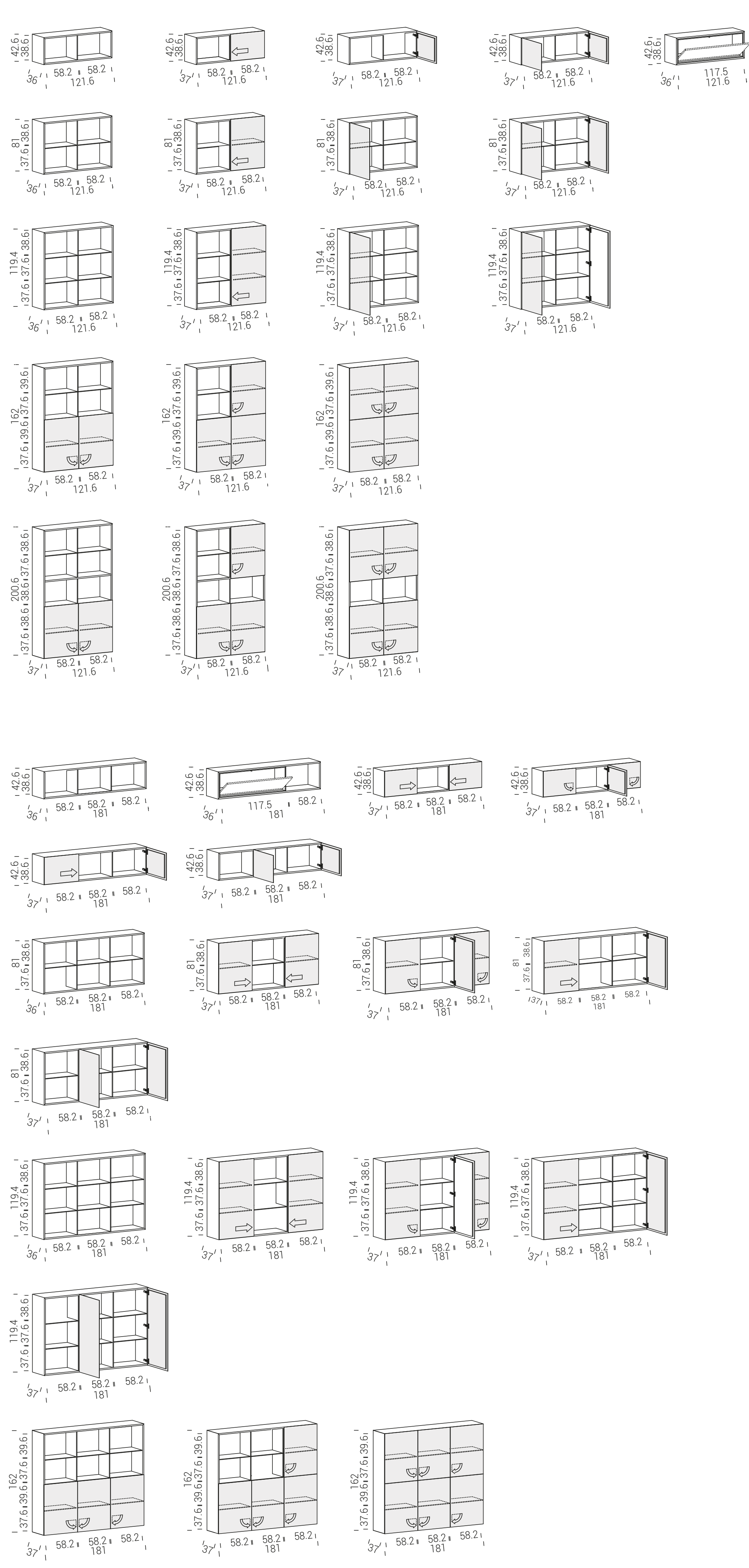

**accessori / accessories / accessoires / Zubehör / accesorios**

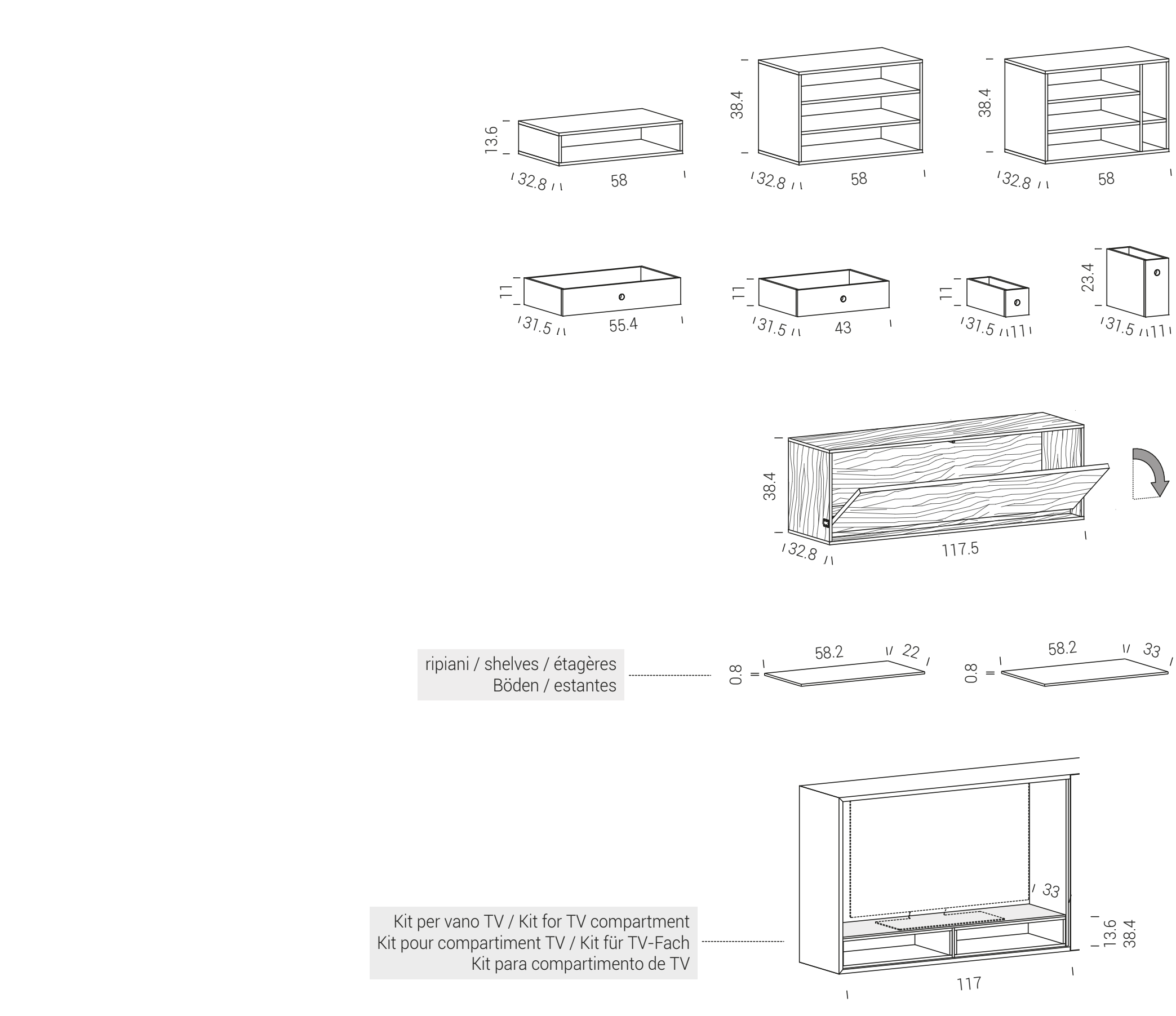

**basi / bases / bases / Basis / bases**

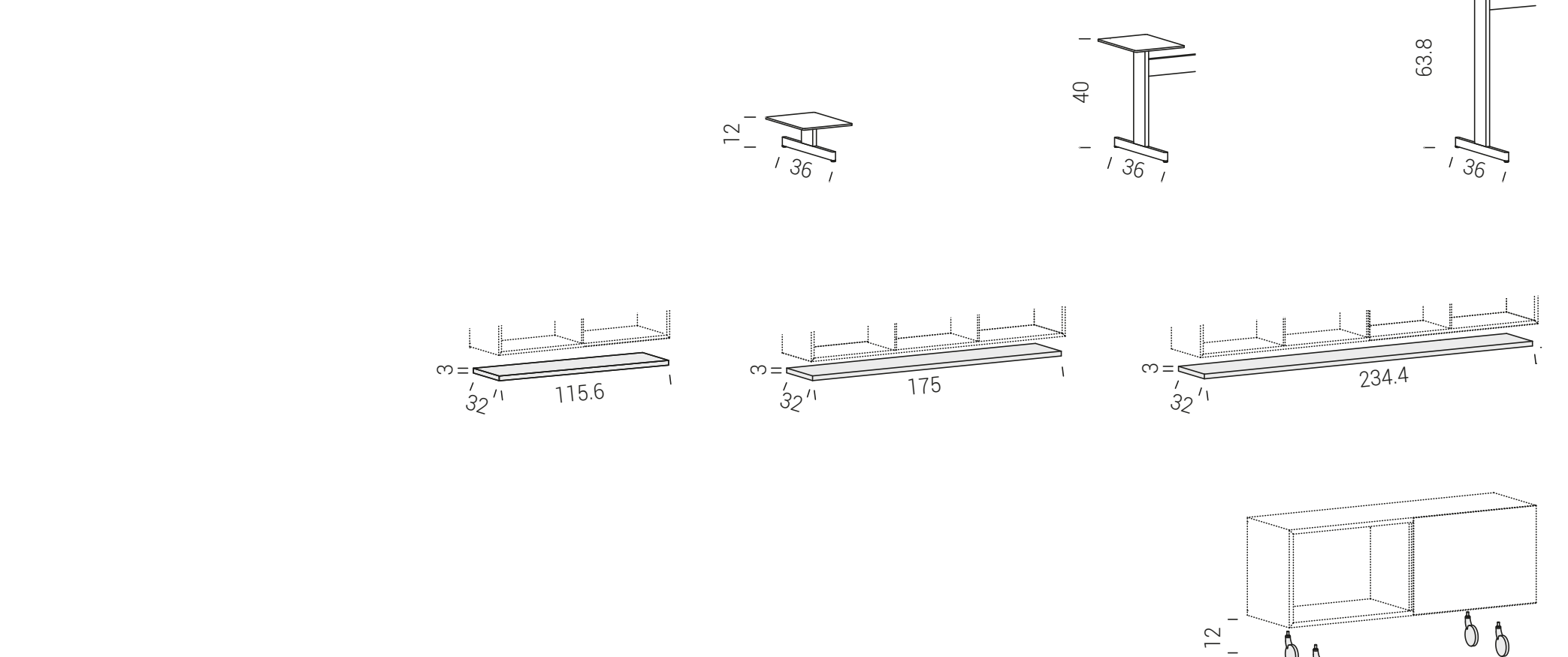

**piano / top / plateau / platte / sobre**







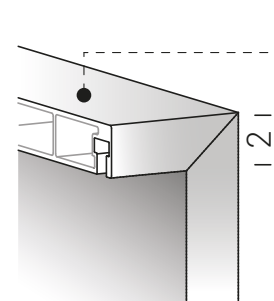
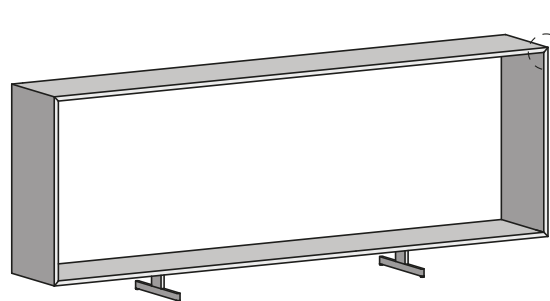

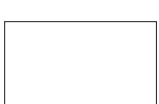

**scocche / shells / cadres / Gehäuse / estructuras**





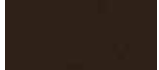

alluminio verniciato  
painted aluminium  
aluminium peint  
lackierter Aluminium  
aluminio pintado

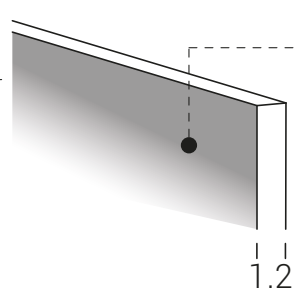
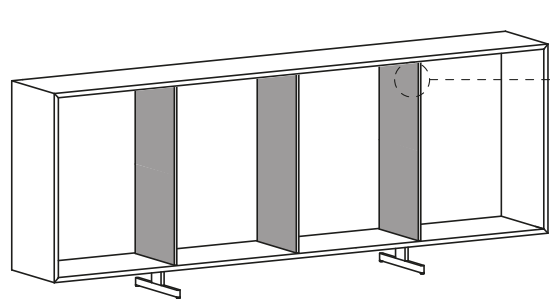
-  **C12** bianco white
-  **C21** seta silk
-  **C23** corda ecru
-  **C30** ghisa cast-iron
-  **C14** antracite anthracite
-  **C08** nero black
-  **C29** bronzo bronze

**fianchi interni / inner sides / côtés internes / Innenseiten / paredes interiores**

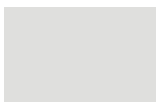

MDF laccato  
lacquered MDF  
MDF laqué  
lackiertem MDF  
DM lacado

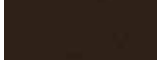
-  **Q05** bianco white
-  **Q16** seta silk
-  **Q17** corda ecru
-  **Q20** ghisa cast-iron
-  **Q14** antracite anthracite
-  **Q04** nero black
-  **Q21** bronzo bronze

**ripiani interni / inner shelving / étagères internes / Innenböden / estantes interiores**

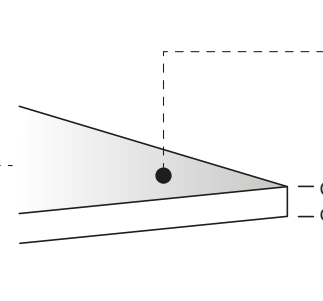
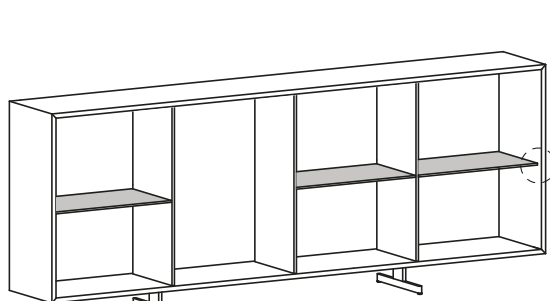

vetro laccato  
lacquered glass  
verre laqué  
lackiertem Glas  
cristal lacado

-  **V01** bianco white
-  **V15** seta silk
-  **V16** corda ecru
-  **V23** ghisa cast-iron
-  **V12** antracite anthracite
-  **V02** nero black
-  **V24** bronzo bronze
  
-  **V07** float
-  **V06** fumè smoked glass

**schiene / backs / dos / Rückwände / traseras**

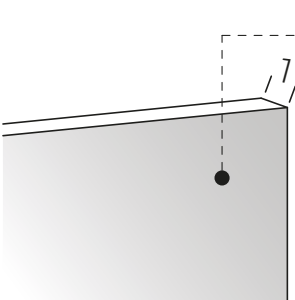
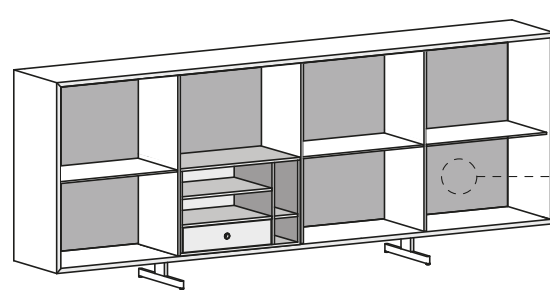





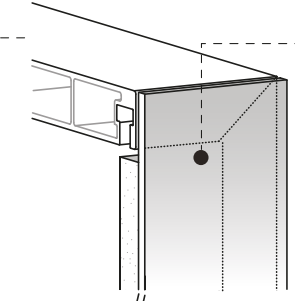
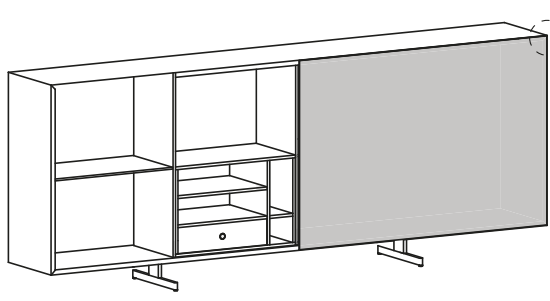

MDF laccato  
lacquered MDF  
MDF laqué  
lackiertem MDF  
DM lacado

-  **Q05** bianco white
-  **Q16** seta silk
-  **Q17** corda ecru
-  **Q20** ghisa cast-iron
-  **Q14** antracite anthracite
-  **Q04** nero black
-  **Q21** bronzo bronze
  
-  **Y36** rovere oak
-  **Y34** noce walnut

**frontali / doors fronts / faces des portes / Fronten der Türen / frontales de las puertas**



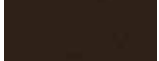

vetro laccato  
lacquered glass  
verre laqué  
lackiertem Glas  
cristal lacado

-  **V01** bianco white
-  **V15** seta silk
-  **V16** corda ecru
-  **V23** ghisa cast-iron
-  **V12** antracite anthracite
-  **V02** nero black
-  **V24** bronzo bronze

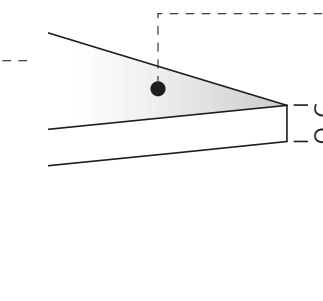
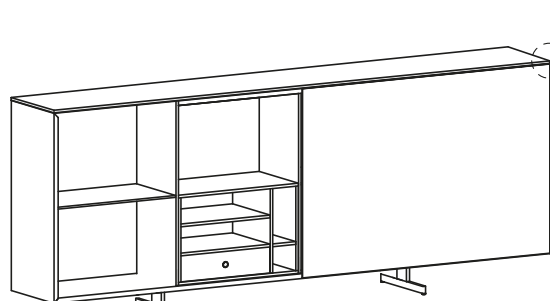
**top**



HPL





-  **L03** bianco white
-  **L08** grigio Londra London grey
-  **L06** nero black

Fenix®

HPL + legno  
wood  
bois  
Holz  
madera

-  **Y36** rovere oak
-  **Y34** noce walnut
-  **Y37** rovere affumicato smoked oak
-  **Y38** rovere nero black oak



HPL + metallo  
metal  
métal  
Metall  
metal

-  **C31** ottone brass
-  **C32** ottone scuro dark brass
-  **C35** inox inox
-  **C36** inox scuro dark inox



HPL + ecotouch

-  **N01** sabbia sand
-  **N02** basalto basalt

HPL + cemento  
concrete  
ciment  
zement  
cemento

-  **D01** bianco calce lime white
-  **D02** grigio Portland Portland grey

HPL + pietra naturale  
natural stone  
pierre naturelle  
Naturstein  
piedra natural

-  **P01** grigio cenere ash grey
-  **P02** nero ardesia slate black

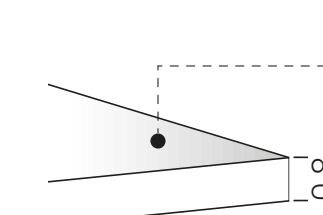





## monolith MN03

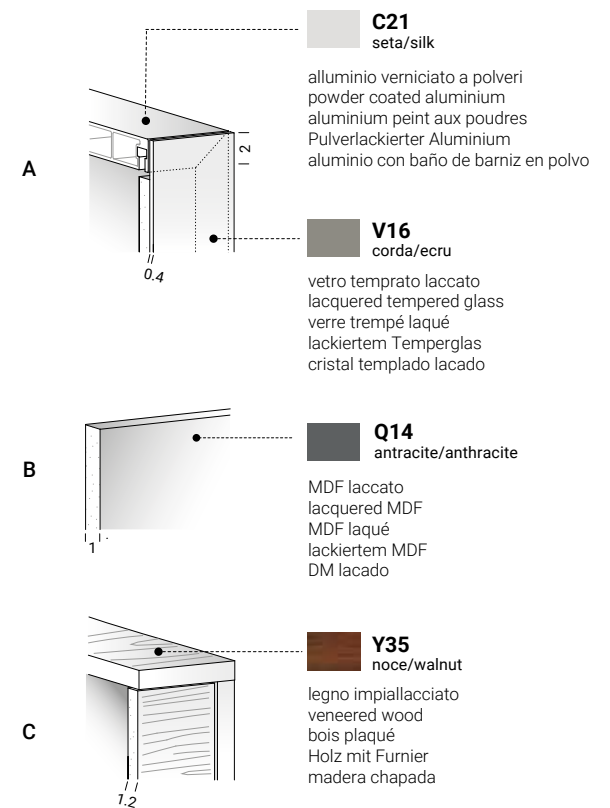
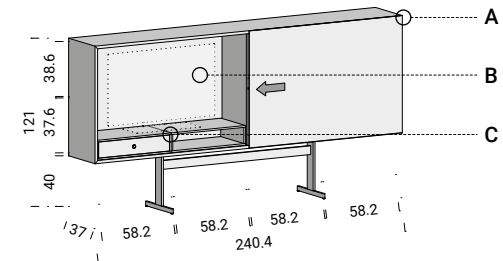

collection info  
pg. 26







# monolith

MN09

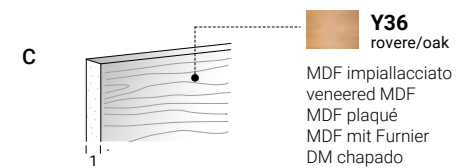
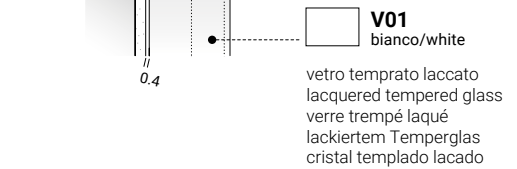
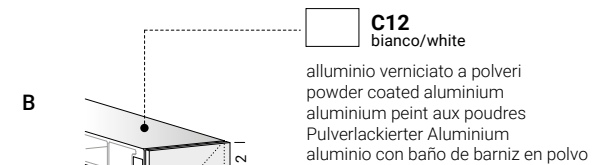
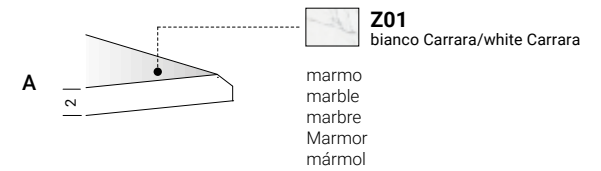
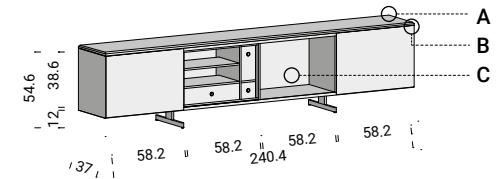

collection info  
pg. 26











## monolith MN08

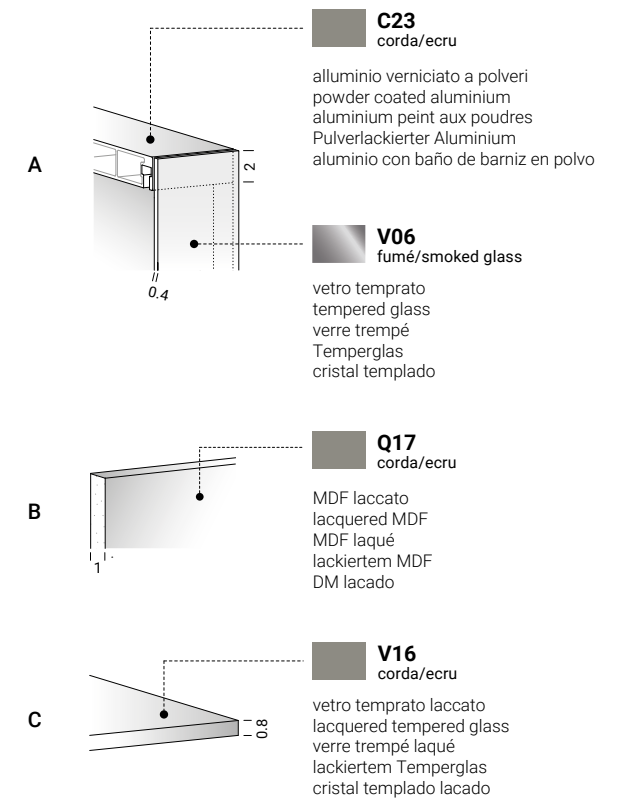
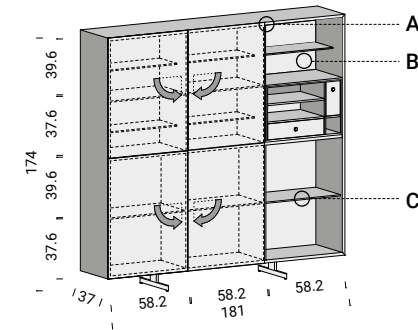

# monolith

MN02C

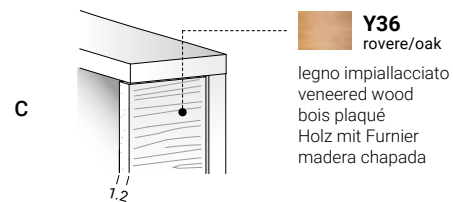
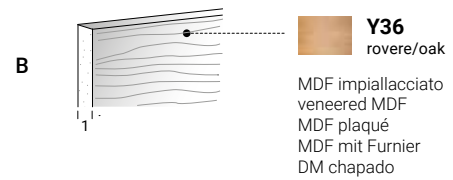
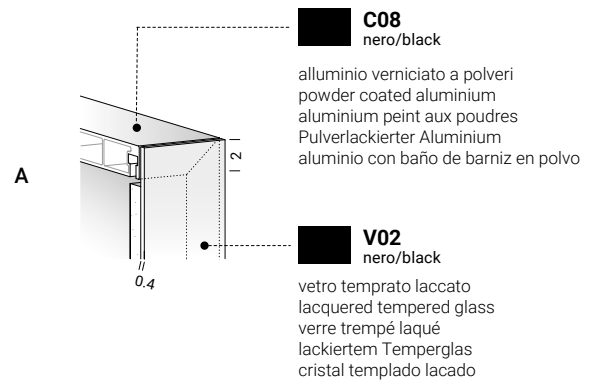
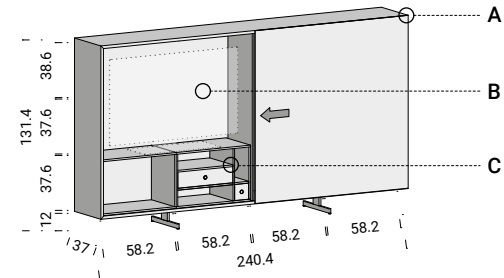

collection info  
pg. 26

# monolith

MN02B

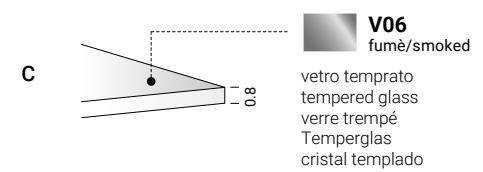
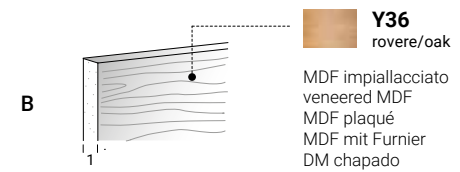
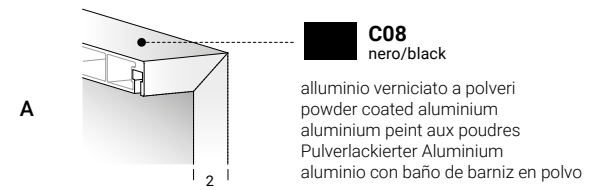
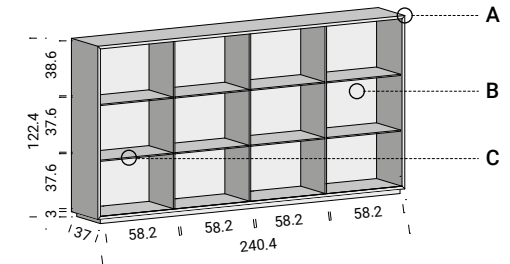

collection info  
pg. 26



## monolith MN06A

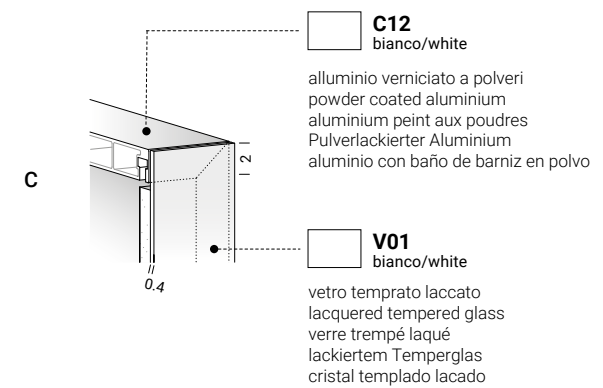
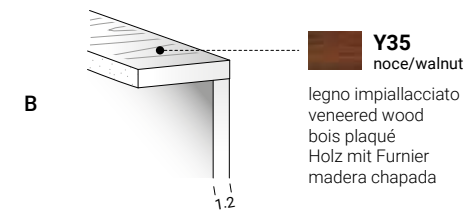
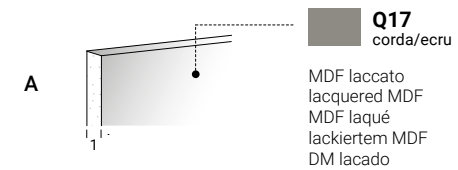
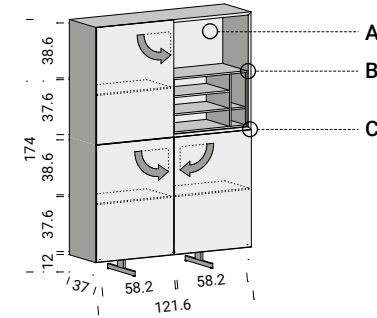

collection info  
pg. 26



## monolith MN06B

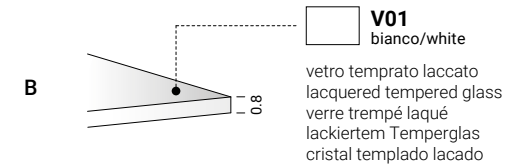
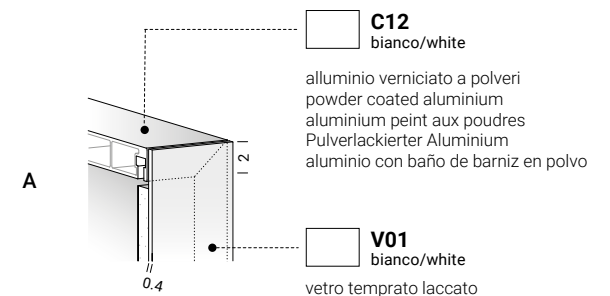
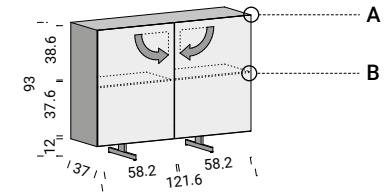

collection info  
pg. 26







# monolith

MN04

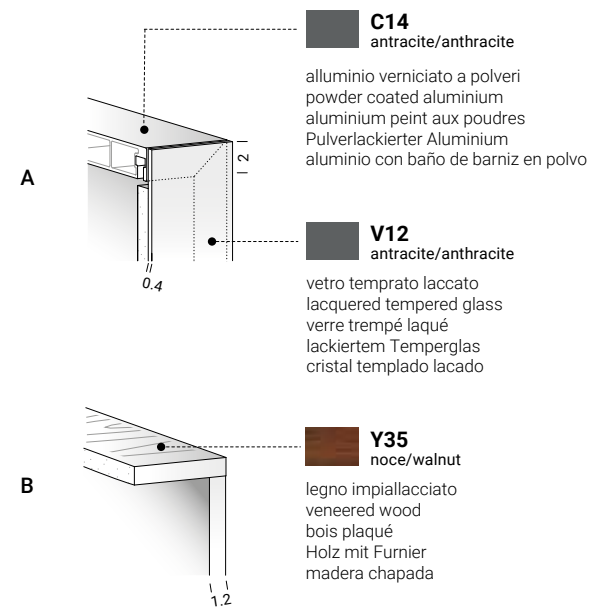
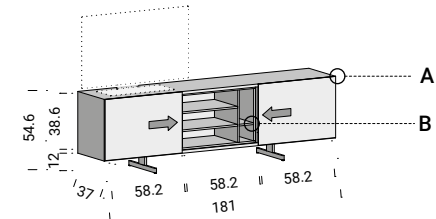

collection info  
pg. 26





# monolith

MN01

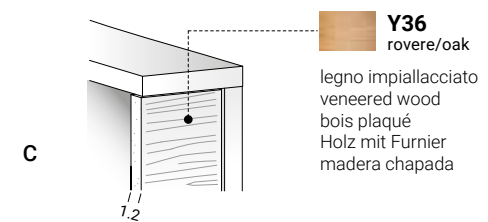
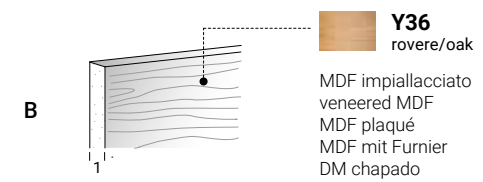
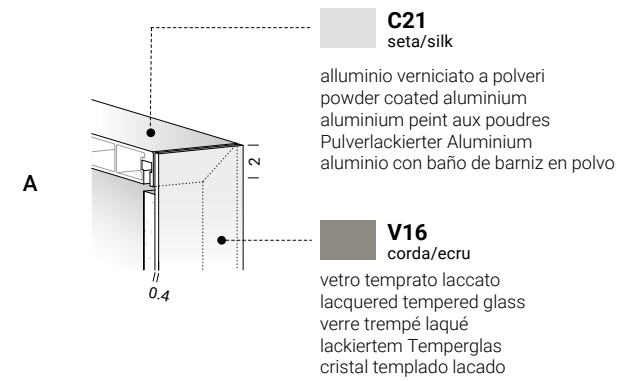
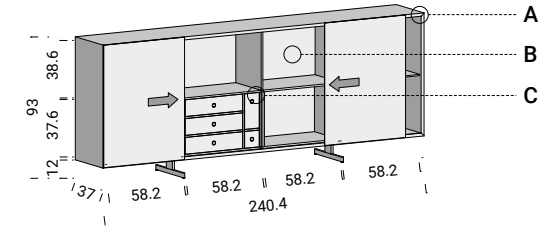

collection info  
pg. 26







**monolith**  
MN02A

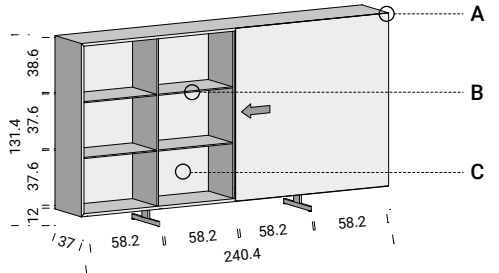

**A**

**C08**  
nero/black

alluminio verniciato a polveri  
powder coated aluminium  
aluminium peint aux poudres  
Pulverlackierter Aluminium  
aluminio con baño de barniz en polvo

**B**

**V02**  
nero/black

vetro temprato laccato  
lacquered tempered glass  
verre trempé laqué  
lackiertem Temperglas  
cristal templado lacado

**C**

**V06**  
fumè/smoked

vetro temprato  
tempered glass  
verre trempé  
Temperglas  
cristal templado

**Y36**  
rovere/oak

MDF impiallacciato  
veneered MDF  
MDF plaqué  
MDF mit Furnier  
DM chapado

collection info  
pg. 26





# monolith

MN05

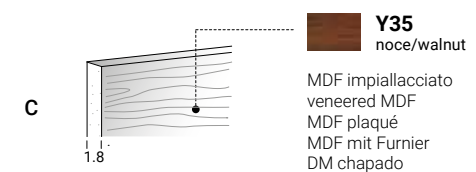
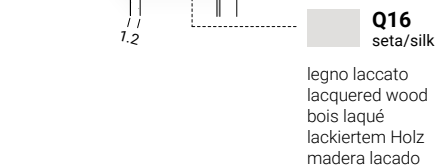
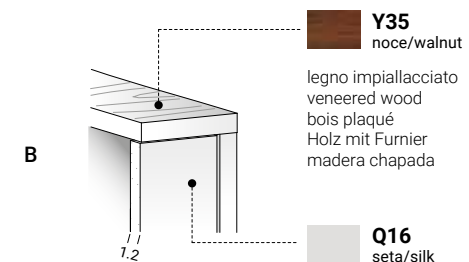
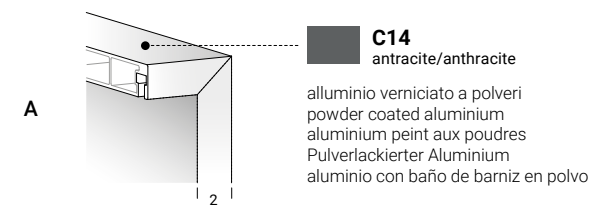
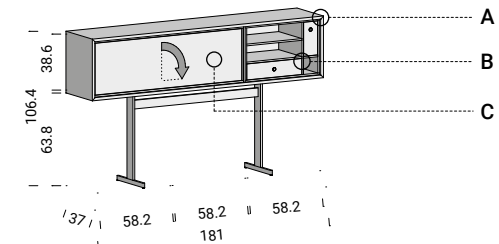

collection info  
pg. 26

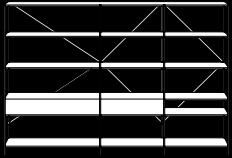

extendo  
patented  
product

# XY

**Il brevetto XY consente di posizionare i ripiani lungo l'asse verticale Y e le coppie di profili portanti lungo l'asse orizzontale X. Il posizionamento in X ed Y avviene in continuo, senza posizioni predefinite. Ciò costituisce un'ossatura portante in grado di essere allestita con schienali, fianchi, ante a ribalta, ante a battente, cassettiere.**

The patented XY system enables you to position the shelves along vertical Y-axis and the pairs of load-bearing profiles along horizontal X-axis. Positioning along X and Y is completely free, without any preset positions. This creates a load-bearing framework that can be completed with backs, sides, tilting or leaf doors, drawer units.

Le brevet XY permet de positionner les étagères le long de l'axe vertical Y et les paires de profilés portants le long de l'axe horizontal X. Le positionnement suivant X et Y s'effectue en continu, sans positions prédéfinies. Ceci réalise une structure portante susceptible d'être équipée de fonds, côtés, portes à rabattant, portes à battant, kits de tiroirs.

Das Patent XY ermöglicht es, die Böden längs der vertikalen Y-Achse und die tragenden Profilpaare längs der horizontalen X-Achse zu positionieren. Dabei kann die Positionierung auf X und Y an jeder Stelle ohne voreingestellte Positionen erfolgen. Auf diese Weise wird eine tragende Struktur gebildet, die mit Rück- und Seitenwänden, Klapp- und Flügeltüren, Schubladenelementen.

La patente XY permite colocar los estantes a lo largo del eje vertical Y y las parejas de perfiles portantes a lo largo del eje horizontal X. La colocación en X e Y se produce en continuo, sin posiciones previamente definidas. Esto forma un armazón portante capaz de albergar dorso, laterales, puertas abatibles, puertas de batiente, cajoneras.



I ripiani e le coppie di profili verticali sono ordinabili al cm. I due elementi sono completi di tappi terminali, piedini regolabili e fissaggi a parete.

The shelves and the pairs of upright profiles can be ordered in any length, in cm. The two elements are supplied complete with end plugs, adjustable feet and wall attachments.

Les étagères et les paires de profilés verticaux sont réalisables sur mesure au cm. Les deux éléments sont équipés d'obturateurs d'extrémité, de pieds réglables et de fixations murales.

Die Böden und die vertikalen Profilpaare können zentimetergenau am laufenden Meter bestellt werden. Die beiden Elemente werden komplett mit Kappen für die Enden, verstellbaren Füßena und Wandbefestigungselementen geliefert.

Los estantes y las parejas de perfiles verticales pueden pedirse al centímetro. Los dos elementos están dotados de tapones terminales, pies regulables y sujeciones para su fijación a la pared.





## XY materials



alluminio  
aluminium  
Aluminium  
aluminio



vetro  
glass  
verre  
Glas  
cristal



MDF  
DM



Le materie prime che costituiscono il sistema XY derivano da un processo di riutilizzo e sono a loro volta riciclabili.

The primary materials used in the system XY are sourced from a reuse process, and are in turn recyclable.

Les matières premières qui composent le système XY dérivent d'un processus de réutilisation et sont à leur tour recyclables.

Die Rohstoffe für das System XY entstammen einem Wiederverwertungsprozess und sind Ihrerseits wiederum recyclebar.

Las materias primas que constituyen el sistema XY proceden de un proceso de reutilización y son, a su vez, reciclables.



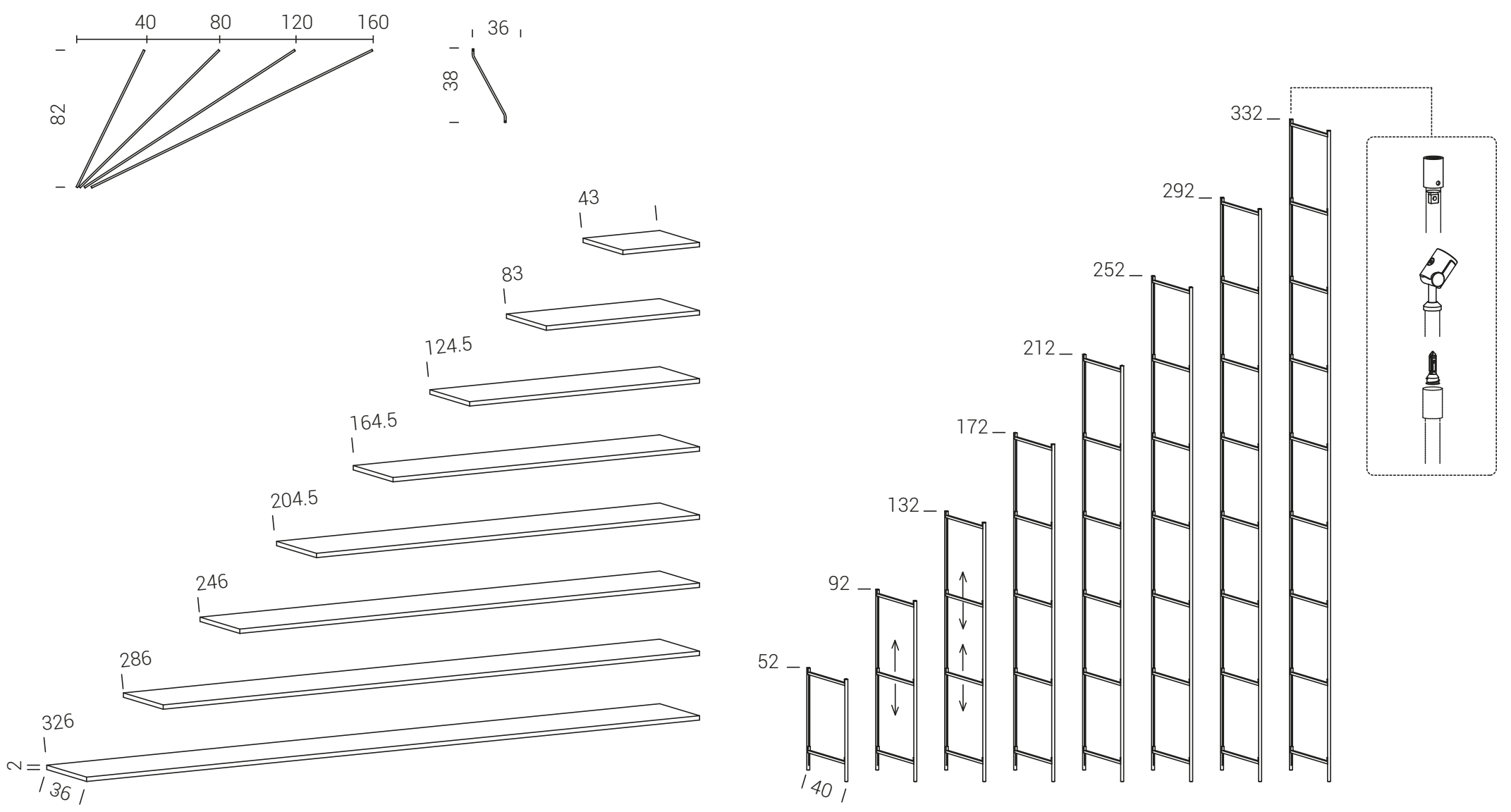

**telaio / structure / châssis / Gestell / bastidor**

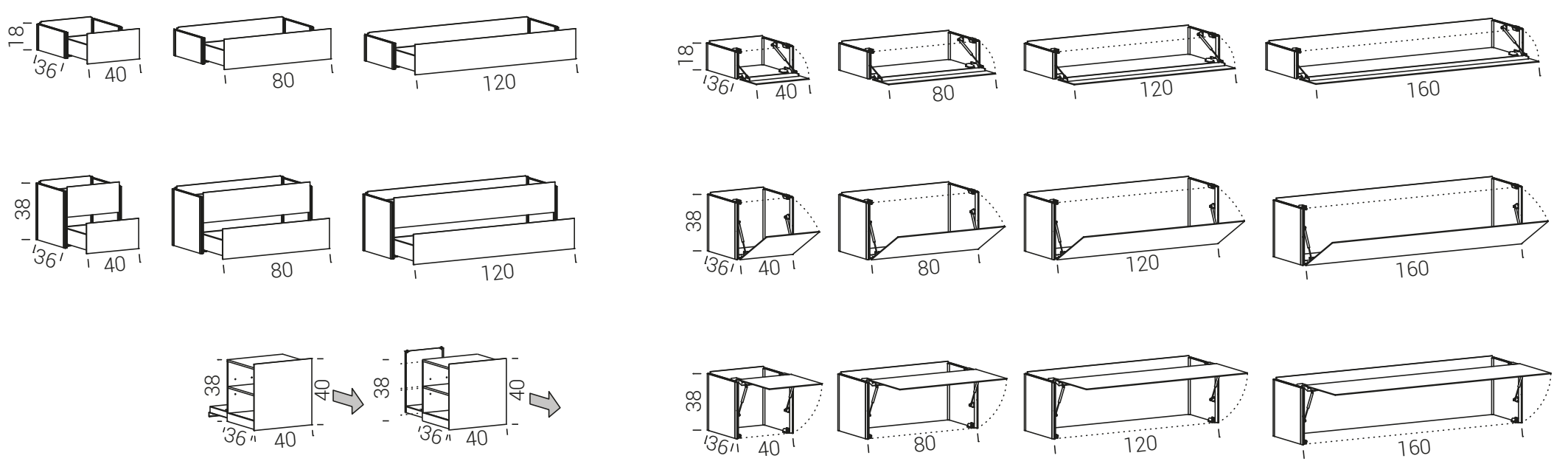

 disponibili riduzioni a misura / tailor-made reduction available / disponibles réductions sur mesure  
Verkleinerung nach Kundenwunsch / disponibles reducciones a medida

**ante ribalta e cassettiere / tilting doors and drawer units / portes à rabattant et kits de tiroirs  
Klapptür und Schubladenelemente / puertas abatibles y cajoneras**



 disponibili riduzioni a misura / tailor-made reduction available / disponibles réductions sur mesure  
Verkleinerung nach Kundenwunsch / disponibles reducciones a medida

**ante battente / leaf doors / portes à battant / Flügeltüren / puertas de batiente**

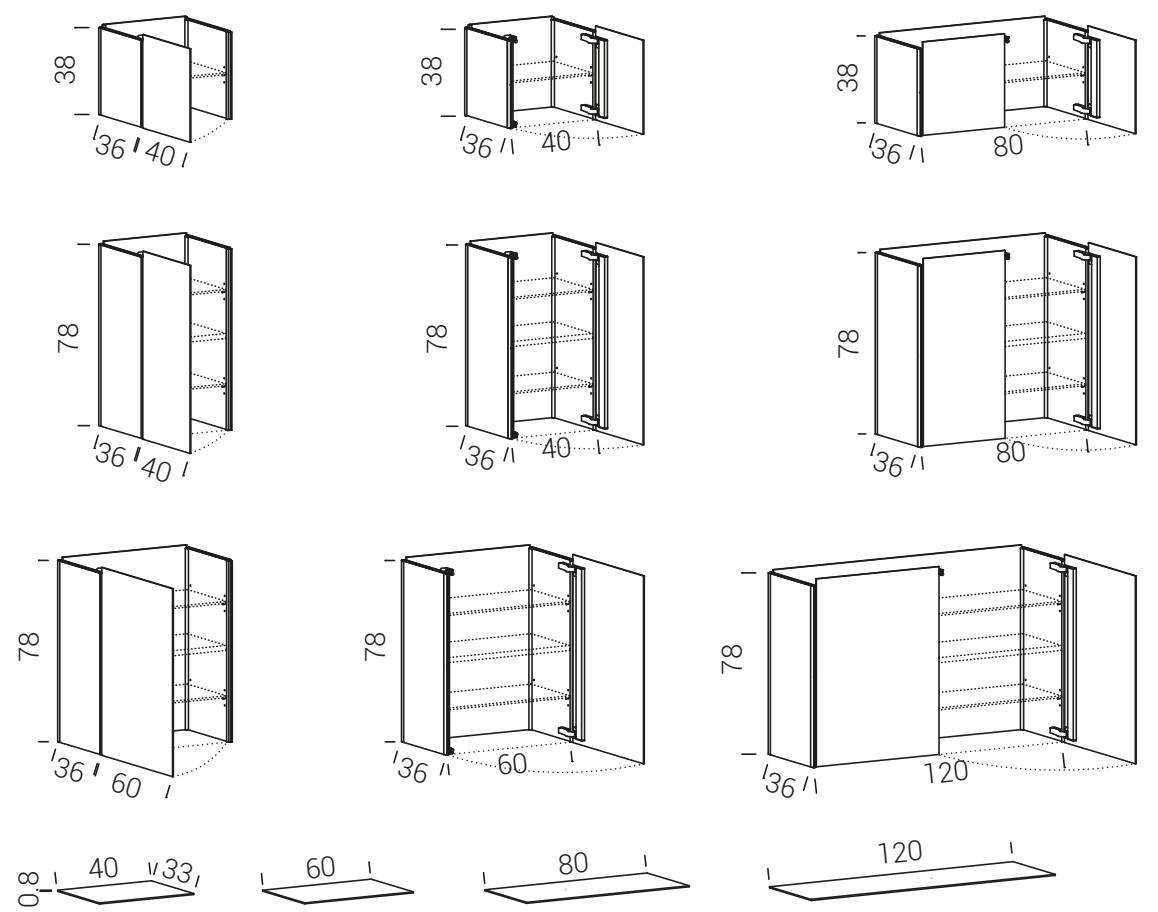

**schiene e fianchi / backs and sides / fonds et côtés / Rückwände und Seitenwände / dorsos y laterales**

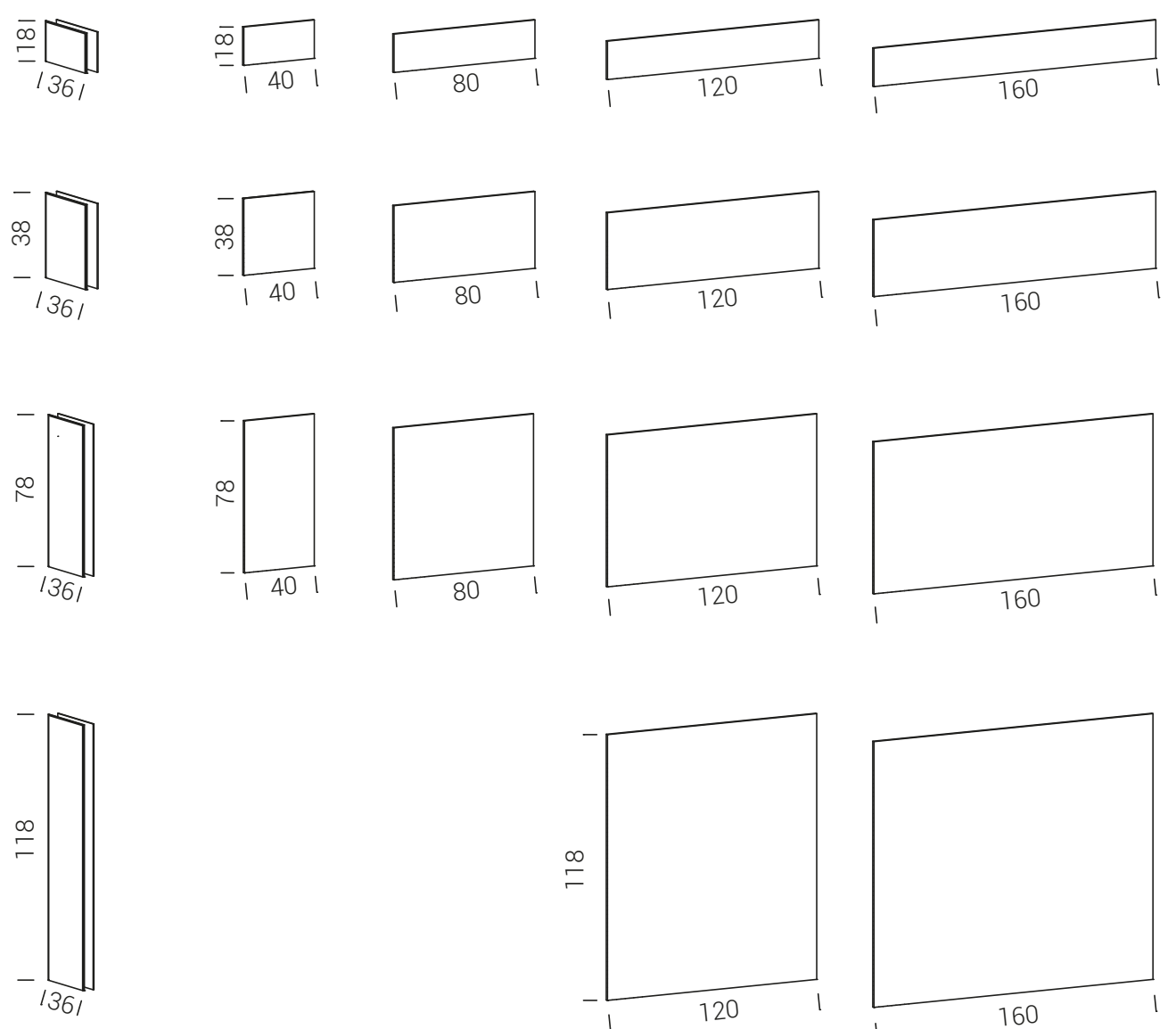

 disponibili riduzioni a misura / tailor-made reduction available / disponibles réductions sur mesure  
Verkleinerung nach Kundenwunsch / disponibles reducciones a medida

**piano / top / plateau / platte / sobre**

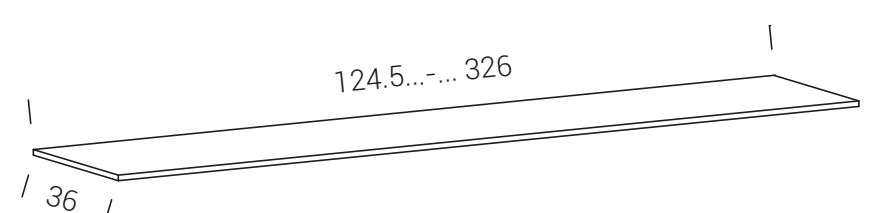

telaio / structure / châssis / Gestell / bastidor

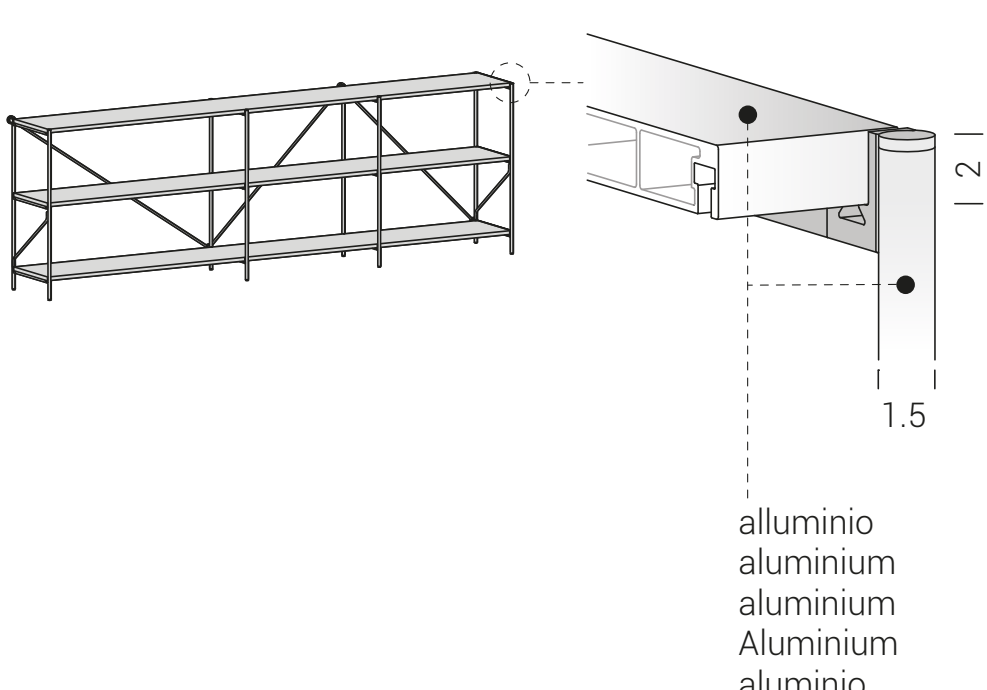

verniciatura a polveri  
powder coating  
peinture en poudres  
Pulverlackierung  
pintura en polvo

|  |                                    |
|--|------------------------------------|
|  | <b>C12</b> bianco<br>white         |
|  | <b>C14</b> antracite<br>anthracite |
|  | <b>C08</b> nero<br>black           |

100 cm => 50 kg

ante ribalta e cassetiere / tilting doors and drawer units / portes à rabattant et kits de tiroirs  
Klapptür und Schubladenelemente / puertas abatibles y cajoneras

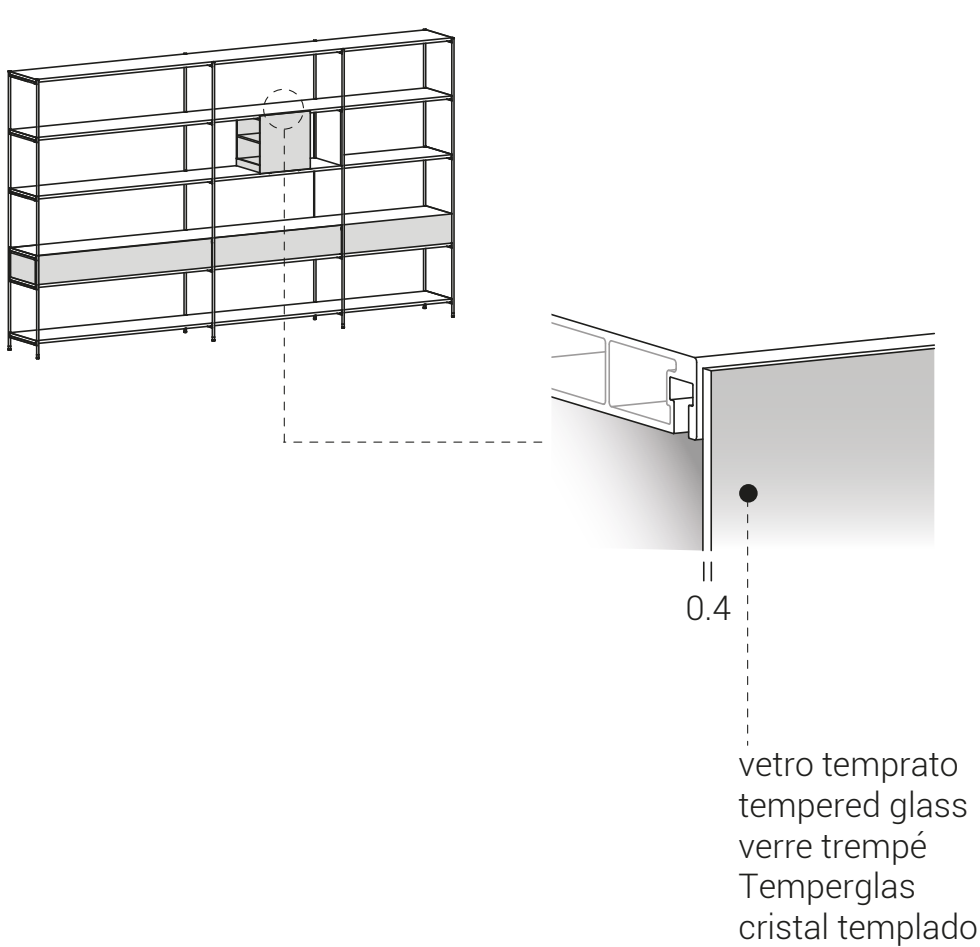

laccato  
lacquered  
laqué  
lackiert  
lacado

|  |                                    |
|--|------------------------------------|
|  | <b>Q05</b> bianco<br>white         |
|  | <b>Q16</b> seta<br>silk            |
|  | <b>Q17</b> corda<br>ecru           |
|  | <b>Q20</b> ghisa<br>cast-iron      |
|  | <b>Q14</b> antracite<br>anthracite |
|  | <b>Q04</b> nero<br>black           |
|  | <b>Q21</b> bronzo<br>bronze        |

ante battente / leaf doors / portes à battant / Flügelüren / puertas de batiente

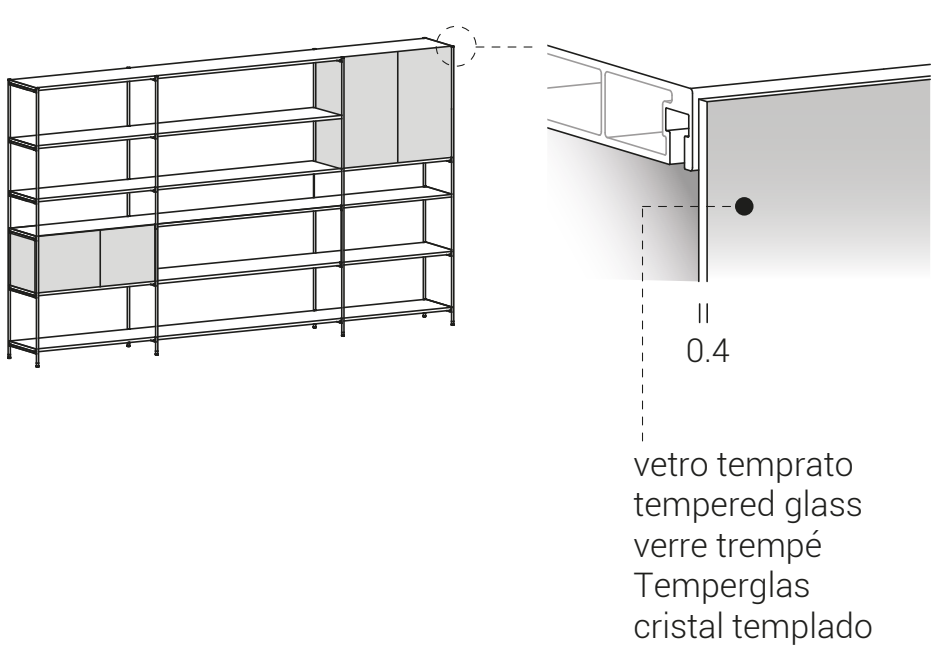

laccato  
lacquered  
laqué  
lackiert  
lacado

|  |                                    |
|--|------------------------------------|
|  | <b>Q05</b> bianco<br>white         |
|  | <b>Q16</b> seta<br>silk            |
|  | <b>Q17</b> corda<br>ecru           |
|  | <b>Q20</b> ghisa<br>cast-iron      |
|  | <b>Q14</b> antracite<br>anthracite |
|  | <b>Q04</b> nero<br>black           |
|  | <b>Q21</b> bronzo<br>bronze        |

schiene e fianchi / backs and sides / fonds et côtés  
Rückwände und Seitenwände / dorsos y laterales

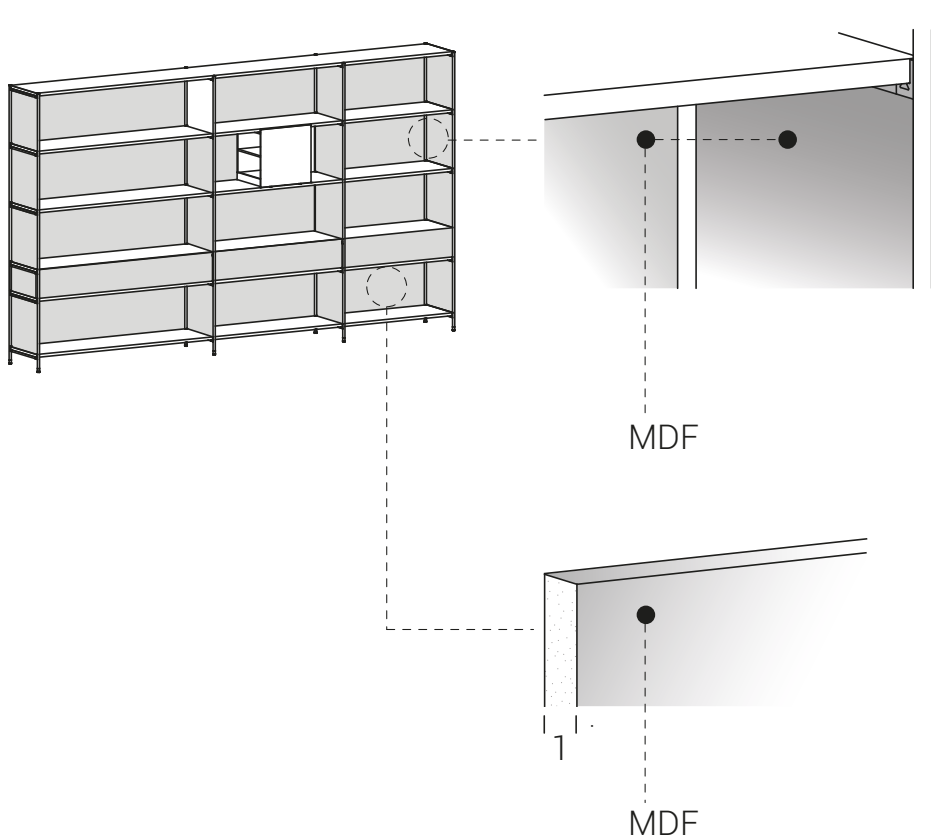

laccato  
lacquered  
laqué  
lackiert  
lacado

|  |                                    |
|--|------------------------------------|
|  | <b>Q05</b> bianco<br>white         |
|  | <b>Q16</b> seta<br>silk            |
|  | <b>Q17</b> corda<br>ecru           |
|  | <b>Q20</b> ghisa<br>cast-iron      |
|  | <b>Q14</b> antracite<br>anthracite |
|  | <b>Q04</b> nero<br>black           |
|  | <b>Q21</b> bronzo<br>bronze        |

essenze  
woods  
bois  
Holzes  
maderas

|  |                           |
|--|---------------------------|
|  | <b>Y36</b> rovere<br>oak  |
|  | <b>Y34</b> noce<br>walnut |

piano / top / plateau / platte / plano

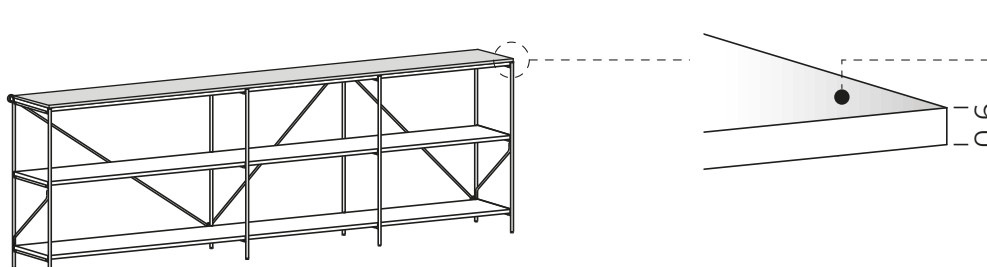

HPL

|  |                            |
|--|----------------------------|
|  | <b>L03</b> bianco<br>white |
|--|----------------------------|

Fenix®

|  |   |
|--|---|
|  | <b>L08</b> grigio Londra<br>London grey |
|  | <b>L06</b> nero<br>black                |

HPL + legno  
wood  
bois  
Holz  
madera

|  |  |
|--|--|
|  | <b>Y36</b> rovere<br>oak                   |
|  | <b>Y34</b> noce<br>walnut                  |
|  | <b>Y37</b> rovere affumicato<br>smoked oak |
|  | <b>Y38</b> rovere nero<br>black oak        |

HPL + metallo  
metal  
métal  
Metall  
metal

|  |                                       |
|--|---------------------------------------|
|  | <b>C31</b> ottone<br>brass            |
|  | <b>C32</b> ottone scuro<br>dark brass |
|  | <b>C35</b> inox<br>inox               |
|  | <b>C36</b> inox scuro<br>dark inox    |

HPL + ecotouch

|  |                              |
|--|------------------------------|
|  | <b>N01</b> sabbia<br>sand    |
|  | <b>N02</b> basalto<br>basalt |

HPL + cemento  
concrete  
ciment  
zement  
cemento

|  |   |
|--|---|
|  | <b>D01</b> bianco calce<br>lime white       |
|  | <b>D02</b> grigio Portland<br>Portland grey |

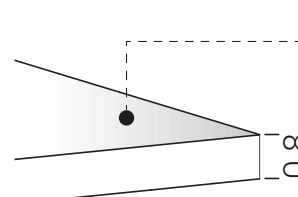

HPL + pietra naturale  
natural stone  
pierre naturelle  
Naturstein  
piedra natural

|  |  |
|--|--|
|  | <b>P01</b> grigio cenere<br>ash grey   |
|  | <b>P02</b> nero ardesia<br>slate black |









**XY**  
XY30

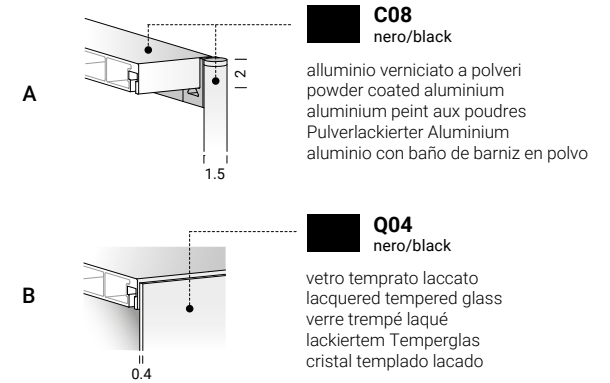
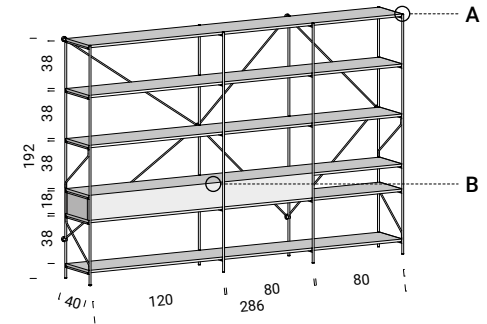

**C08**  
nero/black

alluminio verniciato a polveri  
powder coated aluminium  
aluminium peint aux poudres  
Pulverlackierter Aluminium  
aluminio con baño de barniz en polvo

**Q04**  
nero/black

vetro temprato laccato  
lacquered tempered glass  
verre trempé laqué  
lackiertem Temperglas  
cristal templado lacado

collection info  
pg. 50











**XY**  
XY31

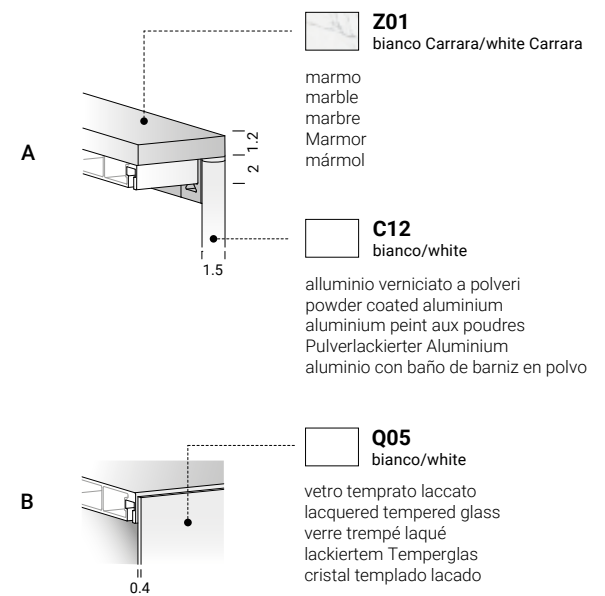
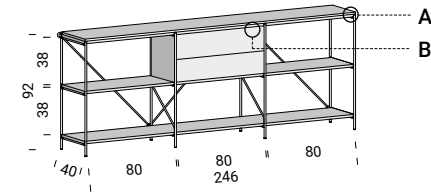

collection info  
pg. 50





**XY**  
XY29

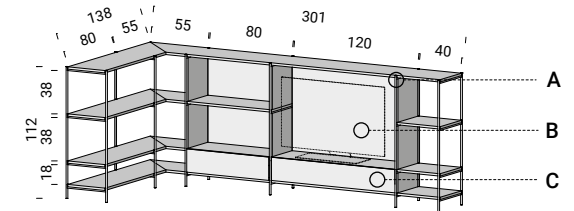

**A**

**C08**  
nero/black

alluminio verniciato a polveri  
powder coated aluminium  
aluminium peint aux poudres  
Pulverlackierter Aluminium  
aluminio con baño de barniz en polvo

**B**

**Y35**  
noce/walnut

MDF impiallacciato  
veneered MDF  
MDF plaqué  
MDF mit Furnier  
DM chapado

**C**

**Q04**  
nero/black

vetro temprato laccato  
lacquered tempered glass  
verre trempé laqué  
lackiertem Temperglas  
cristal templado lacado

collection info  
pg. 50











**XY**  
XY28

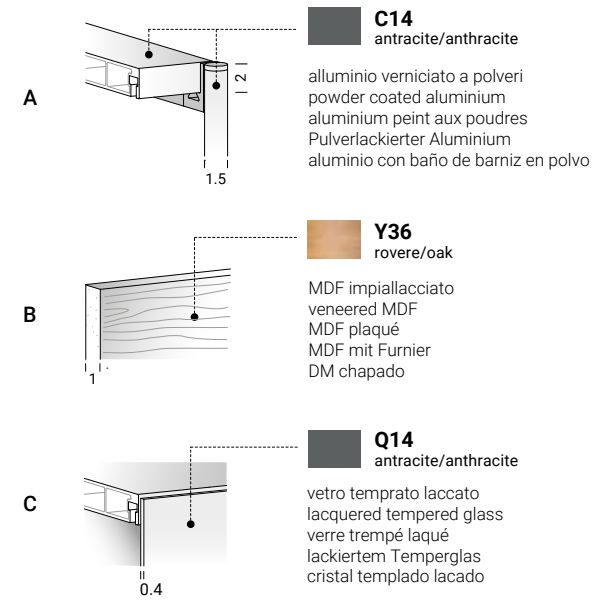
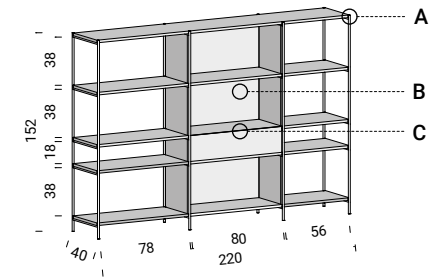

collection info  
pg. 50







**XY**  
XY02

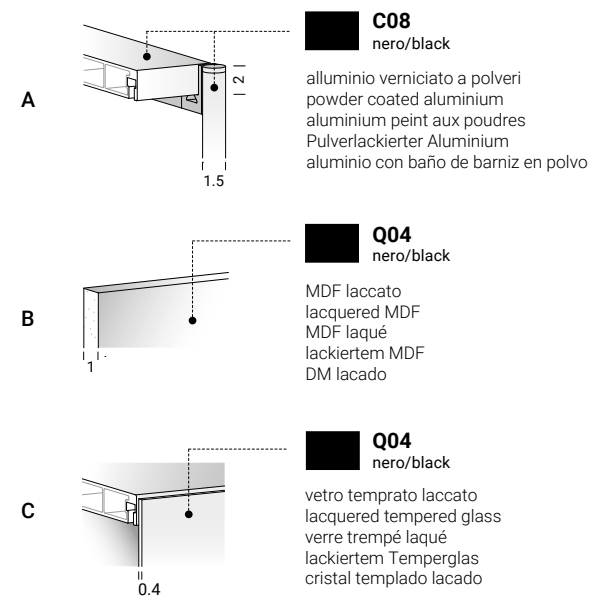
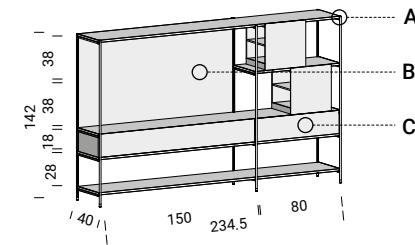

collection info  
pg. 50

**XY**  
XY10

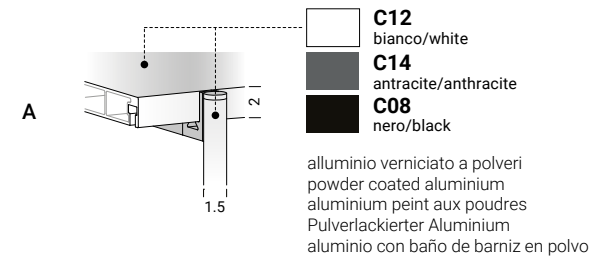
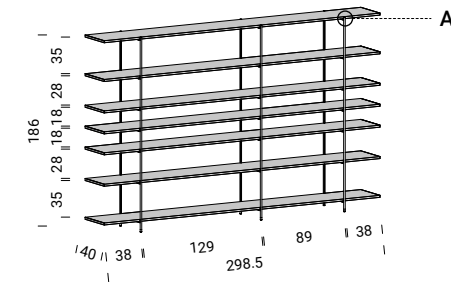

collection info  
pg. 50

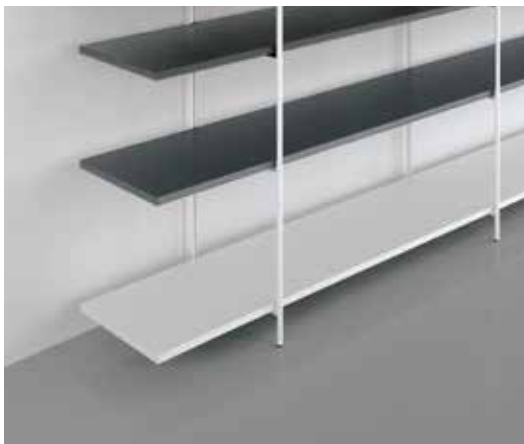



**XY**  
XY08

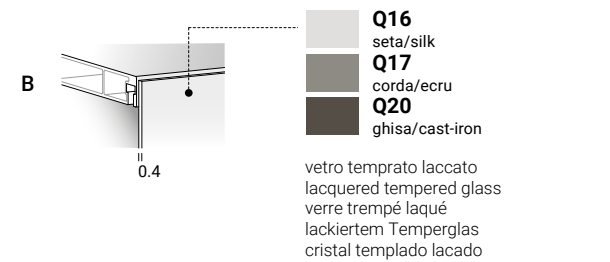
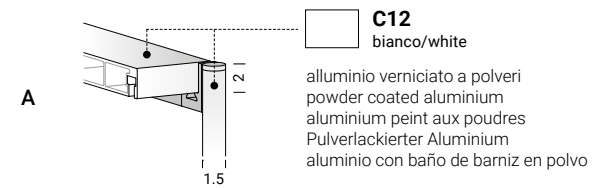
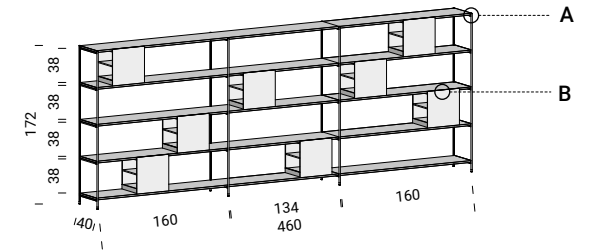

collection info  
pg. 50







**XY**  
XY09

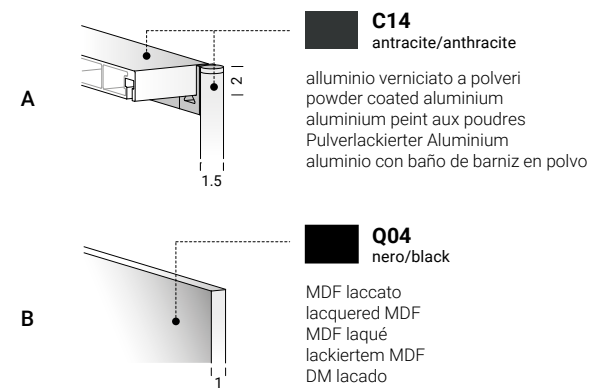
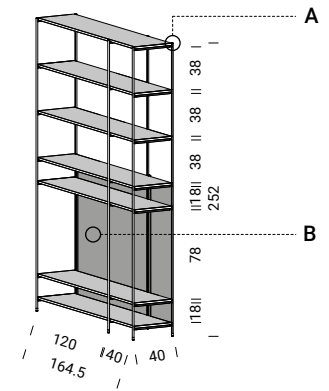

collection info  
pg. 50





# XY

XY03

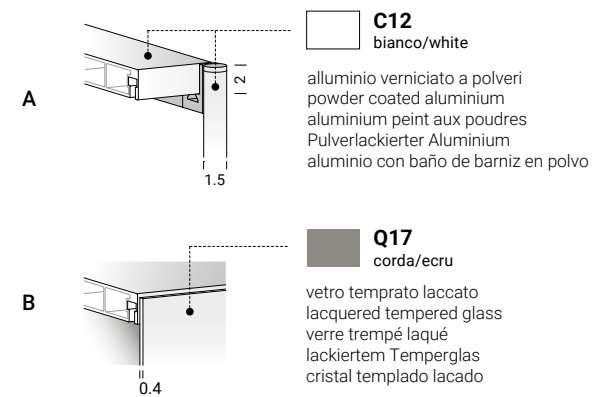
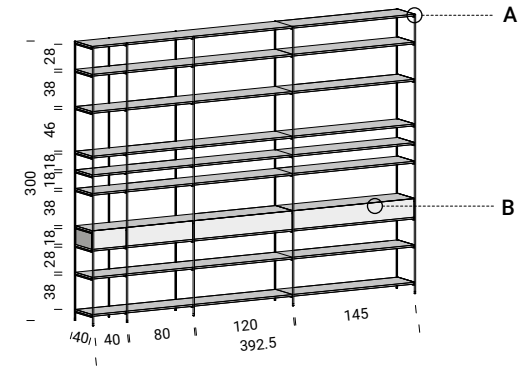

collection info  
pg. 50







## XY XY15

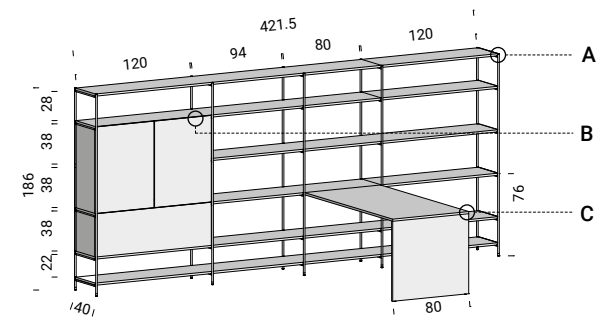

- A**
- C12**  
bianco/white
- alluminio verniciato a polveri  
powder coated aluminium  
aluminium peint aux poudres  
Pulverlackierter Aluminium  
aluminio con baño de barniz en polvo
- B**
- Q05**  
bianco/white
- vetro temprato laccato  
lacquered tempered glass  
verre trempé laqué  
lackiertem Temperglas  
cristal templado lacado
- C**
- Q05**  
bianco/white
- multistrato laccato  
lacquered multilayer  
multicouche laqué  
lackiertem Mehrschicht  
multiestrato lacado

collection info  
pg. 50



extendo  
patented  
product

# system

**Il sistema brevettato extendo è formato da due profili in alluminio estensibili, adattabili alle diverse altezze degli ambienti. Agendo sulla leva a scomparsa, i profili si bloccano all'altezza desiderata e si comprimono tra pavimento e soffitto, senza l'utilizzo di alcun utensile o pre-fissaggio.**

The patented extendo system consists of two extendable aluminium profiles that can be adapted to environments of various heights. Using the foldaway lever, the profiles can be blocked at the desired height and compressed between floor and ceiling, without having to use any kind of pre-fixing tool.

Le système breveté extendo est constitué de deux profilés extensibles en aluminium pouvant être adaptés aux différentes hauteurs des milieux. En agissant sur le levier escamotable, les profilés se verrouillent à la hauteur souhaitée et se compriment entre plancher et plafond, sans utiliser aucun outil ou préfixation.

El sistema patentado extendo está formado por dos perfiles de aluminio extensibles, adaptables a las distintas alturas de los ambientes. Actuando sobre la palanca escondida, los perfiles se bloquean a la altura deseada y se comprimen entre el suelo y el techo, sin que sea necesario utilizar ninguna herramienta o fijación previa.

Das patentierte System extendo besteht aus zwei ausziehbaren Aluminium-Profilen, die an unterschiedliche Raumhöhen angepasst werden können. Durch einen versenkbaren Hebel werden die Profile auf der gewünschten Höhe blockiert und zwischen Fußboden und Zimmerdecke ohne Werkzeug oder Vor-Befestigung komprimiert eingesetzt.



L'asta telescopica extendo esercita una spinta dinamica verso l'alto che consente di assorbire eventuali variazioni d'altezza tra pavimento e soffitto che possono avvenire nel corso del tempo. Per progettare senza vincoli ogni spazio, sono disponibili adattatori soffitto cartongesso, soffitto inclinato e a parete.

The extendo telescopic rod exerts dynamic upward pressure, so that it can absorb any height variations between the floor and ceiling that may occur over time. In order to design any space without limitations, adaptors are available for plasterboard ceilings, sloped ceilings and walls.

La tige télescopique extendo exerce une poussée dynamique vers le haut qui permet d'absorber les éventuelles variations de hauteur entre le plancher et le plafond susceptibles de se présenter au fil du temps. Pour concevoir tout espace sans contraintes, des adaptateurs pour plafond en placoplâtre, plafond incliné et pour application murale sont disponibles.

## system materials



alluminio  
aluminium  
Aluminium  
aluminio

Le materie prime che costituiscono il sistema system derivano da un processo di riutilizzo e sono a loro volta riciclabili.

The primary materials used in the system "system" are sourced from a reuse process, and are in turn recyclable.

Les matières premières qui composent le système system dérivent d'un processus de réutilisation et sont à leur tour recyclables.

Die Rohstoffe für das System "system" entstammen einem Wiederverwertungsprozess und sind Ihrerseits wiederum recyclebar.

Las materias primas que constituyen el sistema system proceden de un proceso de reutilización y son, a su vez, reciclables.

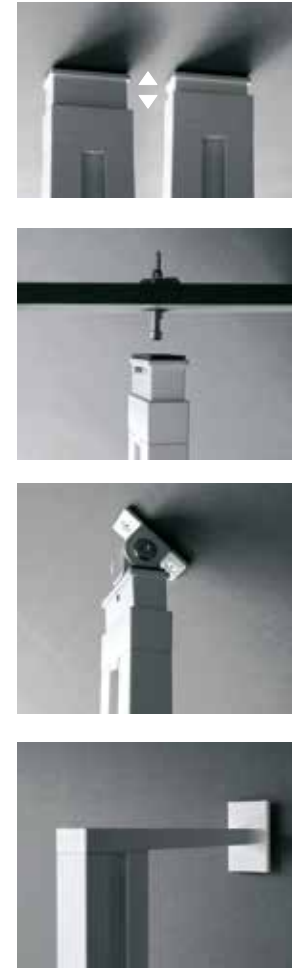

Die Teleskopstange extendo übt einen dynamischen Druck nach oben aus, wodurch mögliche Änderungen des Abstands zwischen Boden und Decke, wie sie im Lauf der Zeit auftreten können, aufgefangen werden. Um jeden Raum ohne Einschränkungen planen zu können, sind Adapter zur Befestigung an Decken aus Gipskarton, Dachschrägen und an Wänden erhältlich.

La barra telescópica extendo ejerce un empuje dinámico hacia arriba que permite absorber las variaciones de altura entre el suelo y el techo que se pueden dar con el tiempo. Para diseñar sin limitaciones cualquier espacio, existen adaptadores de cartón-yeso para techo, techo inclinado y pared.

Profilo extendo con attacco a parete disponibile in tre altezze o con supporto a pavimento autoportante.

Extendo profile with wall coupling available in three heights or with freestanding floor support.

Profilé extendo avec fixation murale disponible en trois hauteurs ou avec support au sol autoportant.

Das extendo Profil mit Wandbefestigung steht in drei verschiedenen Höhen oder mit selbsttragender Bodenhalterung zur Verfügung.

Perfil extendo con sujeción a pared disponible en tres alturas y con soporte autónomo al suelo.

**extendo**

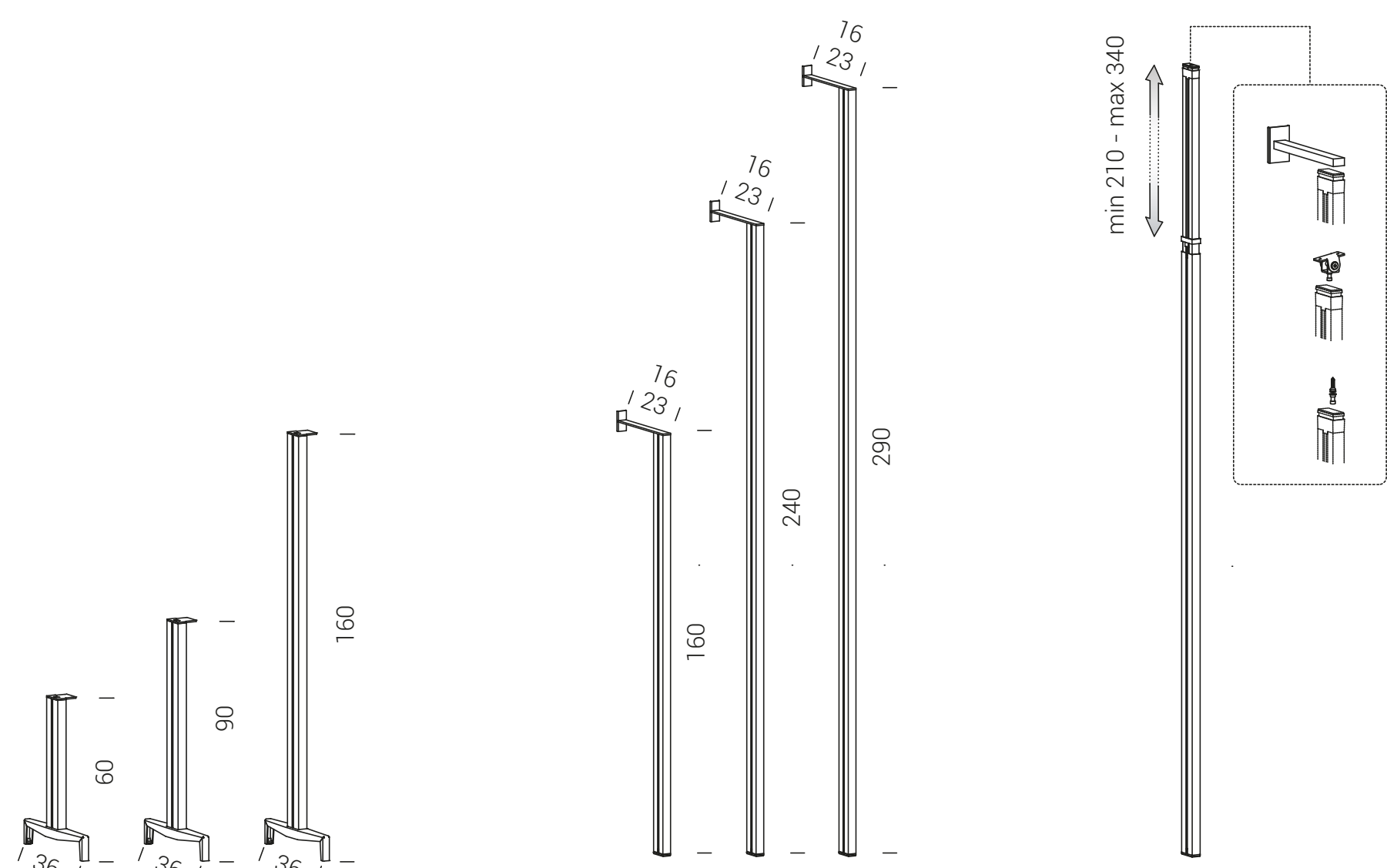

disponibili riduzioni a misura / tailor-made reduction available / disponibles réductions sur mesure  
 cm Verkleinerung nach Kundenwunsch / disponibles reducciones a medida

**ripiani in multistrato / multilayer shelves / étagères en multicouche  
 Böden aus Mehrschicht / estantes de multiestrato**

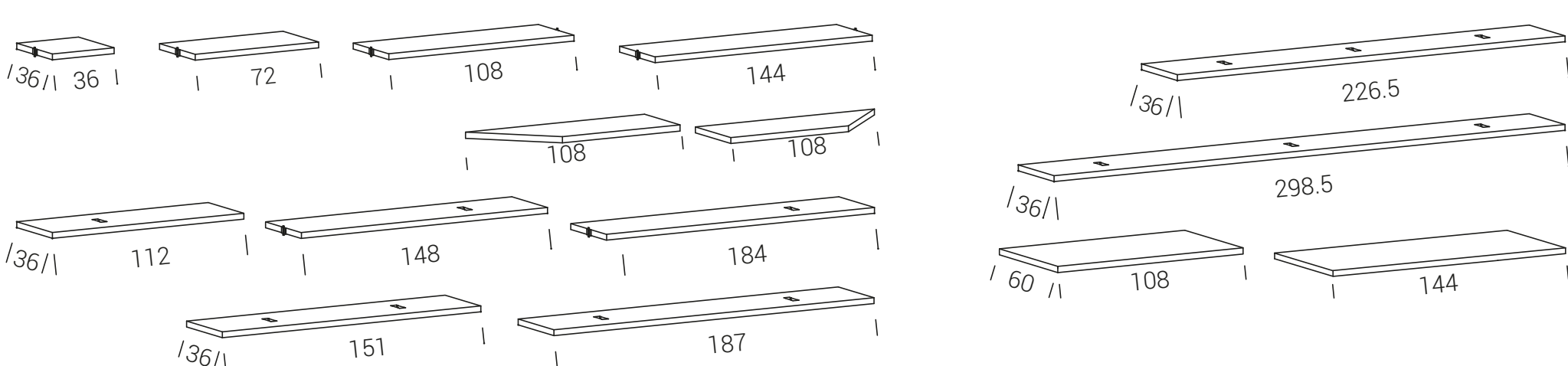

disponibili riduzioni a misura / tailor-made reduction available / disponibles réductions sur mesure  
 cm Verkleinerung nach Kundenwunsch / disponibles reducciones a medida

**ripiani in HPL/ HPL shelves / étagères / Böden / estantes**

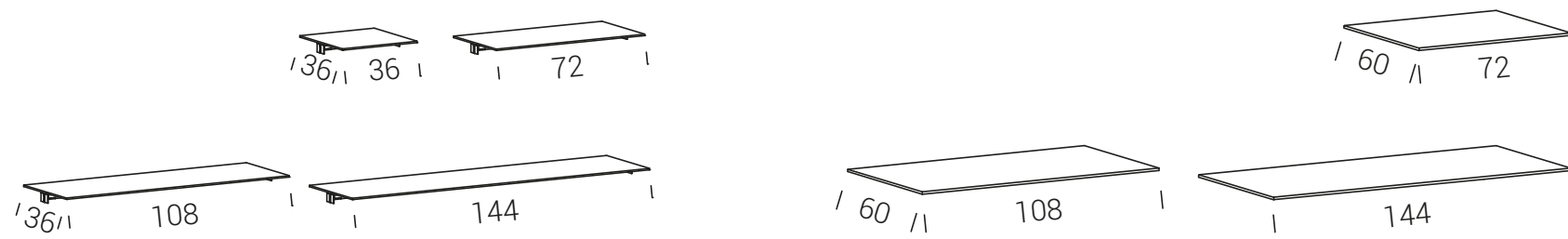

disponibili riduzioni a misura / tailor-made reduction available / disponibles réductions sur mesure  
 cm Verkleinerung nach Kundenwunsch / disponibles reducciones a medida

**ripiani in vetro / Glass shelves / étagères en verre / Böden aus Glas / estantes de cristal**

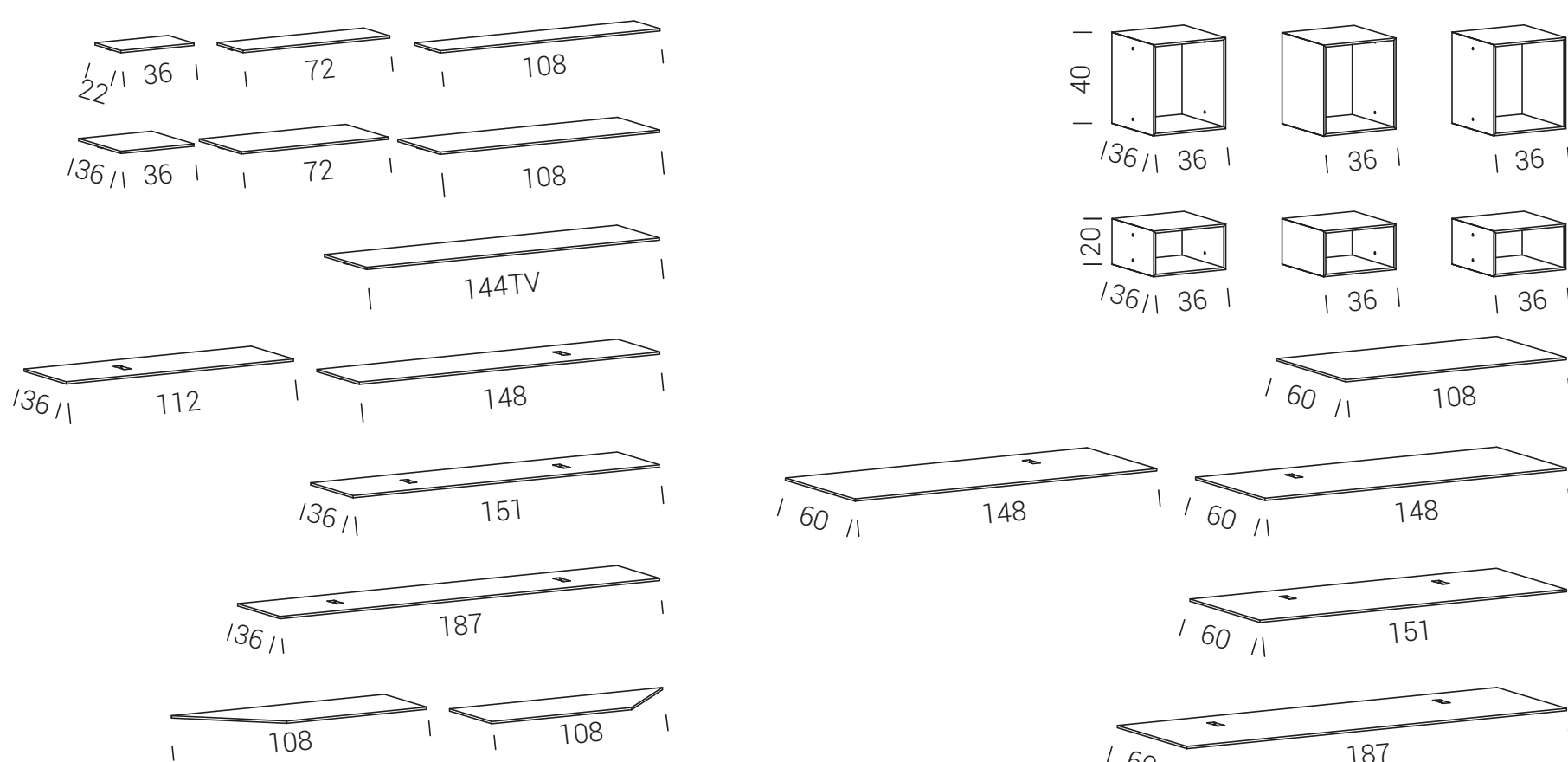

disponibili riduzioni a misura / tailor-made reduction available / disponibles réductions sur mesure  
 cm Verkleinerung nach Kundenwunsch / disponibles reducciones a medida

**ripiani in vetro con rinforzo / Glass shelves with reinforcement / étagères en verre avec renfort  
 Böden aus Glas verstärkt / estantes de cristal con refuerzo**

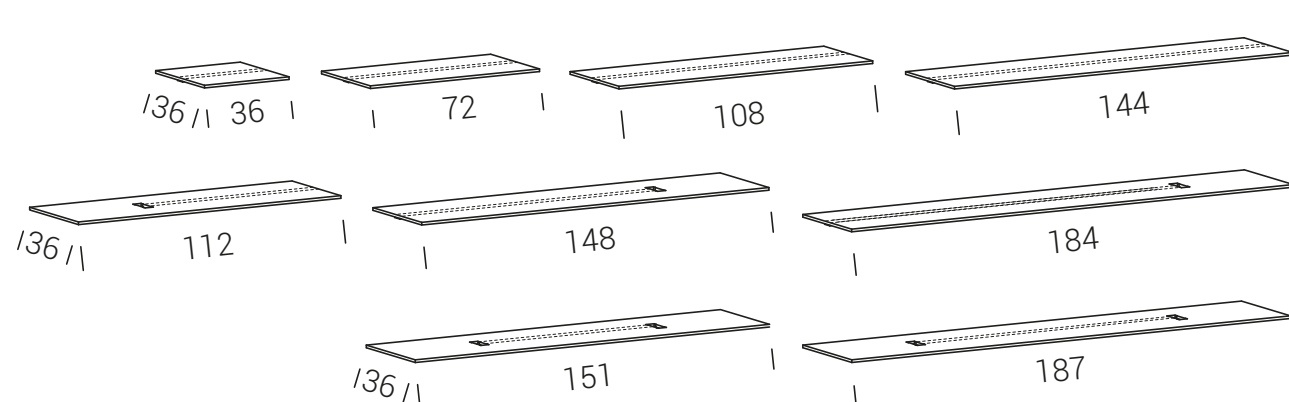

disponibili riduzioni a misura / tailor-made reduction available / disponibles réductions sur mesure  
 cm Verkleinerung nach Kundenwunsch / disponibles reducciones a medida

**pannello retro TV / TV rear panel / panneau arrière TV / Rückwand TV / panel trasero TV**

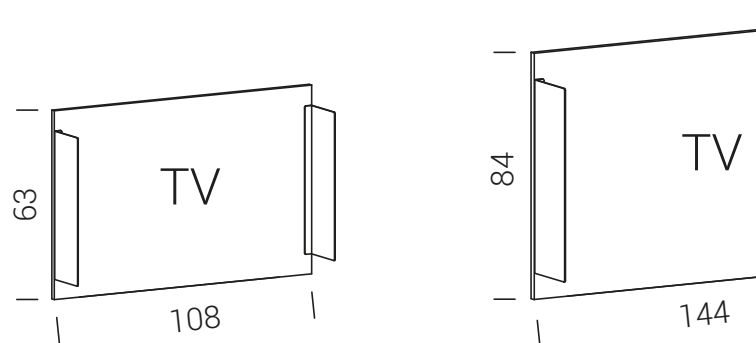

disponibili riduzioni a misura / tailor-made reduction available / disponibles réductions sur mesure  
 cm Verkleinerung nach Kundenwunsch / disponibles reducciones a medida

**contenitori / cabinets / modules de rangement / Behälter / contenedores**

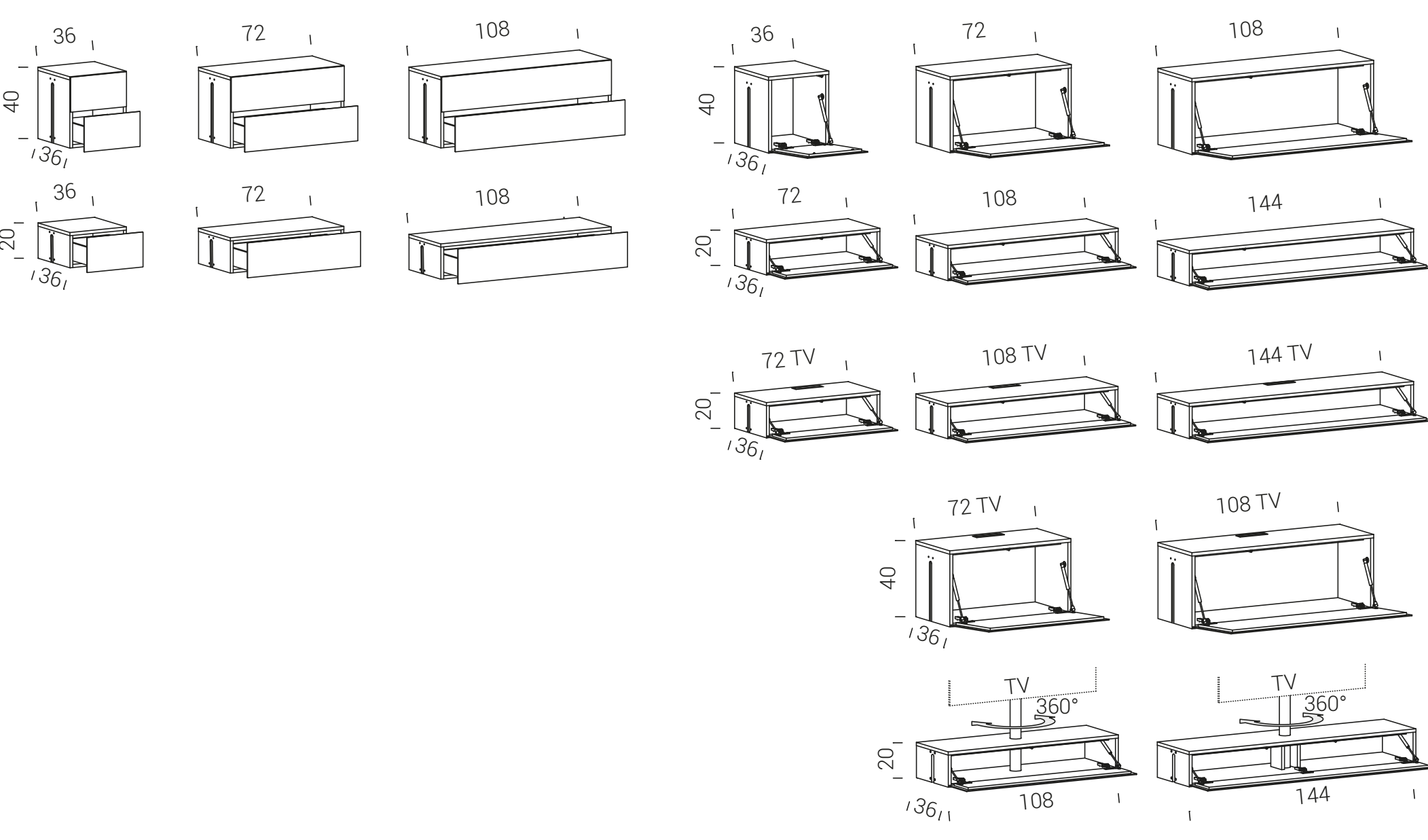

ripiani per contenitori / shelves for cabinets / étagères pour conteneur  
 Böden für Behälter / estantes para contenedores

**accessori / accessories / accessoires / Zubehör / accesorios**

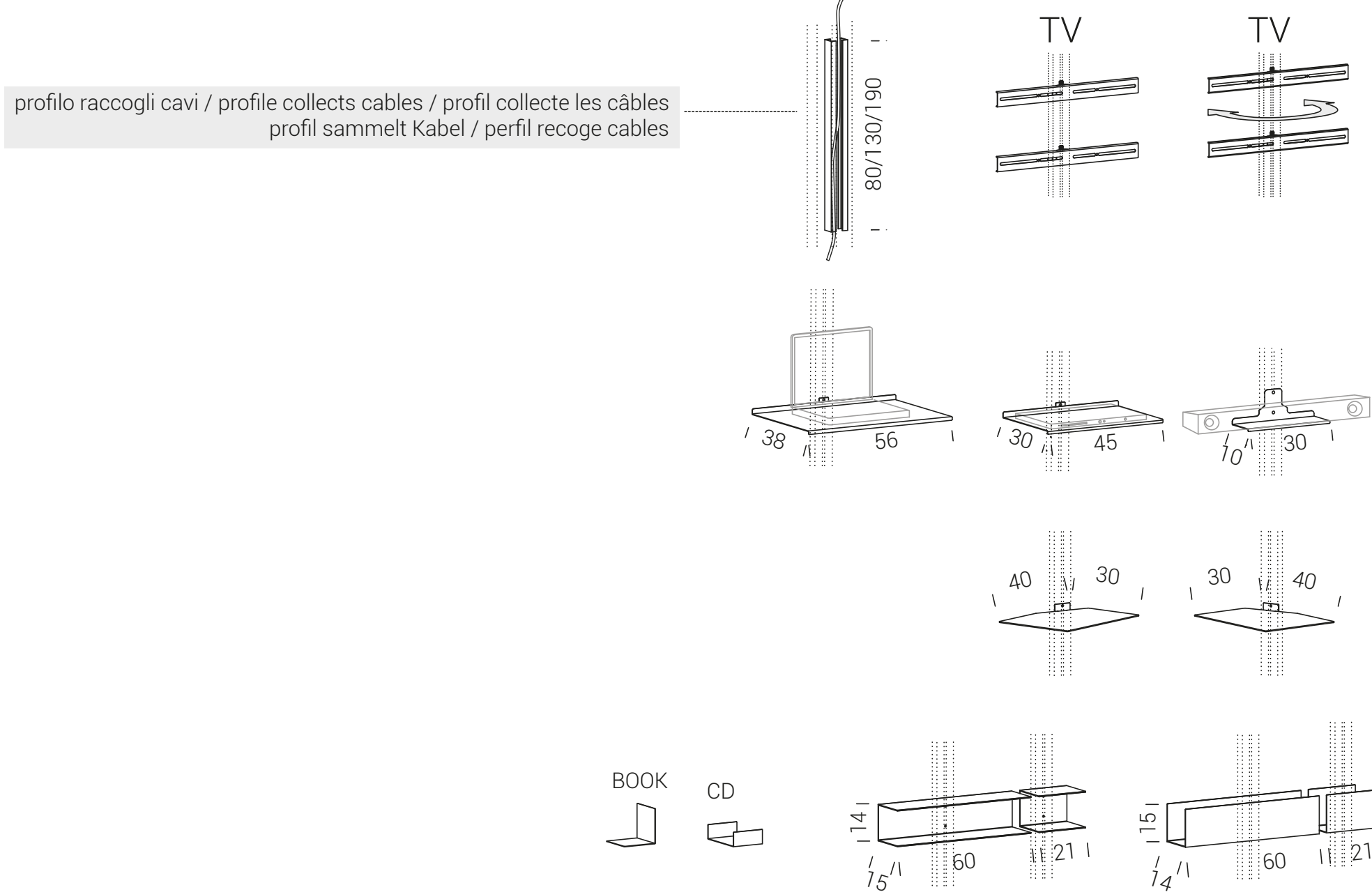



## extendo

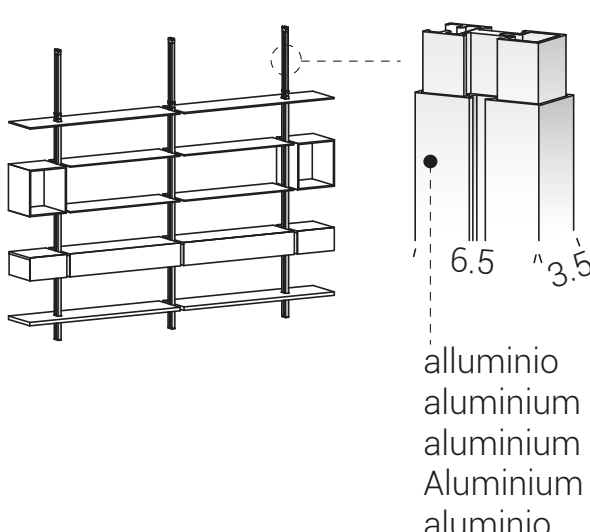

verniciato  
painted  
peint  
lackierter  
pintado

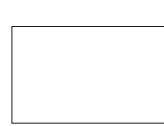

**C12** bianco  
white



**C21** seta  
silk



**C30** ghisa  
cast-iron



**C08** nero  
black

alluminio  
aluminium  
aluminium  
Aluminium  
aluminio

## ripiani in multistrato / multilayer shelves / étagères en multicouche Böden aus Mehrschicht / estantes de multiestrato

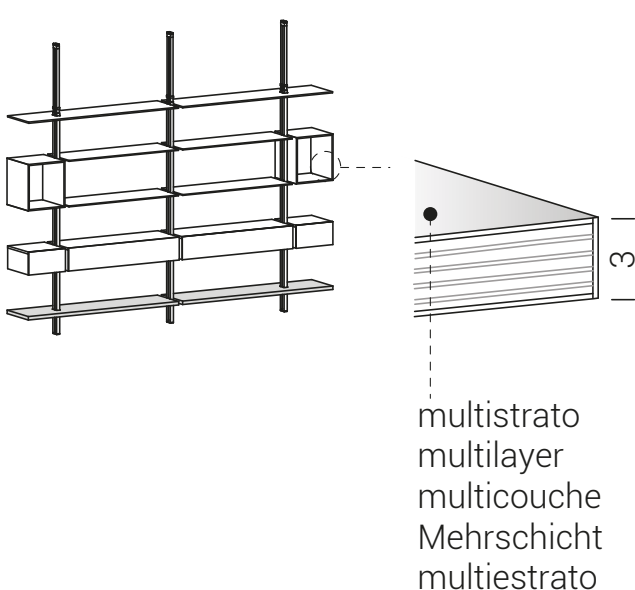

laccato  
lacquered  
laqué  
lackiert  
lacado

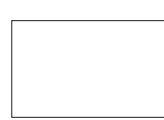

**Q05** bianco  
white

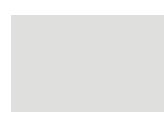

**Q16** seta  
silk



**Q17** corda  
ecru



**Q20** ghisa  
cast-iron



**Q14** antracite  
anthracite



**Q04** nero  
black



**Q21** bronzo  
bronze

multistrato  
multilayer  
multicouche  
Mehrschicht  
multiestrato

30 kg/ml

## ripiani in HPL / HPL shelves / étagères en HPL Böden aus HPL / estantes de HPL

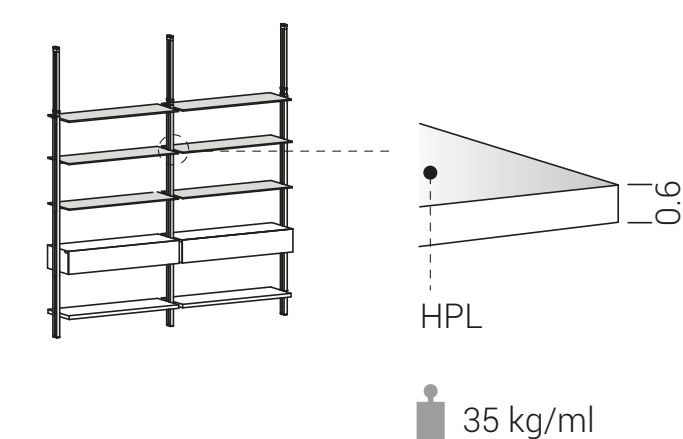

HPL



**L03** bianco  
white

Fenix®



**L08** grigio Londra  
London grey

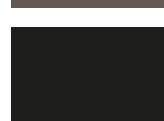

**L06** nero  
black

35 kg/ml

laccato  
lacquered  
laqué  
lackiert  
lacado



**Q05** bianco  
white



**Q16** seta  
silk



**Q17** corda  
ecru



**Q20** ghisa  
cast-iron



**Q14** antracite  
anthracite



**Q04** nero  
black



**Q21** bronzo  
bronze

essenze  
woods  
bois  
Holzes  
maderas



**Y36** rovere  
oak



**Y34** noce  
walnut

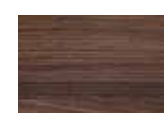

**Y37** rovere affumicato  
smoked oak



**Y38** rovere nero  
black oak

## ripiani in vetro / Glass shelves / étagères en verre Böden aus Glas / estantes de cristal

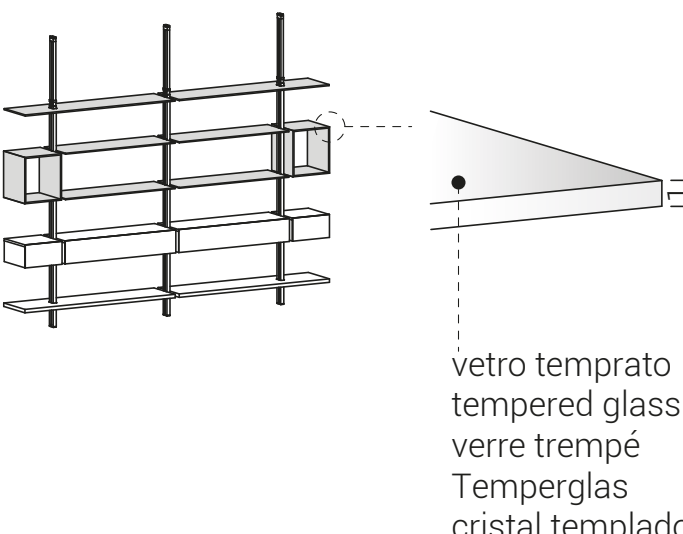

laccato  
lacquered  
laqué  
lackiertem  
lacado



**V01** bianco  
white



**V15** seta  
silk



**V16** corda  
ecru



**V23** ghisa  
cast-iron



**V12** antracite  
anthracite



**V02** nero  
black



**V24** bronzo  
bronze

vetro temprato  
tempered glass  
verre trempé  
Temperglas  
cristal templado

25 kg/ml



**V06** fumè  
smoked glass

## contenitori / cabinets / modules de rangement / Behälter / contenedores

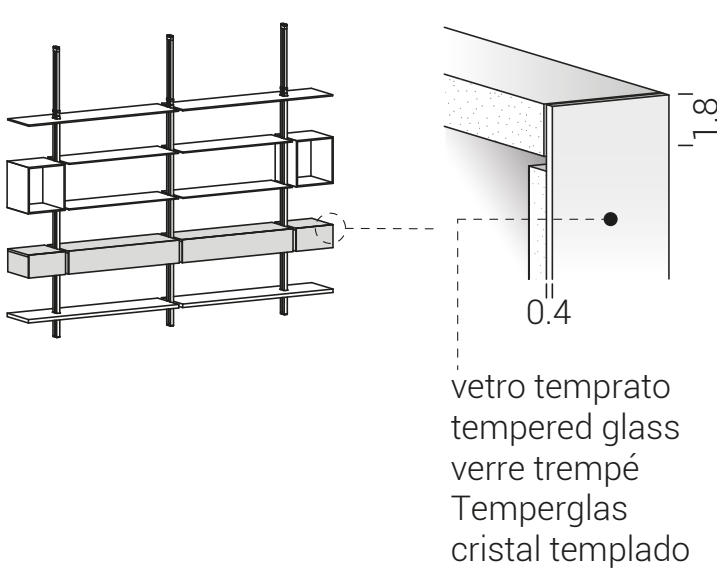

laccato  
lacquered  
laqué  
lackiertem  
lacado



**Q05** bianco  
white



**Q16** seta  
silk



**Q17** corda  
ecru



**Q20** ghisa  
cast-iron



**Q14** antracite  
anthracite



**Q04** nero  
black



**Q21** bronzo  
bronze

vetro temprato  
tempered glass  
verre trempé  
Temperglas  
cristal templado

essenze  
woods  
bois  
Holzes  
maderas



**Y37** rovere affumicato  
smoked oak

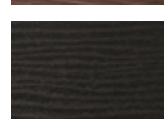

**Y38** rovere nero  
black oak

HPL

## accessori / accessories / accessoires / Zubehör / accesorios

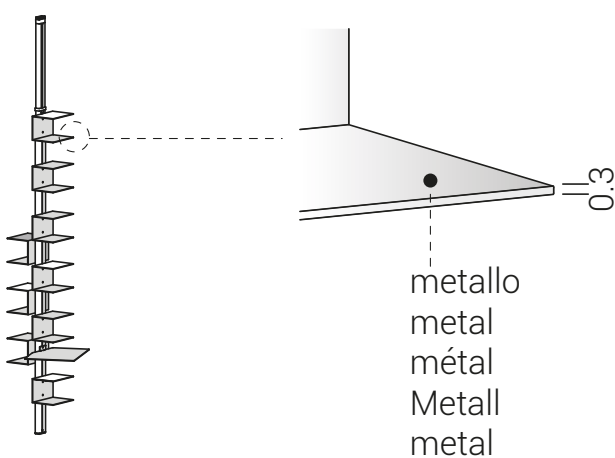

verniciato  
painted  
peint  
lackierter  
pintado



**C12** bianco  
white



**C21** seta  
silk



**C30** ghisa  
cast-iron



**C08** nero  
black

metallo  
metal  
métal  
Metall  
metal





## system SY54

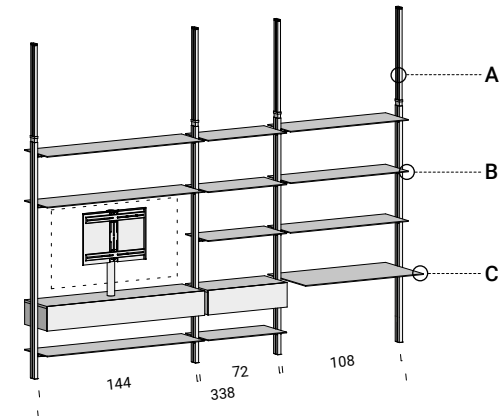

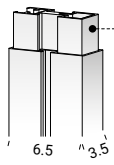
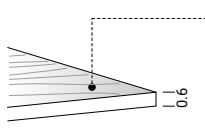
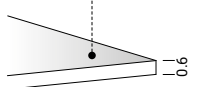
- A**
- 
- C08**  
nero/black
- alluminio verniciato a polveri  
powder coated aluminium  
aluminium peint aux poudres  
Pulverlackierter Aluminium  
aluminio con baño de barniz en polvo
- B**
- 
- Y37**  
rovere affumicato/smoked oak
- HPL impiallacciato  
wood-veneered HPL  
HPL plaqué bois  
HPL mit Holzfurnier  
HPL contrachapado madera
- C**
- 
- L06**  
nero/black
- HPL **FENIX** NTM®

collection info  
pg. 92













## system SY13

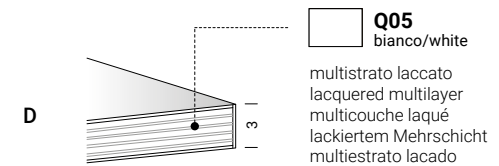
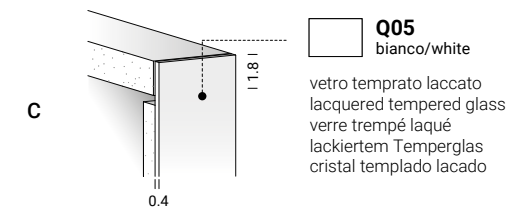
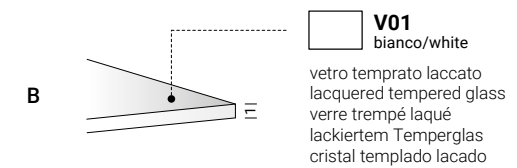
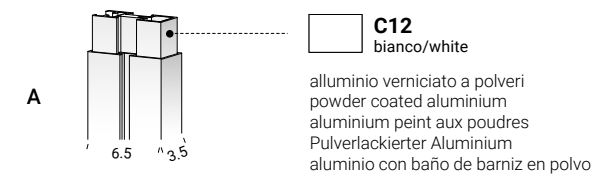
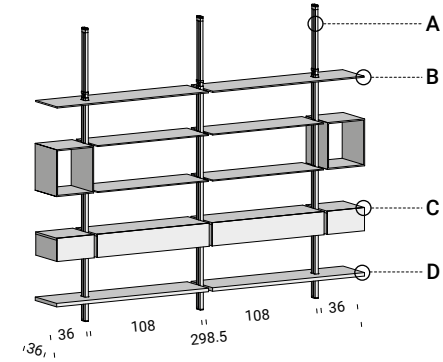







## system SY03

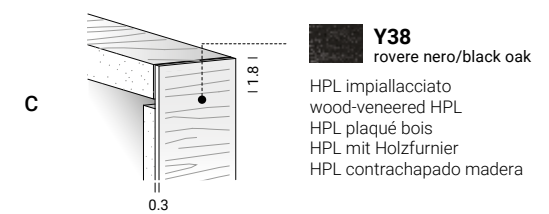
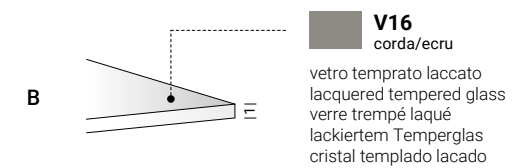
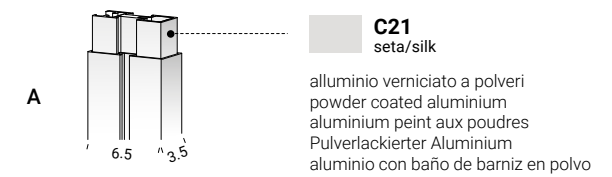
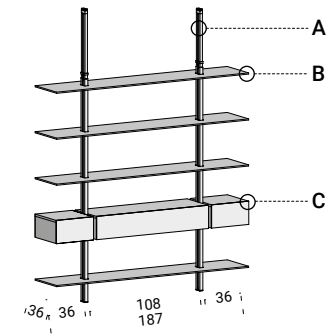

collection info  
pg. 92





## system SY04

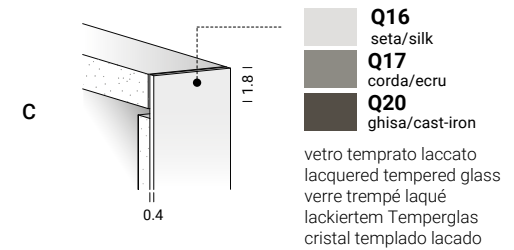
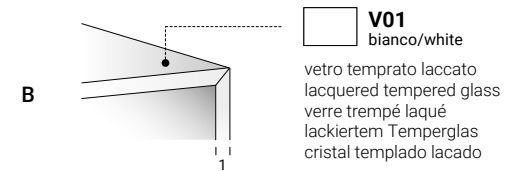
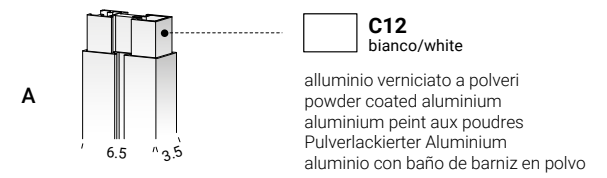
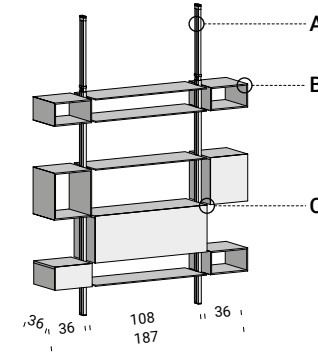

collection info  
pg. 92



## system SY16

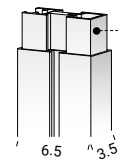
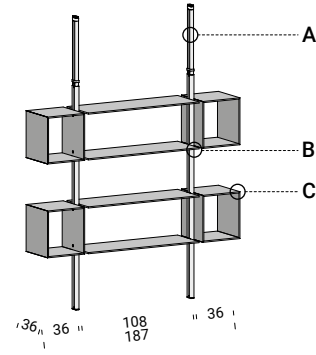

**C08**  
nero/black

alluminio verniciato a polveri  
powder coated aluminium  
aluminium peint aux poudres  
Pulverlackierter Aluminium  
aluminio con baño de barniz en polvo

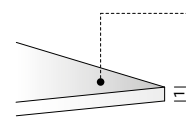

**V02**  
nero/black

vetro temprato laccato  
lacquered tempered glass  
verre trempé laqué  
lackiertem Temperglas  
cristal templado lacado

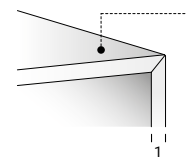

**V02**  
nero/black

vetro temprato laccato  
lacquered tempered glass  
verre trempé laqué  
lackiertem Temperglas  
cristal templado lacado

collection info  
pg. 92



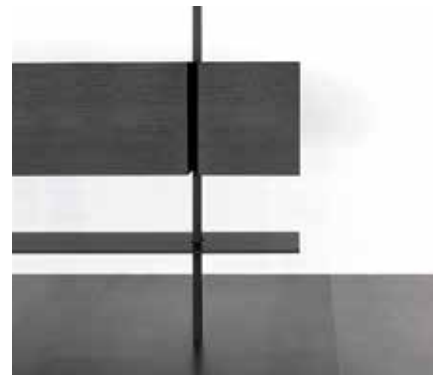

## system SY14

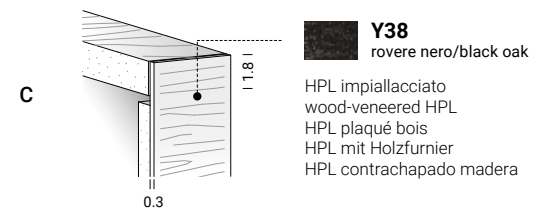
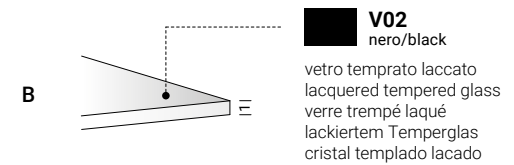
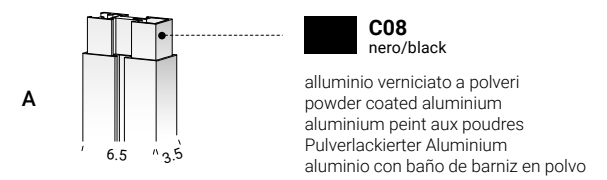
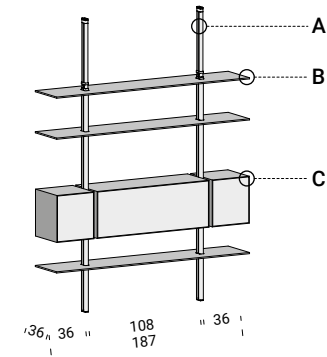

collection info  
pg. 92





## system SY02

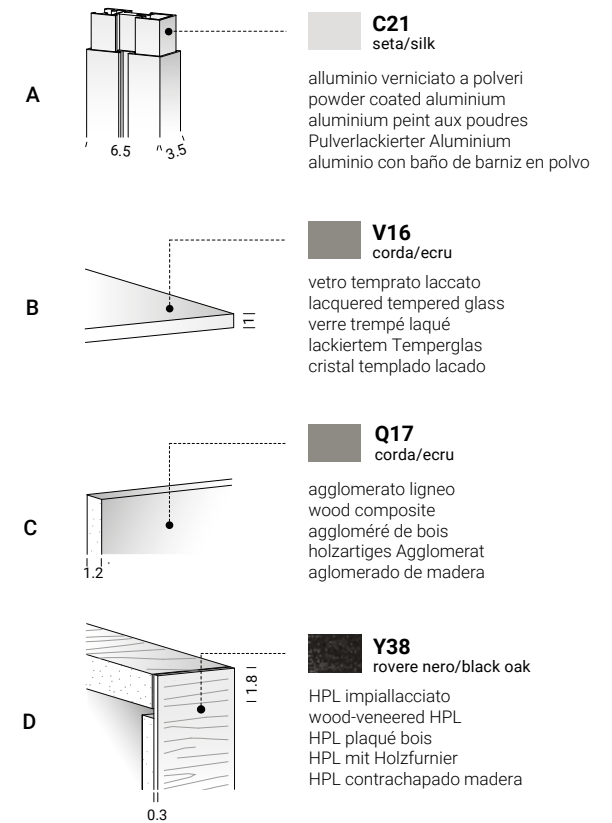
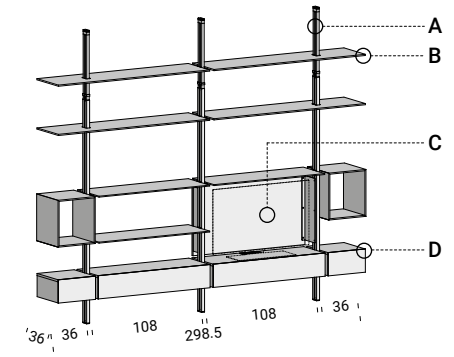

collection info  
pg. 92











## system SY52

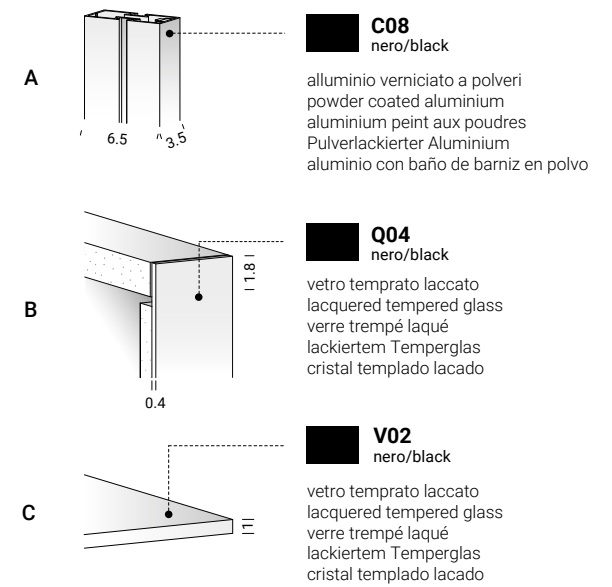
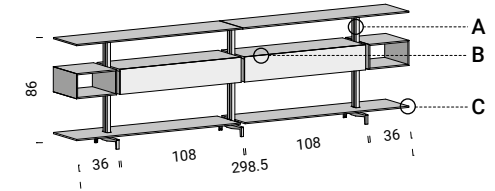

collection info  
pg. 92







## system SY53

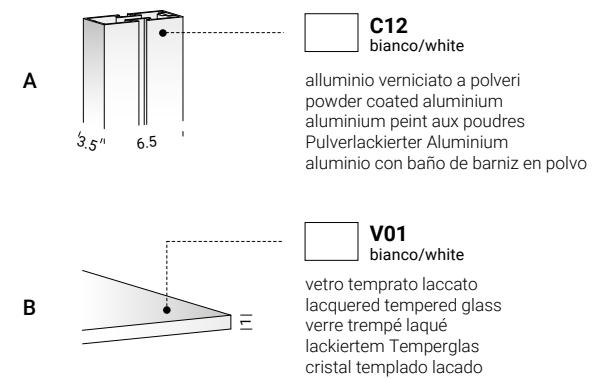
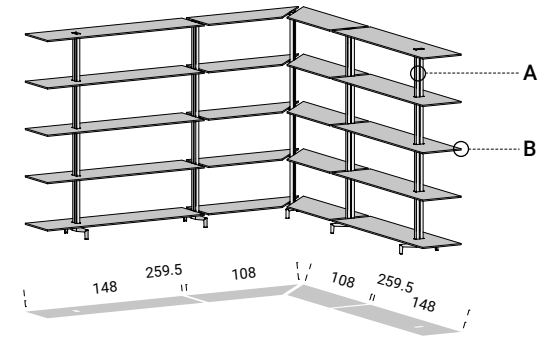

collection info  
pg. 92

# tables and coffee tables

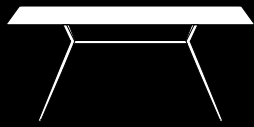

**balance**

pg. 118



**danske T**

pg. 194



**spillo**

pg. 134

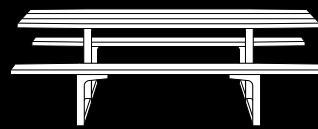

**hammer**

pg. 200



**sintesi**

pg. 152

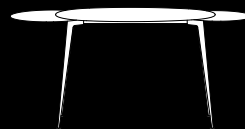

**mr. hyde**

pg. 210



**T7**

pg. 168



**spillo**

pg. 150



**T8**

pg. 174



**déco**

pg. 220



**IPE**

pg. 186



**mr. hyde**

pg. 216





# balance

**Il supporto in acciaio dei tavoli balance costituisce la base di un sistema di telai in grado di adattarsi in modo armonico e proporzionato a tutte le geometrie dei top disponibili. La sezione triangolare deriva dalla compressione di tubi a sezione circolare in acciaio, tale compressione aumenta la resistenza del supporto, conferendogli una silhouette elegante e leggera.**

The steel support of the Balance tables forms the base of a frame system capable of easily adapting to all the geometries of the tops available. The triangular section comes from compressing circular steel tubes. Such compression increases the strength of the support, giving it an elegant and light silhouette.

Le support en acier des tables balance constitue la base d'un système de structures en mesure de s'adapter de manière harmonieuse et proportionnée à toutes les géométries des plateaux disponibles. La section triangulaire dérive de la compression de tubes à section circulaire en acier, cette compression augmente la résistance du support en lui conférant une silhouette élégante et légère.

Die Stahlbeine der Tische balance bilden die Basis eines Rahmensystems, das sich allen Formen der angebotenen Abschlussborde harmonisch und proportioniert anpasst. Der dreieckige Querschnitt entsteht aus dem Druck der Stahlrohre mit rundem Querschnitt. Dieser Druck erhöht die Festigkeit des Halters und verleiht ihm eine elegante und leichte Silhouette.

El soporte de acero de las mesas Balance constituye la base de un sistema de bastidores que puede adaptarse armoniosamente proporcionado sobres disponibles para todo tipo de geometría. La sección triangular deriva de la compresión de tubos de acero de sección circular. Dicha compresión aumenta la resistencia del soporte, confiriéndole una silueta elegante y ligera.



disponibili riduzioni a misura  
tailor-made reduction available  
disponibles réductions sur mesure  
Verkleinerung nach Kundenwunsch  
Disponibles reducciones a medida

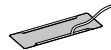

passacavo disponibile per tutti i top  
cable gland available for all tops  
passe-câble disponible pour tous les plateaux  
Kabeldurchlass für alle Abschlussborde verfügbar  
pasacables disponible para todos los sobres



iroko outdoor trattato ad olio 100% vegetale  
iroko outdoor treated with 100% vegetable oil  
iroko outdoor traité à l'huile 100% végétale  
Iroko Outdoor behandelt mit 100% pflanzlichem Öl  
Iroko para exteriores, tratado con aceite 100% vegetal

## materiali / materials



legno massiccio  
solid wood  
bois massif  
Massivholz  
madera maciza



HPL+legno  
HPL+wood  
HPL+bois  
HPL+Holz  
HPL+madera



HPL



acciaio  
steel  
acier  
Stahl  
acero

Le materie prime che costituiscono il sistema balance derivano da un processo di riutilizzo e sono a loro volta riciclabili.

The primary materials used in the system balance are sourced from a reuse process, and are in turn recyclable.

Les matières premières qui composent le système balance dérivent d'un processus de réutilisation et sont à leur tour recyclables.

Die Rohstoffe für das System balance entstammen einem Wiederverwertungsprozess und sind Ihrerseits wiederum recyclebar.

Las materias primas que constituyen el sistema balance proceden de un proceso de reutilización y son, a su vez, reciclables.



**tavoli / tables / tables / Tische / mesas**

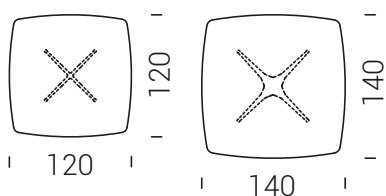
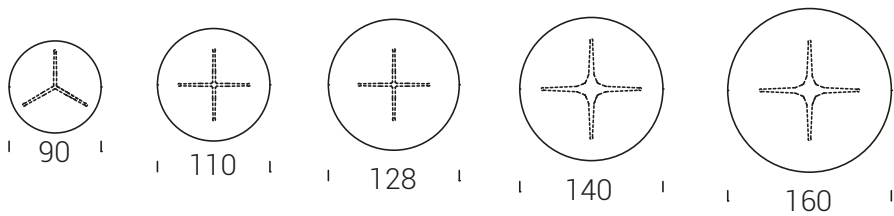
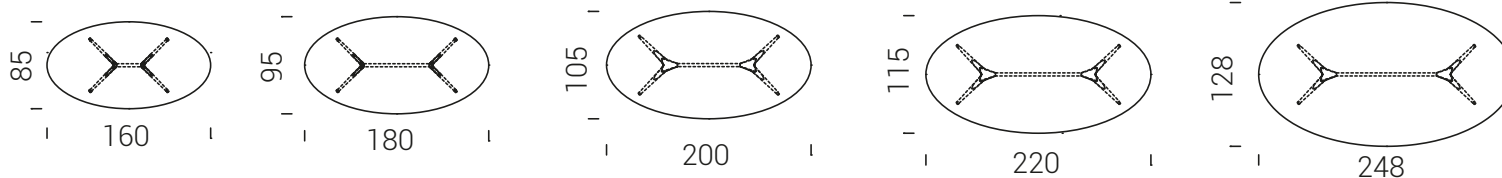
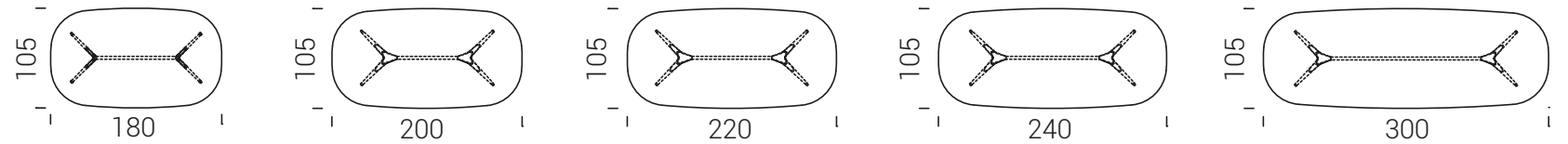
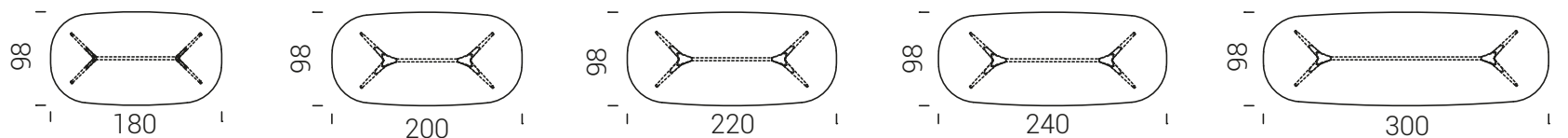
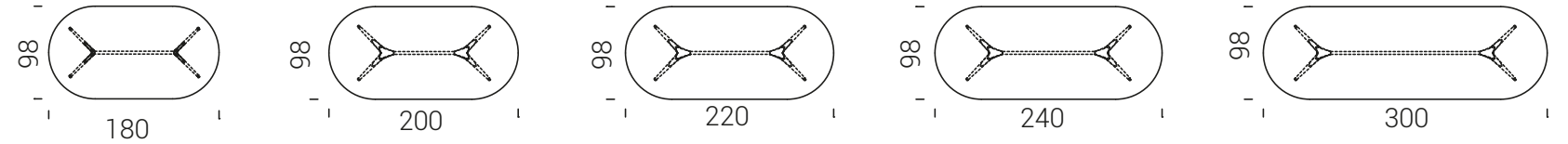
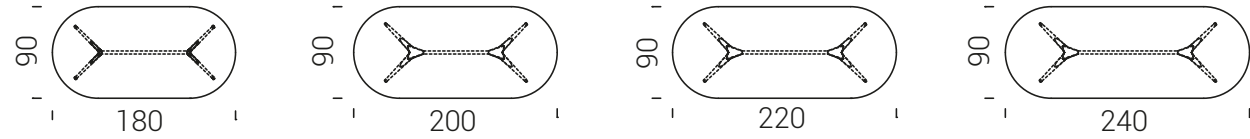
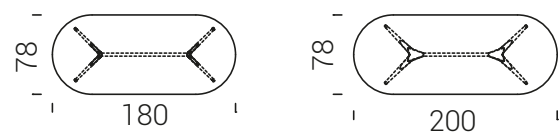
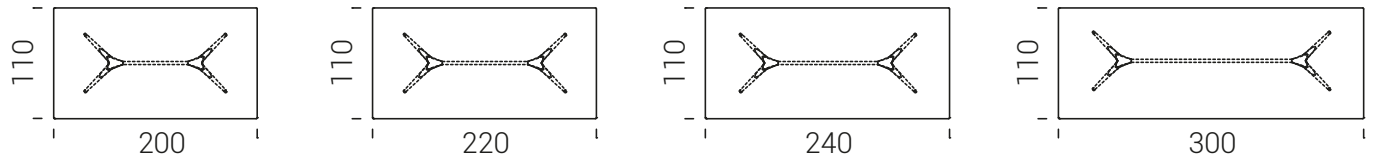
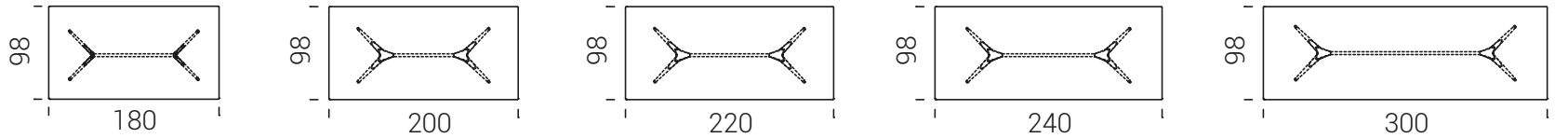
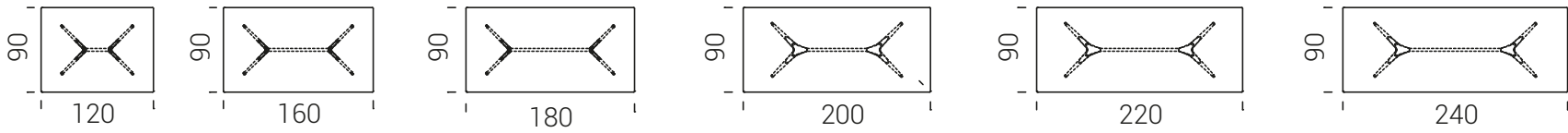
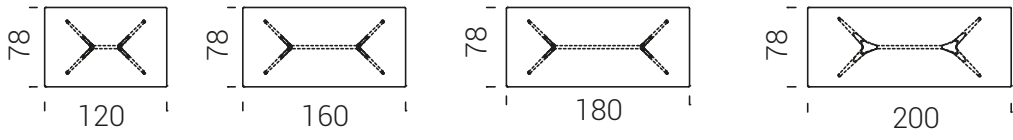
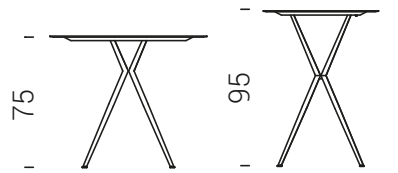
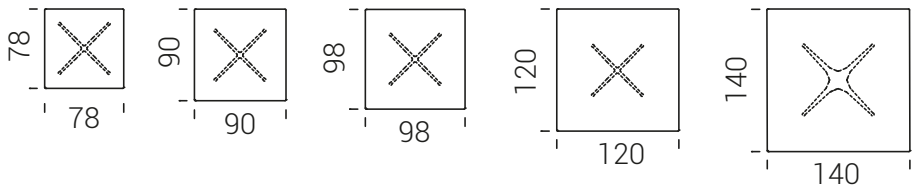

 alcuni tavoli sono realizzabili con altezza h=95 cm/some of the tables can be produced at a height of 95 cm/certaines tables sont réalisées avec une hauteur h=95 cm/ Einige Tische können mit einer Höhe von h=95 cm gefertigt werden/ algunas mesas se pueden realizar con altura h=95

**scrittoi / writing desks / secrétaires / Schreibtischen / escritorios**

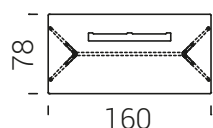
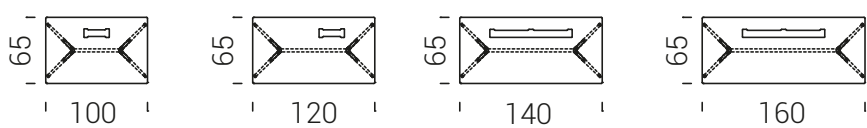

top tavolo / table top / plateaux de table / Tischplatte / plano de mesa

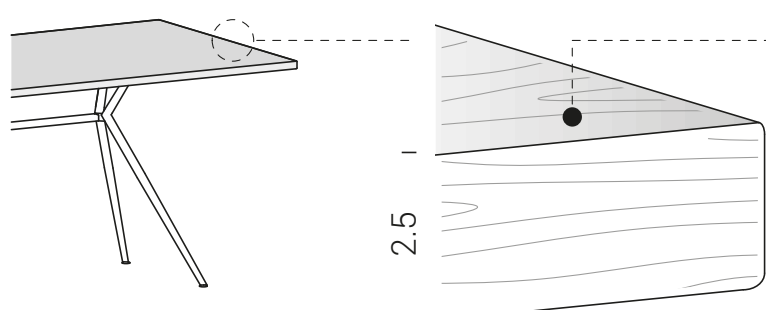

legno massiccio  
solid wood  
bois massif  
Massivholz  
madera maciza



**T01** rovere  
oak



**T02** noce  
walnut



**T03** iroko



**T04** iroko outdoor

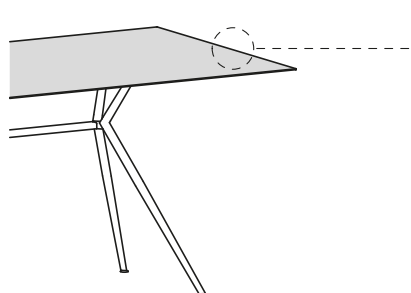

HPL



**L03** bianco  
white



Fenix®



**L08** grigio Londra  
London grey



**L06** nero  
black



HPL + legno  
wood  
bois  
Holz  
madera



**Y36** rovere  
oak



**Y34** noce  
walnut



**Y37** rovere affumicato  
smoked oak

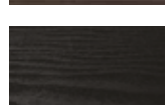

**Y39** frassino nero  
black arsh

HPL + metallo  
metal  
métal  
Metall  
metal



**C31** ottone  
brass



**C32** ottone scuro  
dark brass



**C35** inox  
inox



**C36** inox scuro  
dark inox



HPL + ecotouch



**N01** sabbia  
sand



**N02** basalto  
basalt

HPL + cemento  
concrete  
ciment  
zement  
cemento



**D01** bianco calce  
lime white



**D02** grigio Portland  
Portland grey

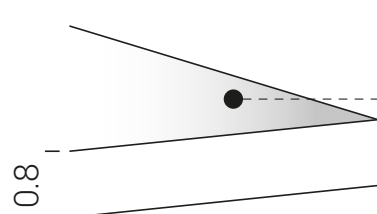

calcestruzzo  
beton  
béton  
Beton  
hormigón



**H01** quarzo  
quartz



**H02** arenaria  
brownstone



**H03** grafite  
graphite



HPL + pietra naturale  
natural stone  
pierre naturelle  
Naturstein  
piedra natural



**P01** grigio cenere  
ash grey

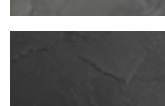

**P02** nero ardesia  
slate black



telaio / structure/ châssis / Gestell / bastidor

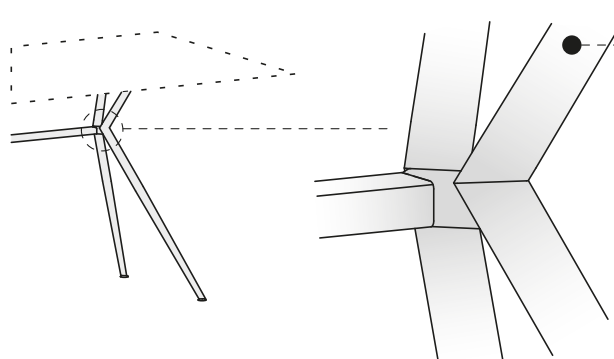

acciaio verniciato  
painted steel  
acier peint  
lackierter Stahl  
acero pintado



**C12** bianco  
white



**C21** seta  
silk



**C23** corda  
ecru



**C30** ghisa  
cast-iron



**C14** antracite  
anthracite



**C08** nero  
black



**C18** verde  
green



**C26** corten  
corten

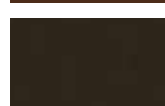

**C29** bronzo  
bronze



uso in esterno riparato  
protected outdoor use





## balance

BA08

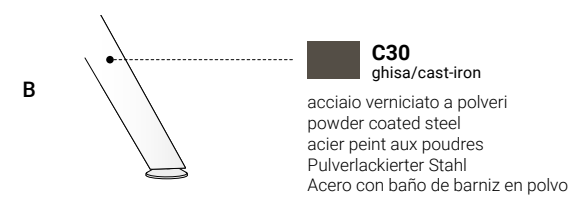
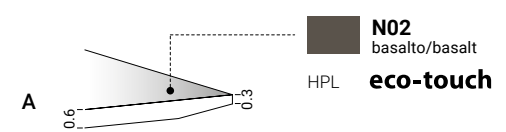
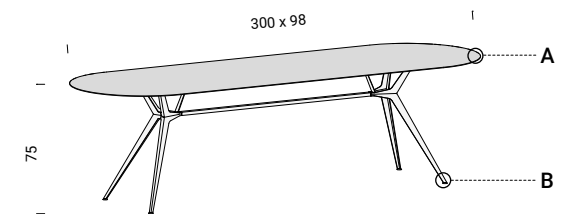

collection info  
pg. 118





## balance

BA02

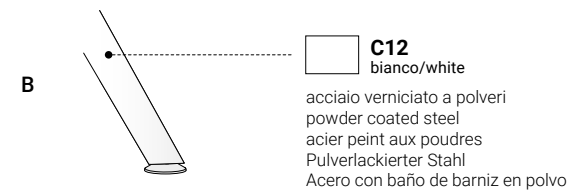
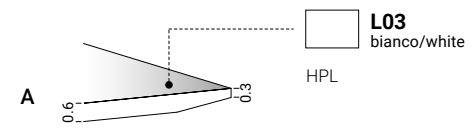
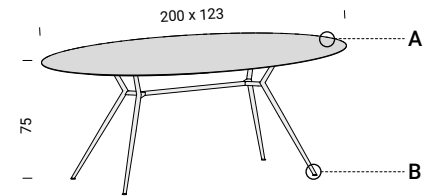

collection info  
pg. 118



## balance

BA03

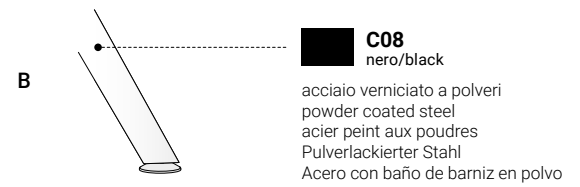
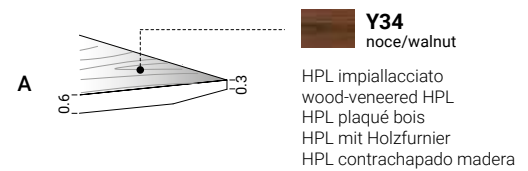
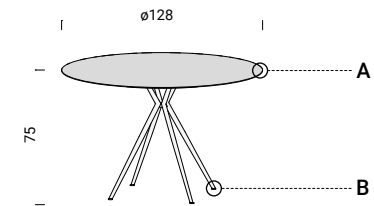

collection info  
pg. 118





## balance

BA01

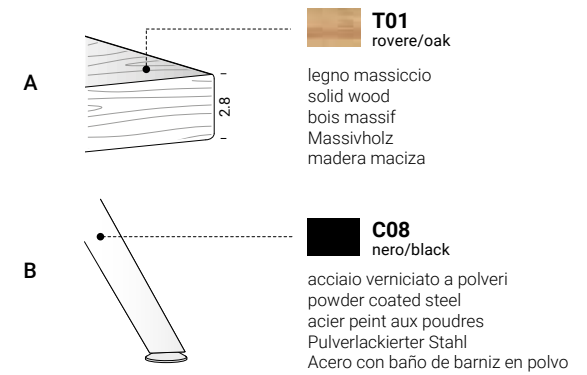
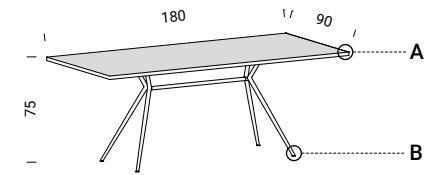

collection info  
pg. 118







## balance

BA04

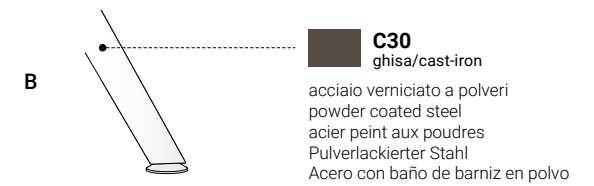
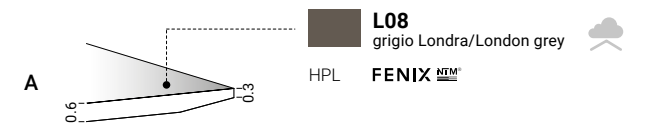
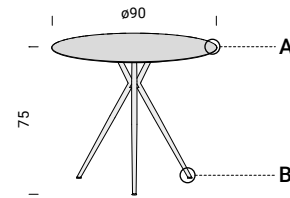

collection info  
pg. 118







## balance

BA06

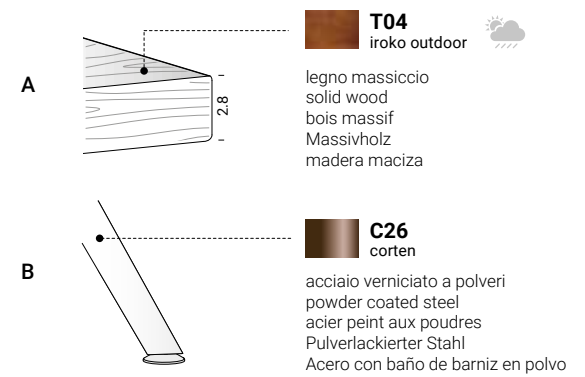
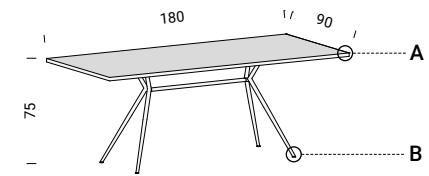

collection info  
pg. 118







## balance

BA05

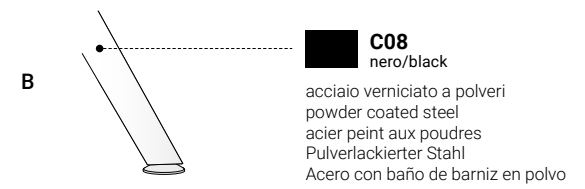
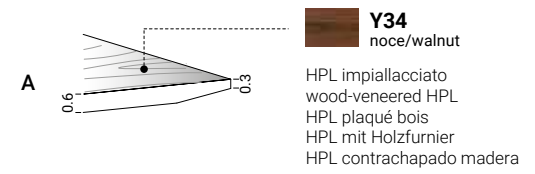
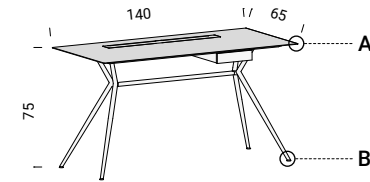

collection info  
pg. 118





## balance

BA07

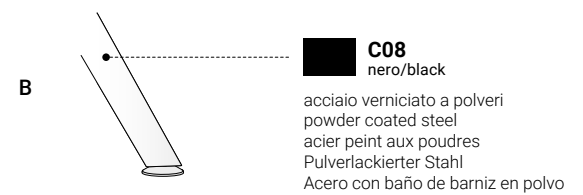
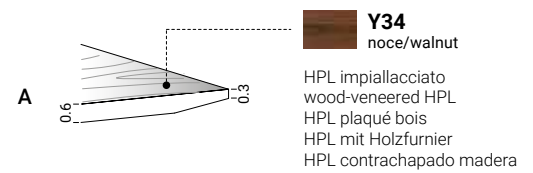
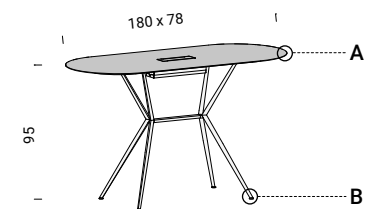

collection info  
pg. 118

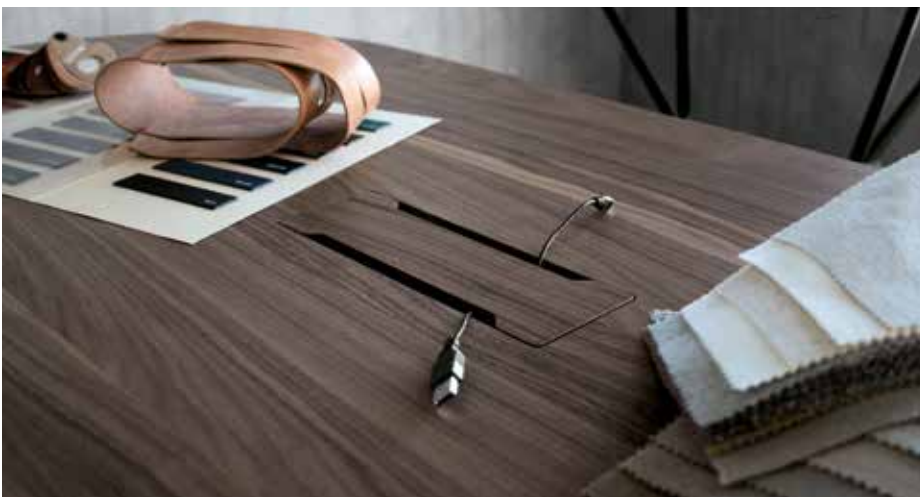





# spillo

**Spillo è un tavolo dai minimi ingombri volumetrici, il top in HPL ha un bordo perimetrale visibile di soli 3mm. Il telaio in acciaio sottostante ha geometrie che massimizzano la resistenza e la rigidità del top, consentendo lunghezze sino a 300 cm. Il telaio ed i supporti a forma conica in acciaio costituiscono un insieme della massima leggerezza volumetrica.**

The Spillo table offers minimum volume. The HPL top has a visible perimeter edge of just 3 mm. The underneath steel frame has geometries to maximise the strength and sturdiness of the top, allowing lengths up to 300 cm. The frame and the supports, which are made of steel and conical in shape, give an overall maximum volumetric lightness.

Spillo est une table présentant un encombrement volumétrique minimum, le plateau en HPL a un bord périphérique visible de 3mm seulement. La structure inférieure en acier présente des géométries qui augmentent au maximum la résistance et la rigidité du plateau, permettant des longueurs allant jusqu'à 300 cm. La structure et les supports de forme conique en acier constituent un ensemble de la plus grande légèreté volumétrique.

Spillo ist ein Tisch mit einem minimalem Platzbedarf, das Abschlussbord aus HPL hat eine sichtbare Konturführung von nur 3 mm. Die Geometrien des darunter liegenden Rahmens aus Stahl maximieren die Widerstandsfähigkeit und Steifheit des Abschlussbords und ermöglichen somit Längen von bis zu 300 cm. Die Rahmen und konischen Stützen aus Stahl bilden eine Einheit mit maximaler, volumetrischer Leichtigkeit.

Spillo es una mesa de dimensiones volumétricas mínimas. El sobre de HPL tiene un borde perimetral visible de solo 3 mm. El bastidor inferior de acero posee unas geometrías que maximizan la resistencia y la rigidez del sobre, permitiendo longitudes de hasta 300 cm. El bastidor y los soportes cónicos de acero componen un conjunto de máxima ligereza volumétrica.

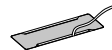

passacavo disponibile per tutti i top  
cable gland available for all tops  
passe-câble disponible pour tous les plateaux  
Kabeldurchlass für alle Abschlussborde verfügbar  
pasacables disponible para todos los sobres

## materiali / materials



HPL+legno  
HPL+wood  
HPL+bois  
HPL+Holz  
HPL+madera



HPL



acciaio  
steel  
acier  
Stahl  
acero

Le materie prime che costituiscono il sistema spillo derivano da un processo di riutilizzo e sono a loro volta riciclabili.

The primary materials used in the system spillo are sourced from a reuse process, and are in turn recyclable.

Les matières premières qui composent le système spillo dérivent d'un processus de réutilisation et sont à leur tour recyclables.

Die Rohstoffe für das System spillo entstammen einem Wiederverwertungsprozess und sind ihrerseits wiederum recyclebar.

Las materias primas que constituyen el sistema spillo proceden de un proceso de reutilización y son, a su vez, reciclables.

tavoli / tables / tables / Tische / mesas

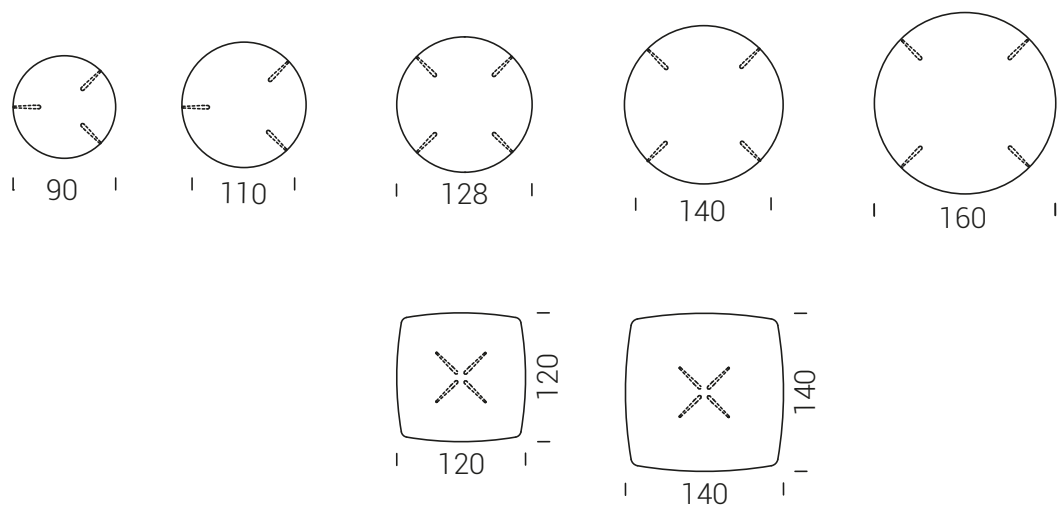
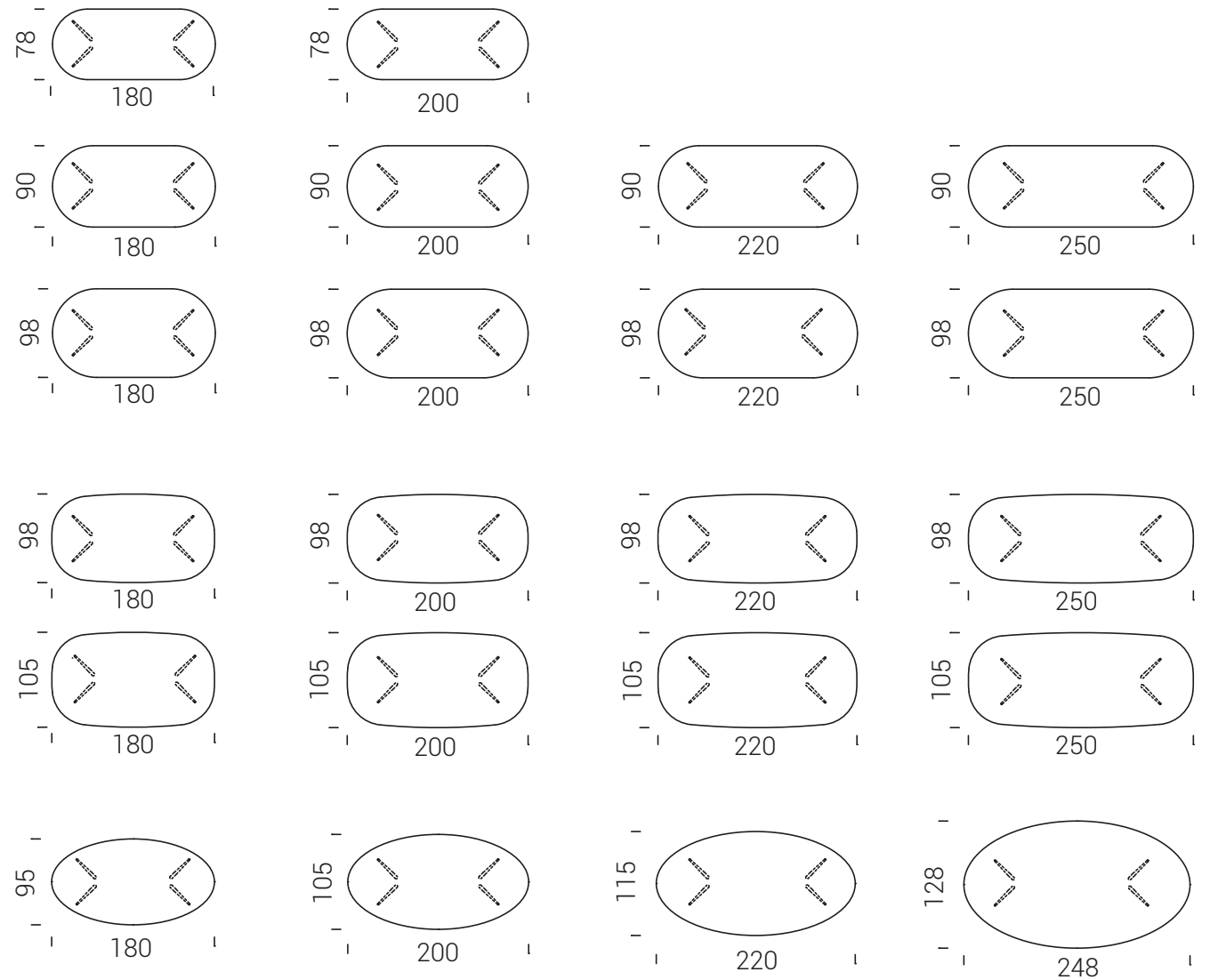
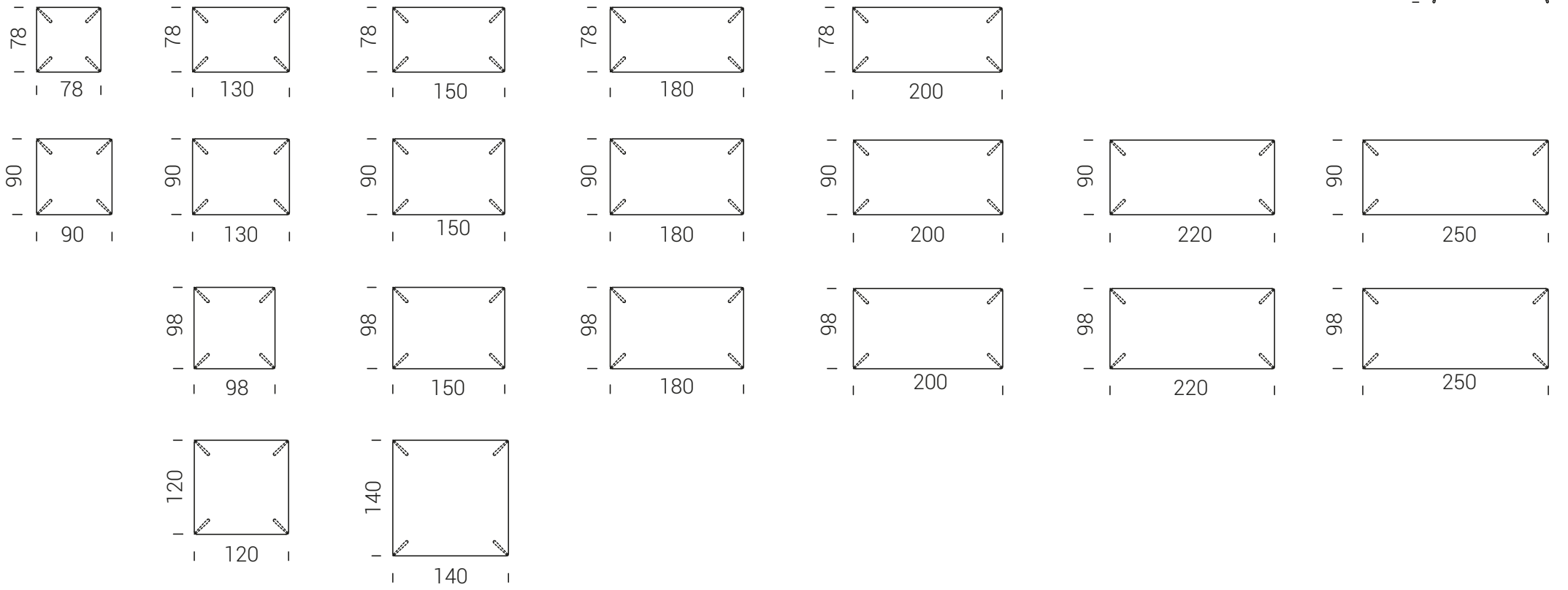

tavoli bassi/ coffee tables / tables basses / Couchtische / mesas bajas

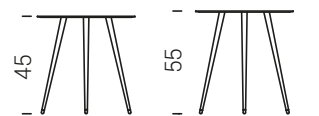
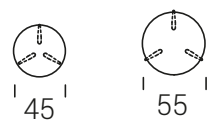

tavoli bassi/ coffee tables / tables basses / Couchtische / mesas bajas

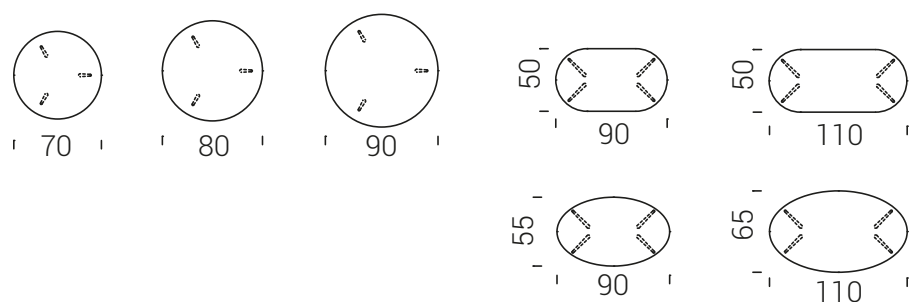

top tavolo / table top / plateaux de table / Tischplatte / plano de mesa

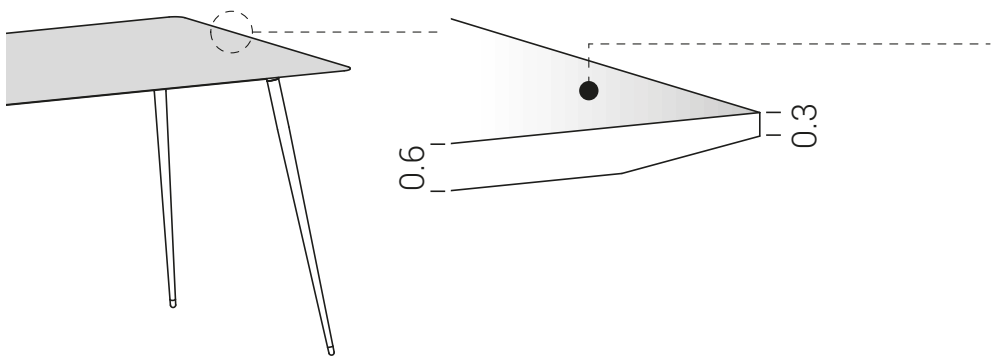

HPL

Fenix®

HPL + legno  
wood  
bois  
Holz  
madera

HPL + metallo  
metal  
métal  
Metall  
metal

HPL + ecotouch

HPL + cemento  
concrete  
ciment  
zement  
cemento

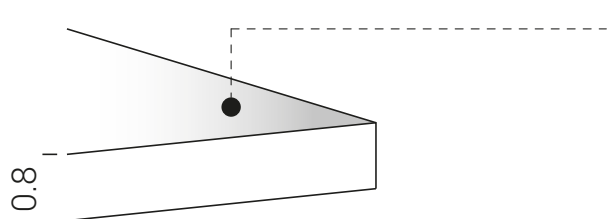

calcestruzzo  
beton  
béton  
Beton  
hormigón

HPL + pietra naturale  
natural stone  
pierre naturelle  
Naturstein  
piedra natural



**L03** bianco  
white



**L08** grigio Londra  
London grey



**L06** nero  
black



**Y36** rovere  
oak



**Y34** noce  
walnut



**Y37** rovere affumicato  
smoked oak



**Y39** frassino nero  
black ash



**C31** ottone  
brass



**C32** ottone scuro  
dark brass



**C35** inox  
inox



**C36** inox scuro  
dark inox



**N01** sabbia  
sand



**N02** basalto  
basalt



**D01** bianco calce  
lime white



**D02** grigio Portland  
Portland grey



**H01** quarzo  
quartz



**H02** arenaria  
brownstone



**H03** grafite  
graphite



**P01** grigio cenere  
ash grey



**P02** nero ardesia  
slate black



telaio / structure/ châssis / Gestell / bastidor

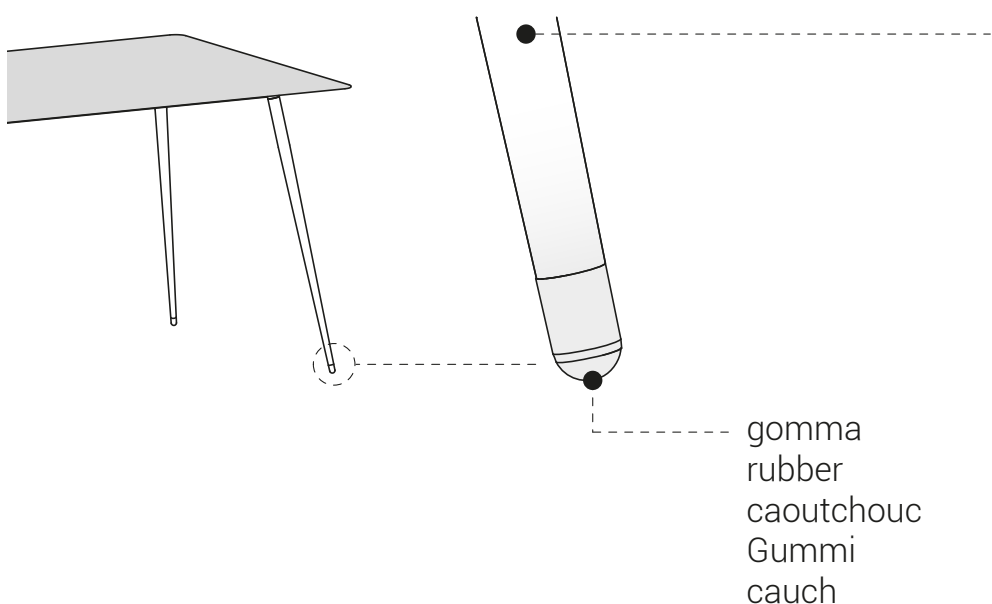

acciaio verniciato  
painted steel  
acier peint  
lackierter Stahl  
acero pintado

gomma  
rubber  
caoutchouc  
Gummi  
cauch



**C12** bianco  
white



**C21** seta  
silk



**C23** corda  
ecru



**C30** ghisa  
cast-iron



**C14** antracite  
anthracite



**C08** nero  
black



**C18** verde  
green



**C26** corten  
corten



**C29** bronzo  
bronze



uso in esterno riparato  
sheltered outdoor use







## spillo

SP24

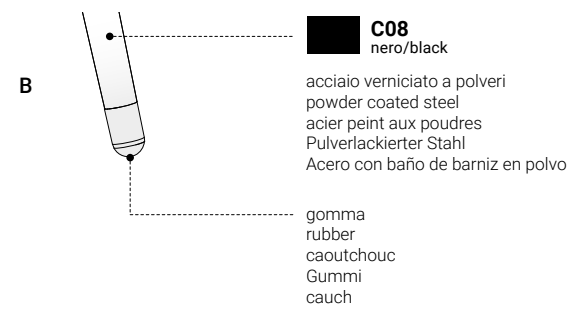
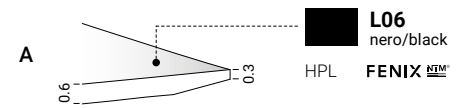
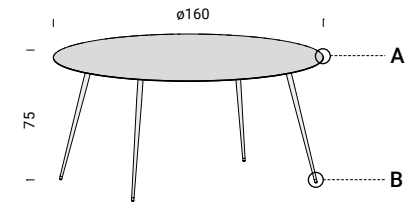

collection info  
pg. 134





**spillo**  
SP21

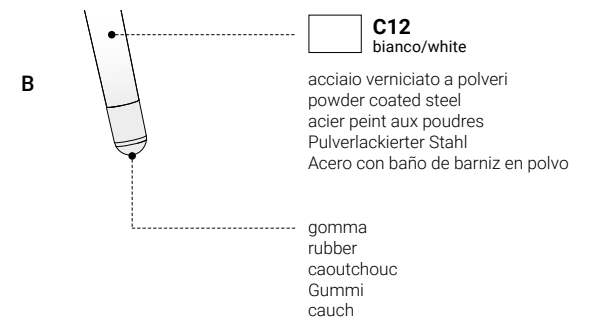
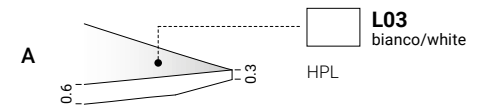
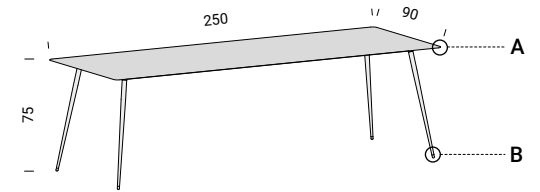

collection info  
pg. 134



# spillo

SP05

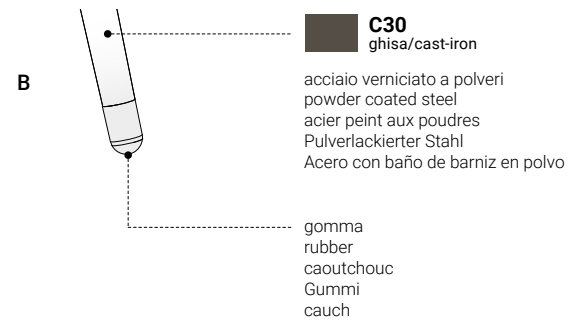
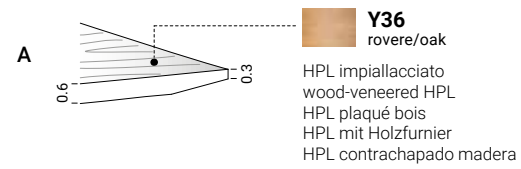
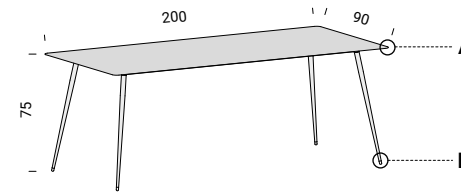

collection info  
pg. 134





**spillo**  
SP20

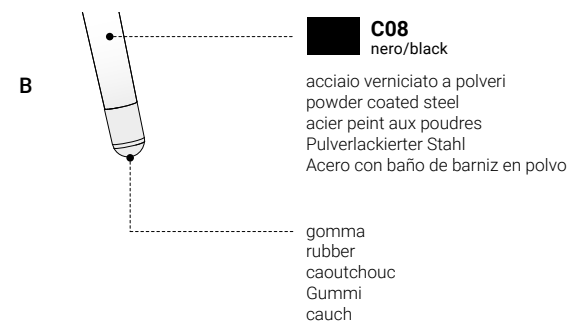
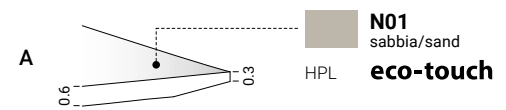
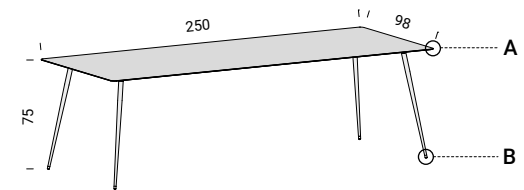

collection info  
pg. 134





**spillo**  
SP25

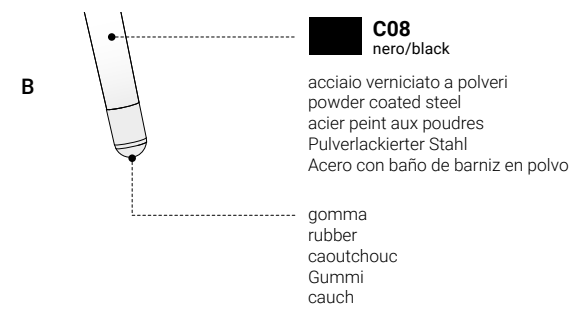
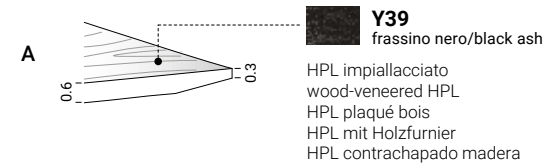
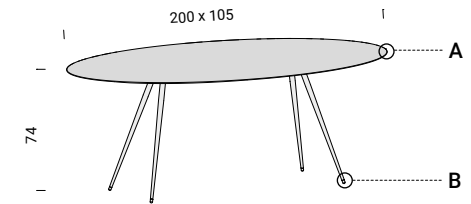

collection info  
pg. 134



**spillo**  
SP03

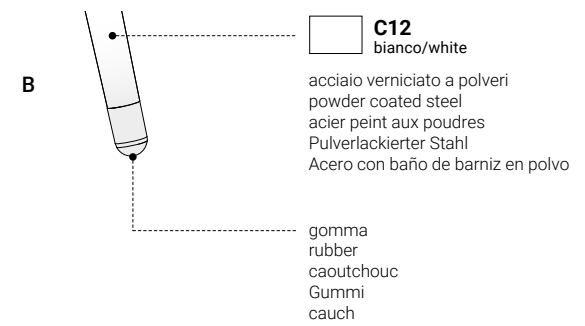
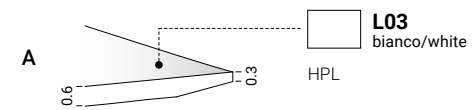
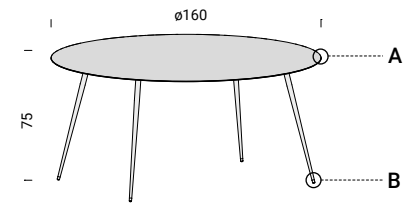

collection info  
pg. 134





**spillo**  
SP19

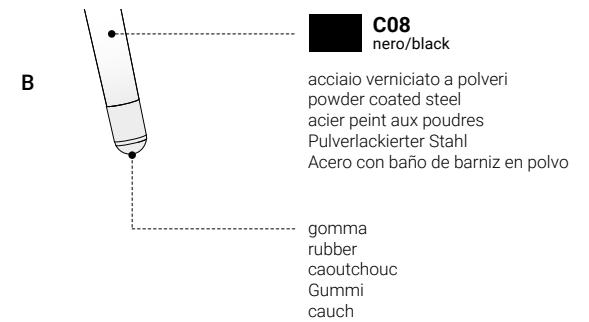
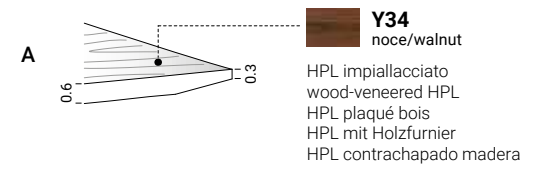
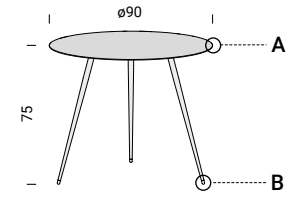

collection info  
pg. 134





## spillo

SP22

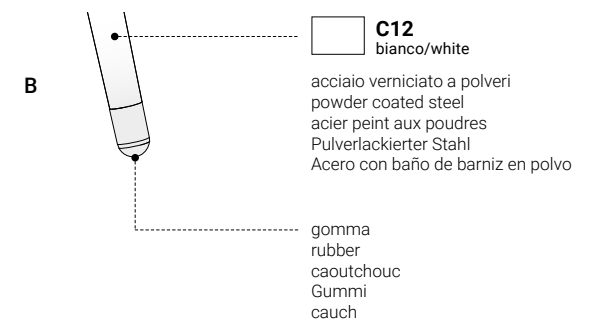
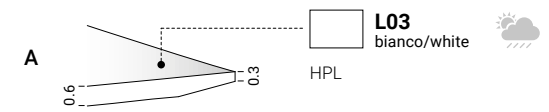
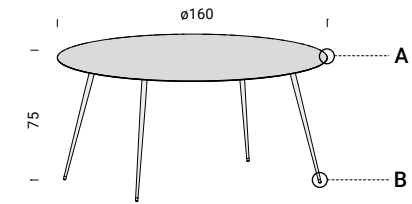

collection info  
pg. 134





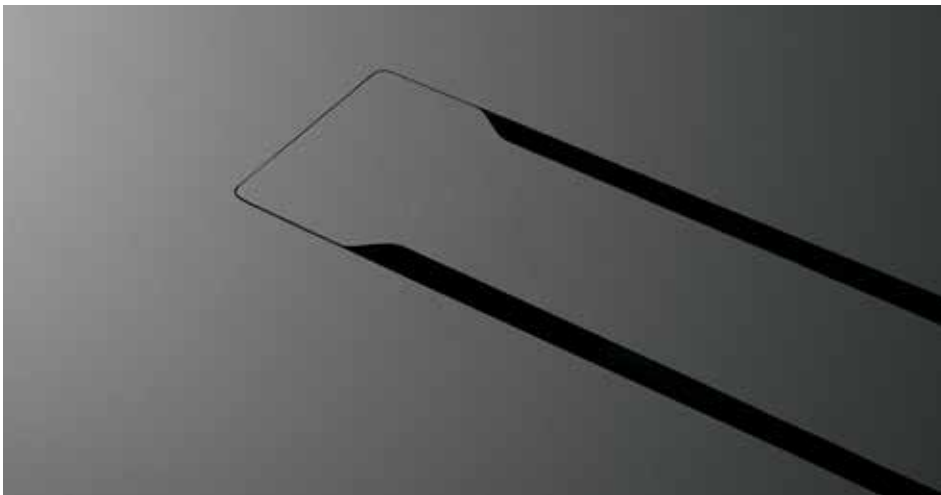

**spillo**  
SP04

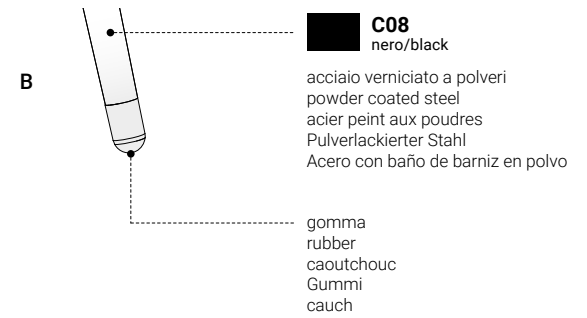
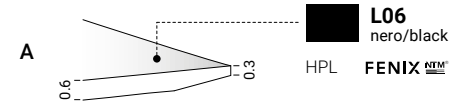
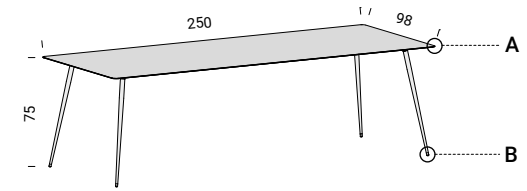

collection info  
pg. 134





## spillo SP26

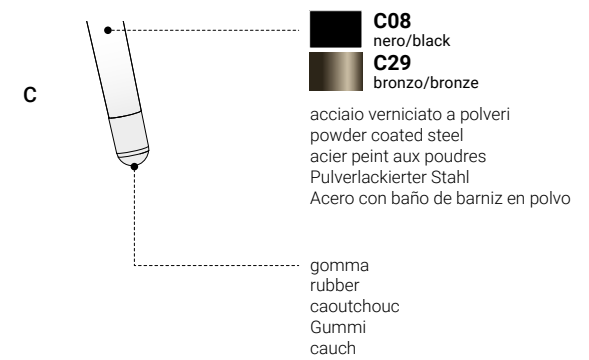
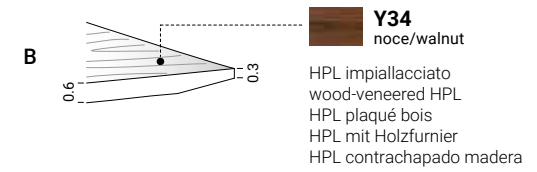
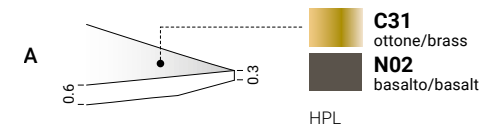
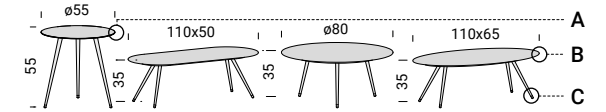

collection info  
pg. 134



# sintesi

**Semplicità costruttiva ed essenza dei materiali danno vita al tavolo allungabile "sintesi". Il telaio è in acciaio per consentire sezioni ribassate e mantenere performance di allungo sino a 300 cm. Il top è in HPL e i componenti interni sono in alluminio, ottone e acciaio inox, ciò rende compatibile il tavolo anche in outdoor.**

Simple construction and the essence of materials bringing a "Sintesi" extendable table to life. The steel frame allows for lowered sections and maintains performance up to a length of 300 cm. The top is in HPL and the inner parts are in aluminium, brass and stainless steel, making the table compact for outdoor use.

La simplicité de construction et l'essence des matériaux donnent le jour à la table à rallonges "sintesi". La structure est en acier pour permettre des sections surbaissées et maintenir une performance d'allongement jusqu'à 300 cm. Le plateau est en HPL et les composants internes sont en aluminium, laiton et acier inox, ce qui rend la table compatible pour utilisation également en extérieur.

Die einfache Konstruktion und das Wesentliche der Materialien sind kennzeichnend für den ausziehbaren Tisch „sintesi“. Der Rahmen ist aus Stahl, um abgeflachte Querschnitte und Längen von max. 300 cm zu ermöglichen. Das Abschlussbord ist aus HPL und die Innenteile sind aus Aluminium, Messing und Edelstahl, dadurch ist der Tisch auch für Outdoor geeignet.

Su construcción sencilla y la esencia de sus materiales dan vida a la mesa extensible "Sintesi". El bastidor es de acero para permitir secciones rebajadas y mantener su capacidad de extensión hasta 300 cm. El sobre es de HPL y los componentes interiores son de aluminio, latón y acero inoxidable, lo que hace que la mesa también se pueda usar en el exterior.



possibilità di affiancamento / possibility to place side by side / possibilité d'association / Aufstellung nebeneinander möglich / posibilidad de colocarse uno al lado del otro

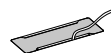

passacavo disponibile per tutti i top / cable gland available for all tops / passe-câble disponible pour tous les plateaux / Kabeldurchlass für alle Abschlussborde verfügbar / pasacables disponible para todos los sobres



iroko outdoor trattato ad olio 100% vegetale / Iroko outdoor treated with 100% vegetable oil / Iroko outdoor traité à l'huile 100% végétale / Iroko Outdoor behandelt mit 100% pflanzlichem Öl / Iroko para exteriores, tratado con aceite 100% vegetal

## materiali / materials



legno massiccio  
solid wood  
bois massif  
Massivholz  
madera maciza



HPL+legno  
HPL+wood  
HPL+bois  
HPL+Holz  
HPL+madera



HPL



acciaio  
steel  
acier  
Stahl  
acero

Le materie prime che costituiscono il sistema sintesi derivano da un processo di riutilizzo e sono a loro volta riciclabili.

The primary materials used in the system sintesi are sourced from a reuse process, and are in turn recyclable.

Les matières premières qui composent le système sintesi dérivent d'un processus de réutilisation et sont à leur tour recyclables.

Die Rohstoffe für das System sintesi entstammen einem Wiederverwertungsprozess und sind ihrerseits wiederum recyclebar.

Las materias primas que constituyen el sistema sintesi proceden de un proceso de reutilización y son, a su vez, reciclables.



**tavoli fissi/ fixed tables / tables fixes / fester Tische / mesas fijas**

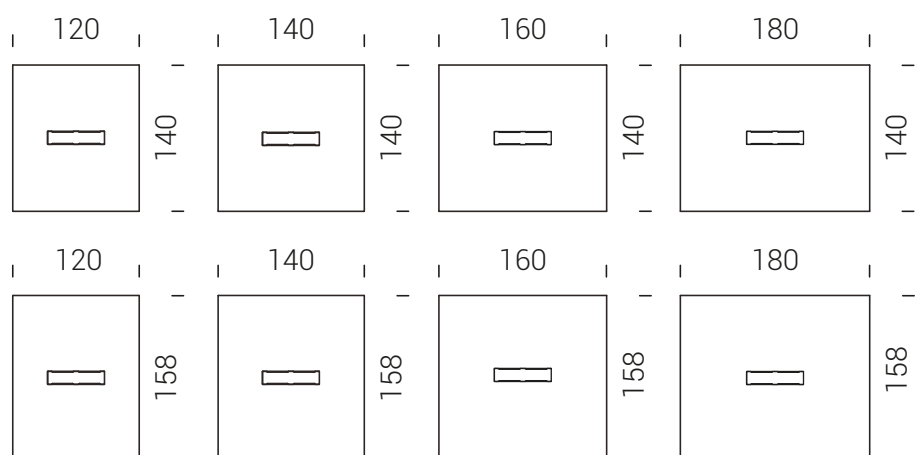
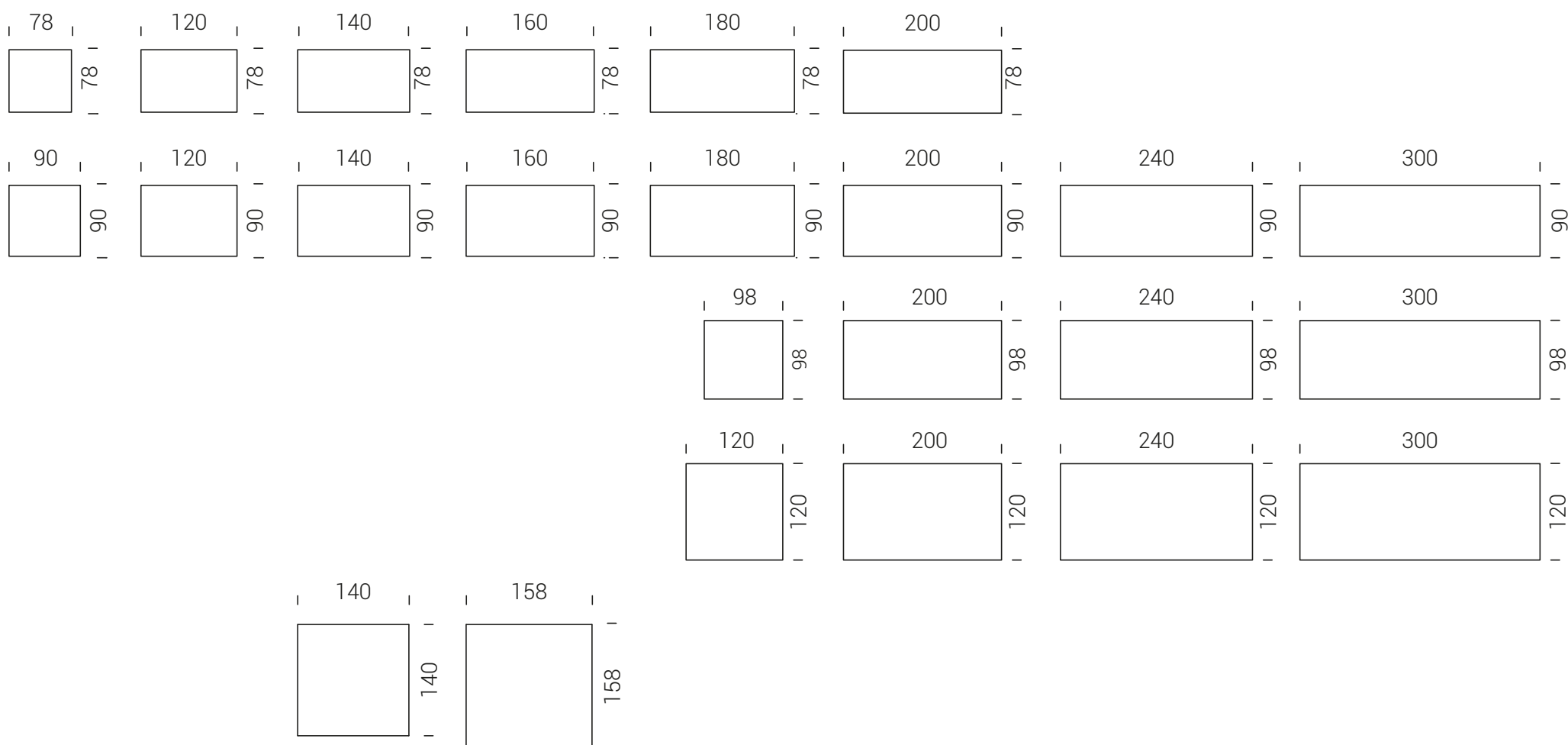
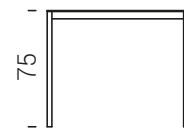

**tavoli e panche allungabili/ extendable tables and benches / tables et bancs extensibles / verlängerbarer Tische und Bänchen / mesas e bancos extensibles**

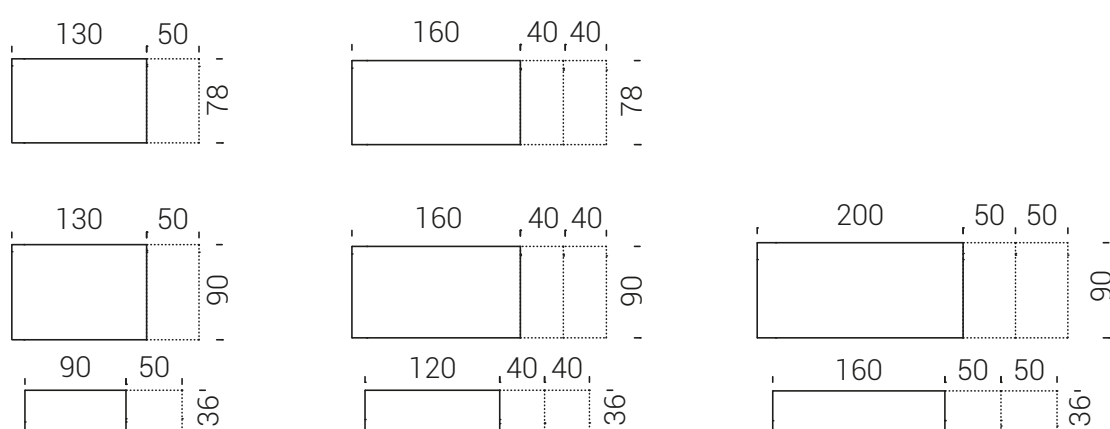
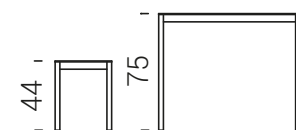

**panche fisse/ fixed benches / bancs fixes / fester Bänchen / bancos fijas**



**accessori / accessories / accessoires / Zubehör / accesorios**

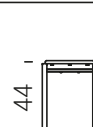

cuscinò / cushion  
coussin / Kissen  
cojín

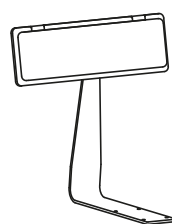

schienale / backrest  
dossier / Rücken  
respaldo

top tavolo / table top / plateaux de table / Tischplatte / plano de mesa

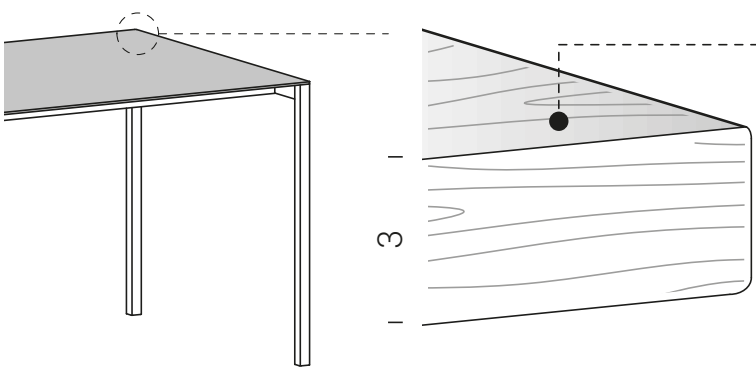

legno massiccio  
solid wood  
bois massif  
Massivholz  
madera maciza



**T01** rovere  
oak



**T02** noce  
walnut



**T03** iroko



**T04** iroko outdoor

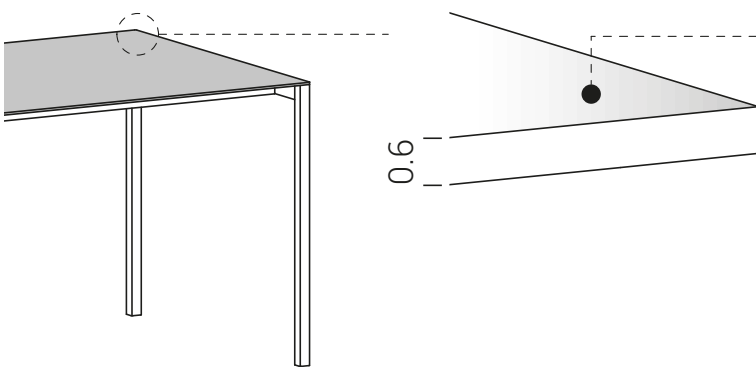

HPL



**L03** bianco  
white



Fenix®



**L08** grigio Londra  
London grey



**L06** nero  
black



HPL + legno  
wood  
bois  
Holz  
madera



**Y36** rovere  
oak



**Y34** noce  
walnut



**Y37** rovere affumicato  
smoked oak

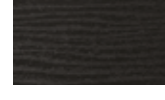

**Y39** frassino nero  
black arsh

HPL + metallo  
metal  
métal  
Metall  
metal



**C31** ottone  
brass



**C32** ottone scuro  
dark brass



**C35** inox  
inox



**C36** inox scuro  
dark inox



HPL + ecotouch



**N01** sabbia  
sand



**N02** basalto  
basalt

HPL + cemento  
concrete  
ciment  
zement  
cemento



**D01** bianco calce  
lime white



**D02** grigio Portland  
Portland grey

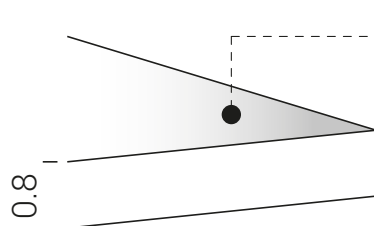

calcestruzzo  
beton  
béton  
Beton  
hormigón



**H01** quarzo  
quartz



**H02** arenaria  
brownstone



**H03** grafite  
graphite



HPL + pietra naturale  
natural stone  
pierre naturelle  
Naturstein  
piedra natural



**P01** grigio cenere  
ash grey



**P02** nero ardesia  
slate black



telaio / structure/ châssis / Gestell / bastidor

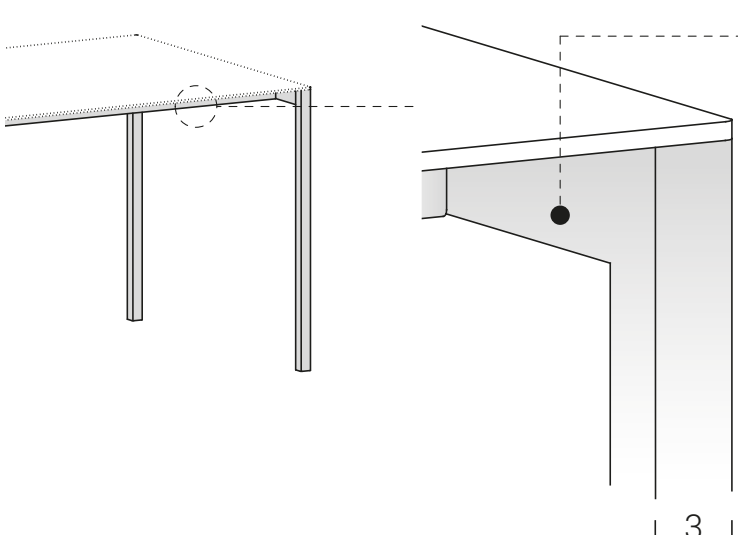

acciaio verniciato  
painted steel  
acier peint  
lackierter Stahl  
acero pintado



**C12** bianco  
white

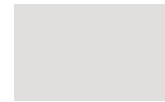

**C21** seta  
silk



**C23** corda  
ecru



**C30** ghisa  
cast-iron



**C14** antracite  
anthracite



**C08** nero  
black



**C18** verde  
green



**C26** corten  
corten



**C29** bronzo  
bronze





**sintesi**  
ST01

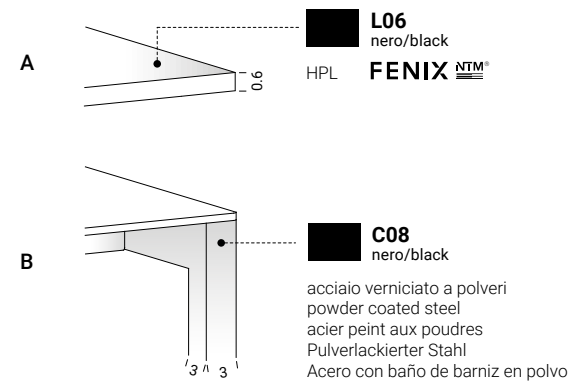
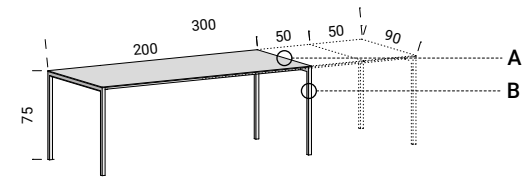

collection info  
pg. 152







## sintesi

ST02

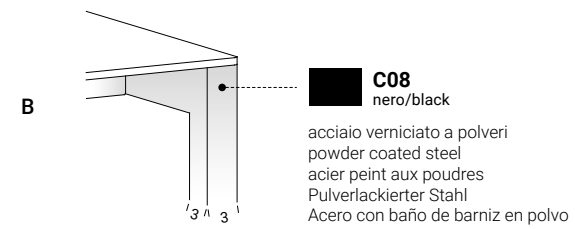
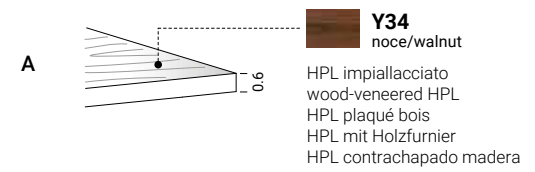
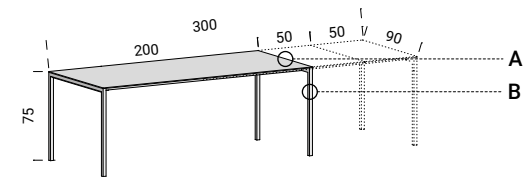

collection info  
pg. 152







## sintesi

ST06

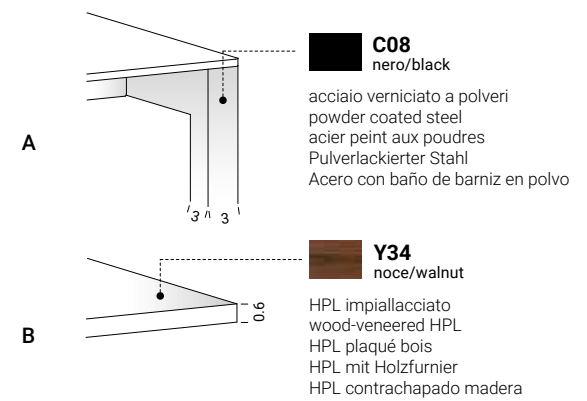
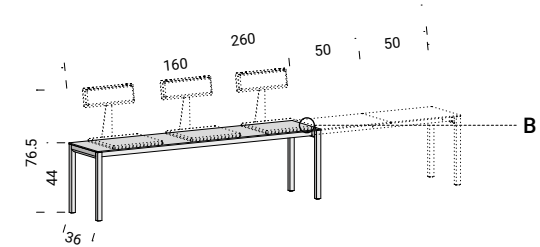
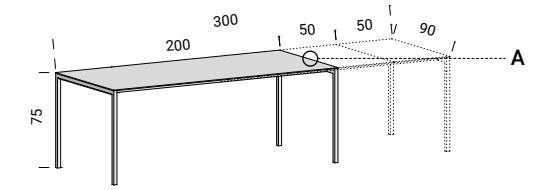

collection info  
pg. 152













**sintesi**  
ST03

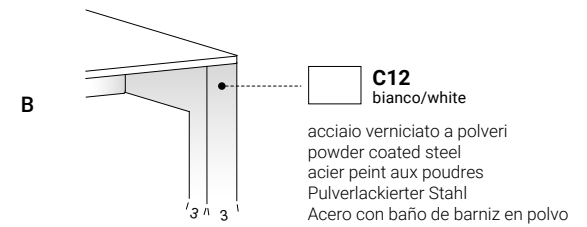
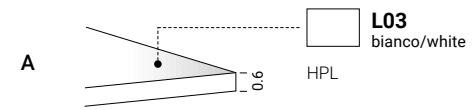
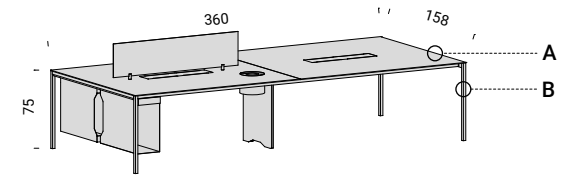

collection info  
pg. 152











## sintesi

ST04

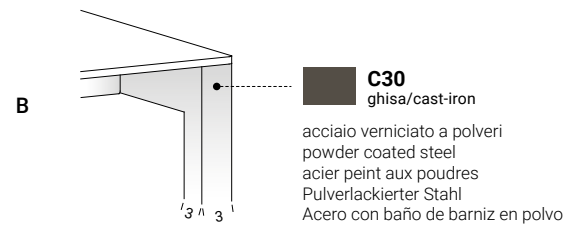
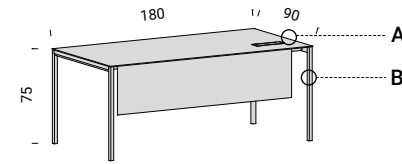

collection info  
pg. 152





## sintesi

ST05

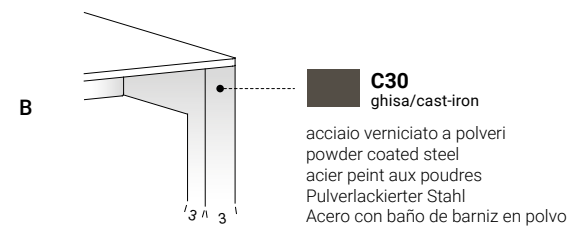
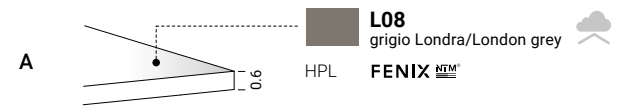
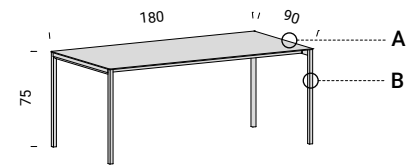

collection info  
pg. 152





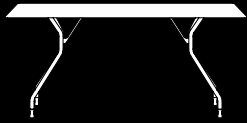

# T7

**Grazie alla tecnologia di piegatura tridimensionale dei profili è stato possibile realizzare un sistema tavoli che offre molteplici gradi di libertà. Il telaio leggero ma resistente supporta tavoli da 160 a 300cm di lunghezza, inoltre accoglie 5 tipologie di geometrie top e rende possibile anche la riduzione a misura.**

Thanks to the 3D profile bending technology, it has been possible to create a table system that provides multiple degrees of freedom. The light yet resistant frame supports tables between 160 and 300cm long; moreover, it can accommodate 5 types table top profiles and makes custom reduction possible.

Grâce à la technologie de pliage tridimensionnel des profils, il a été possible de réaliser un système de tables qui offre de nombreux niveaux de liberté. Le châssis léger, mais résistant, supporte des tables de 160 à 300 cm de longueur, en outre il accueille 5 typologies de géométries de plateaux et permet aussi la réduction sur mesure.

Dank eines technologisch ausgefeilten, dreidimensionalen Biegeverfahrens erhält man Profile für ein Tischsystem mit einem breiten Spektrum an freien Gestaltungsmöglichkeiten. Leichte, formstabile Gestelle tragen Tischplatten von 160 bis 300 cm Länge, in fünf verschiedenen Ausformungen und Größen, wobei auch die Verkürzung nach Maß vorgesehen ist.

Gracias a la tecnología de doblado tridimensional de los perfiles, se ha podido realizar un sistema de mesas que ofrece múltiples niveles de libertad. El bastidor ligero pero resistente, soporta mesas de 160 a 300cm de largo: además, cuenta con 5 tipos de geometrías para la encimera y también permite la reducción a medida.



disponibili riduzioni a misura / tailor-made reduction available / disponibles réductions sur mesure / Verkleinerung nach Kundenwunsch / Disponibles reducciones a medida

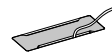

passacavo disponibile per tutti i top / cable gland available for all topspasse-câble disponible pour tous les plateaux / Kabeldurchlass für alle Abschlussborde verfügbar / pasacables disponible para todos los sobres



iroko outdoor trattato ad olio 100% vegetale / Iroko outdoor treated with 100% vegetable oil / Iroko outdoor traité à l'huile 100% végétale / Iroko Outdoor behandelt mit 100% pflanzlichem Öl / Iroko para exteriores, tratado con aceite 100% vegetal

## materiali / materials



legno massiccio  
solid wood bois  
massif Massivholz  
madera maciza

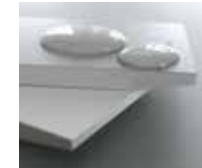

HPL



HPL+legno  
HPL+wood  
HPL+bois  
HPL+Holz  
HPL+madera



acciaio  
steel  
acier  
Stahl  
acero

Le materie prime che costituiscono il sistema T7 derivano da un processo di riutilizzo e sono a loro volta riciclabili.

The primary materials used in the system T7 are sourced from a reuse process, and are in turn recyclable.

Les matières premières qui composent le système T7 dérivent d'un processus de réutilisation et sont à leur tour recyclables.

Die Rohstoffe für das System T7 entstammen einem Wiederverwertungsprozess und sind ihrerseits wiederum recyclebar.

Las materias primas que constituyen el sistema T7 proceden de un proceso de reutilización y son, a su vez, reciclables.

tavoli / tables / tables / Tische / mesas

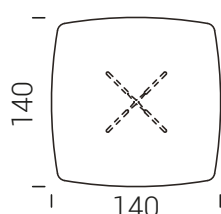
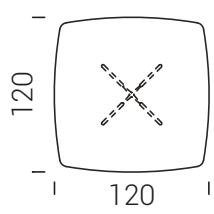
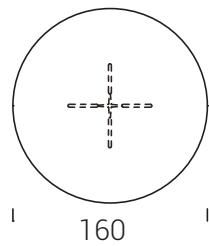
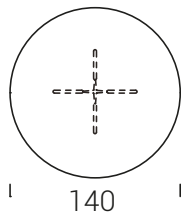
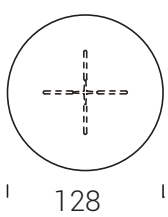
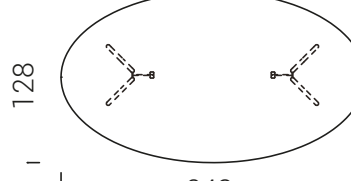
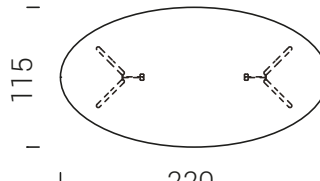
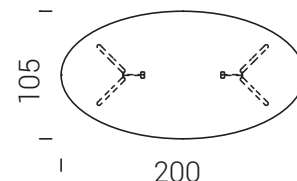
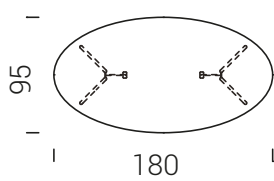
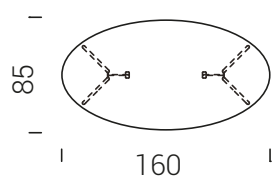
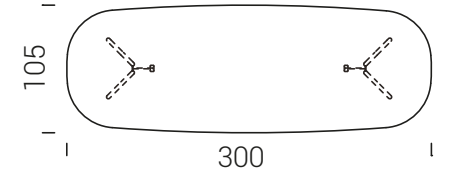
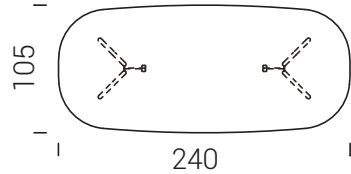
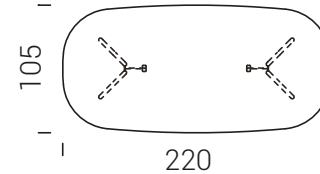
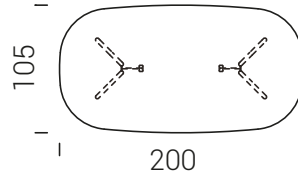
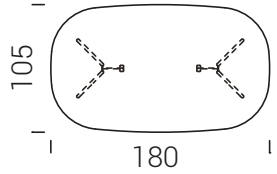
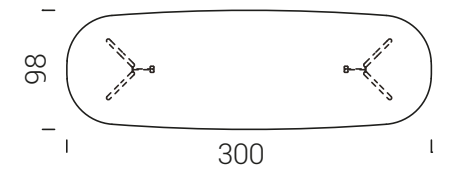
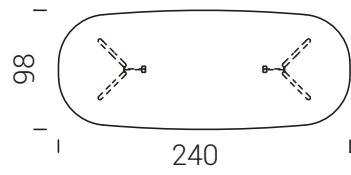
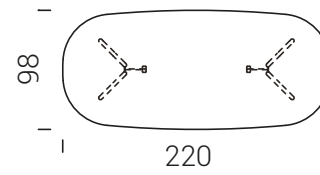
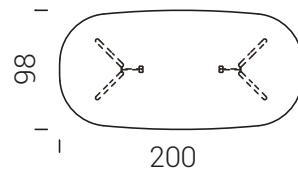
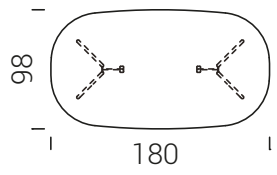
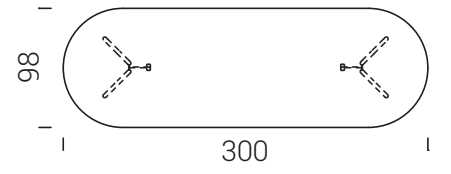
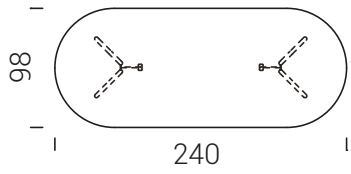
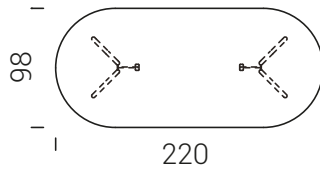
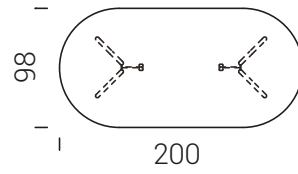
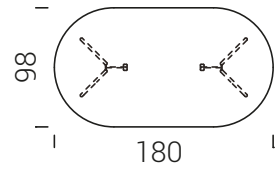
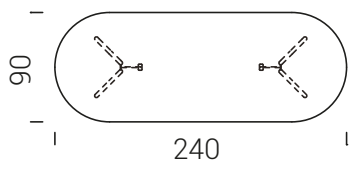
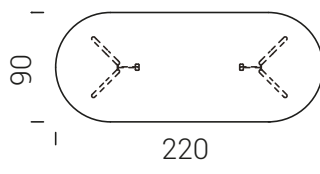
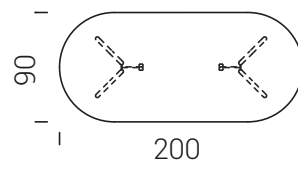
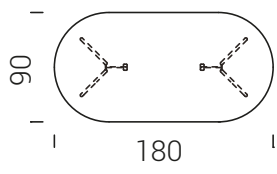
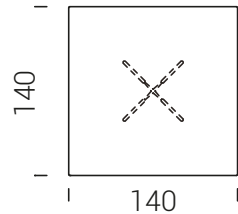
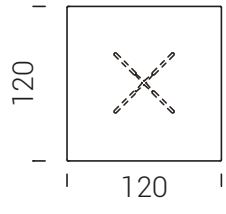
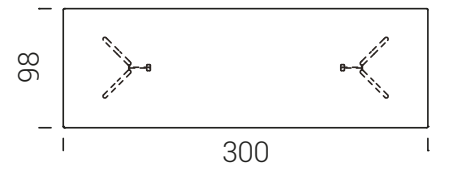
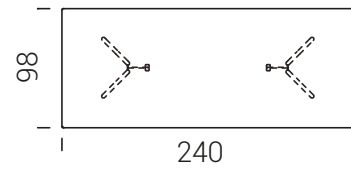
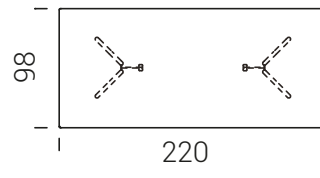
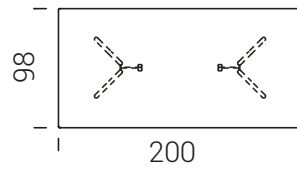
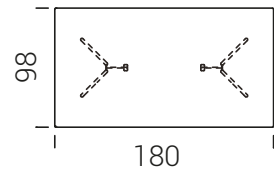
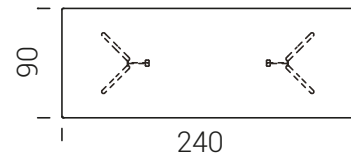
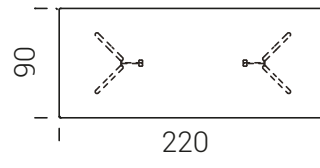
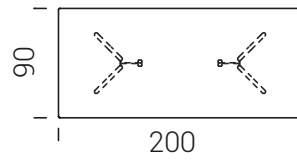
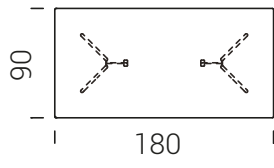
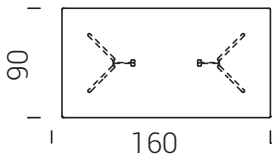

top tavolo / table top / plateaux de table / Tischplatte / plano de mesa

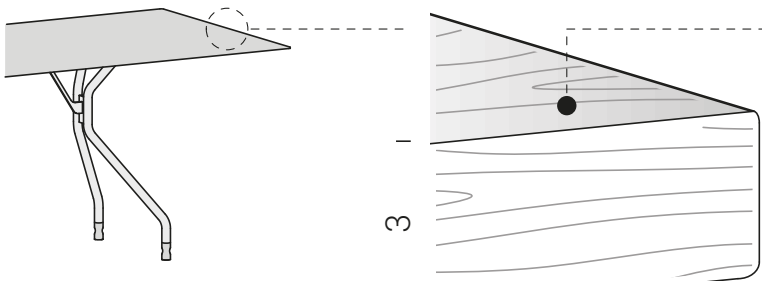

legno massiccio  
solid wood  
bois massif  
Massivholz  
madera maciza



**T01** rovere  
oak



**T02** noce  
walnut



**T03** iroko



**T04** iroko outdoor

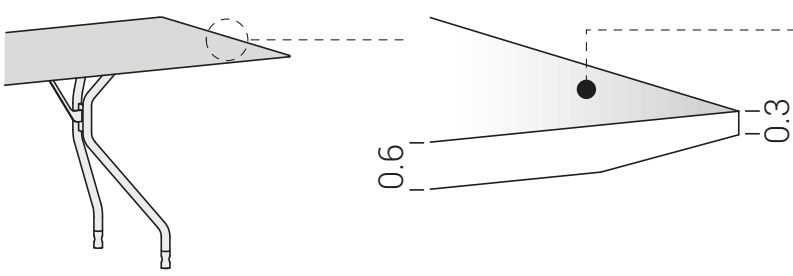

HPL



**L03** bianco  
white



Fenix®



**L08** grigio Londra  
London grey



**L06** nero  
black



HPL + legno  
wood  
bois  
Holz  
madera



**Y36** rovere  
oak



**Y34** noce  
walnut



**Y37** rovere affumicato  
smoked oak

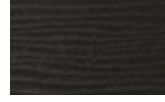

**Y39** frassino nero  
black ash

HPL + metallo  
metal  
métal  
Metall  
metal



**C31** ottone  
brass



**C32** ottone scuro  
dark brass



**C35** inox  
inox



**C36** inox scuro  
dark inox



HPL + ecotouch



**N01** sabbia  
sand



**N02** basalto  
basalt

HPL + cemento  
concrete  
ciment  
zement  
cemento



**D01** bianco calce  
lime white



**D02** grigio Portland  
Portland grey

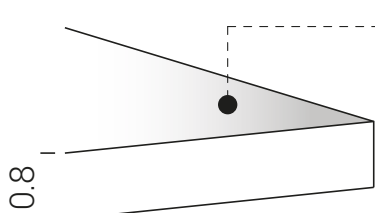

calcestruzzo  
beton  
béton  
Beton  
hormigón



**H01** quarzo  
quartz



**H02** arenaria  
brownstone



**H03** grafite  
graphite



HPL + pietra naturale  
natural stone  
pierre naturelle  
Naturstein  
piedra natural



**P01** grigio cenere  
ash grey



**P02** nero ardesia  
slate black



telaio / structure/ châssis / Gestell / bastidor

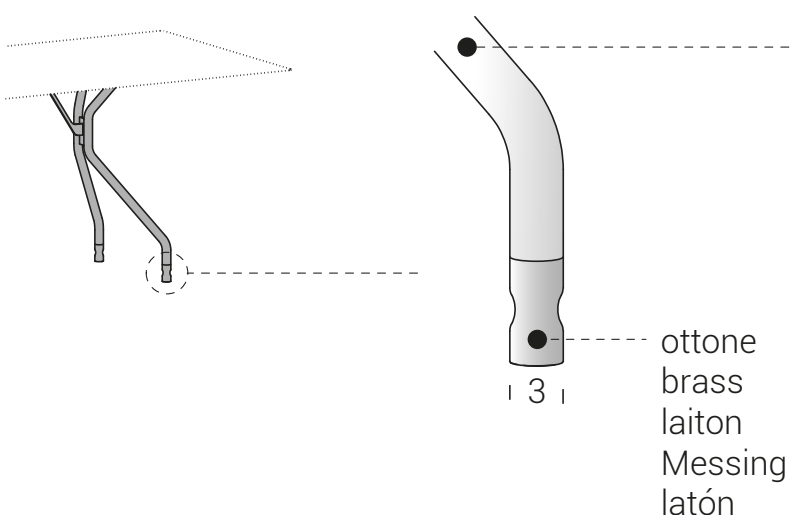

acciaio verniciato  
painted steel  
acier peint  
lackierter Stahl  
acero pintado



**C12** bianco  
white



**C21** seta  
silk



**C23** corda  
ecru



**C30** ghisa  
cast-iron



**C14** antracite  
anthracite



**C08** nero  
black



**C18** verde  
green



**C26** corten  
corten



**C29** bronzo  
bronze







## T7

T701

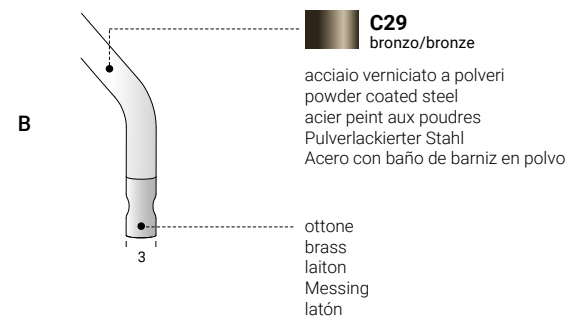
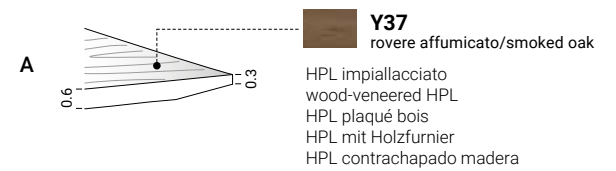
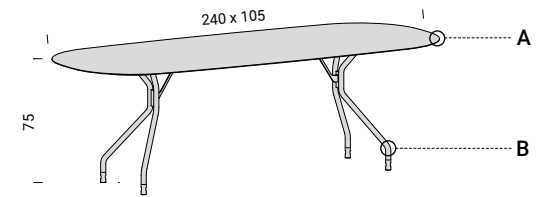

collection info  
pg. 168







**T7**  
T702

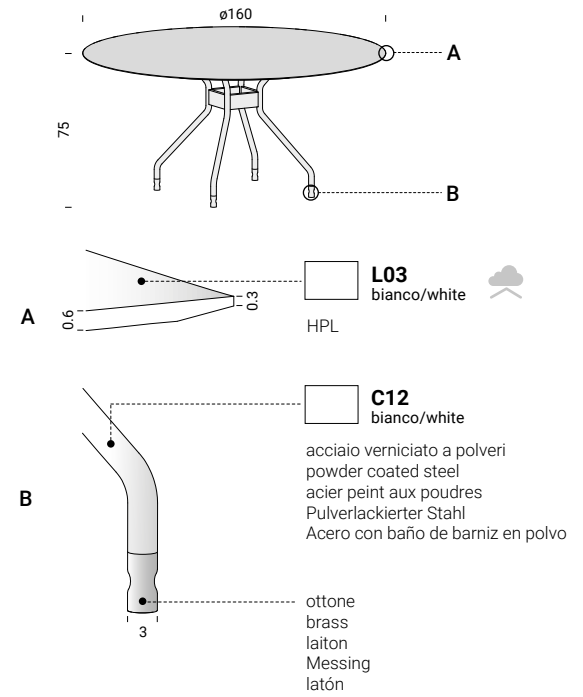

collection info  
pg. 168



# T8

**Un progetto di Le Corbusier del 1928 ha ispirato il design di questo sistema tavoli. I nuovi materiali hanno consentito un ridisegno all'insegna della leggerezza e di una grande libertà di configurazione. E' una collezione di tavoli e panche disponibili nella versione fissa e allungabile.**

A 1928 Le Corbusier project inspired the design of this table system. New materials have enabled a re-designing of this project in pursuit of lightness along with a great freedom of configuration. This is a collection of tables and benches available in both fixed and extendable versions.

Un projet de Le Corbusier de 1928 a inspiré le design de ce système de tables. Les nouveaux matériaux ont permis de le redessiner à l'enseigne de la légèreté et d'une grande liberté de configuration. C'est une collection de tables et de bancs disponibles dans la version fixe et extensible.

Ein Entwurf von Le Corbusier aus dem Jahr 1928 diente als Anregung für das Design dieses Tischsystems. Innovative Materialien prägen das aktualisierte Konzept, bei dem Leichtigkeit und eine große Gestaltungsfreiheit im Vordergrund stehen. Eine Kollektion von Tischen und Bänken, die als feste oder ausziehbare Version zur Verfügung steht.

Un diseño de Le Corbusier de 1928, inspiró el diseño de este sistema de mesas. Los nuevos materiales han permitido realizar un nuevo diseño sobre la base del antiguo, caracterizado por ligereza y gran libertad de configuración. Es una colección de mesas y banquetos disponibles en la versión fija y extensible.



disponibili riduzioni a misura / tailor-made reduction available / disponibles réductions sur mesure / Verkleinerung nach Kundenwunsch / Disponibles reducciones a medida

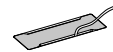

passacavo disponibile per tutti i top / cable gland available for all tops / passe-câble disponible pour tous les plateaux / Kabeldurchlass für alle Abschlussborde verfügbar / pasacables disponible para todos los sobres



iroko outdoor trattato ad olio 100% vegetale / Iroko outdoor treated with 100% vegetable oil / Iroko outdoor traité à l'huile 100% végétale / Iroko Outdoor behandelt mit 100% pflanzlichem Öl / Iroko para exteriores, tratado con aceite 100% vegetal

## materiali / materials



legno massiccio  
solid wood bois  
massif Massivholz  
madera maciza

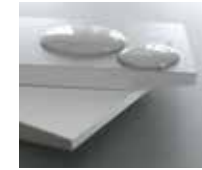

HPL



HPL+legno  
HPL+wood  
HPL+bois  
HPL+Holz  
HPL+madera



acciaio  
steel  
acier  
Stahl  
acero

Le materie prime che costituiscono il sistema T8 derivano da un processo di riutilizzo e sono a loro volta riciclabili.

The primary materials used in the system T8 are sourced from a reuse process, and are in turn recyclable.

Les matières premières qui composent le système T8 dérivent d'un processus de réutilisation et sont à leur tour recyclables.

Die Rohstoffe für das System T8 entstammen einem Wiederverwertungsprozess und sind ihrerseits wiederum recyclebar.

Las materias primas que constituyen el sistema T8 proceden de un proceso de reutilización y son, a su vez, reciclables.



**tavoli / tables / tables / Tische / mesas**

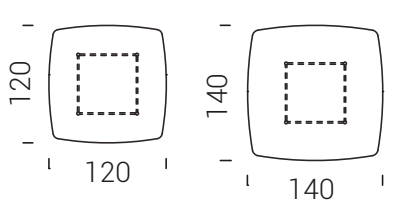
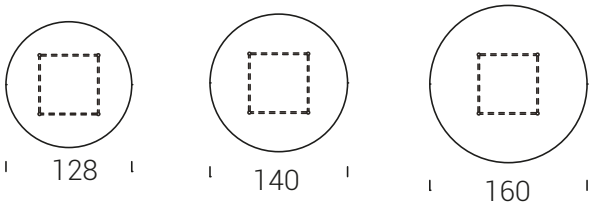
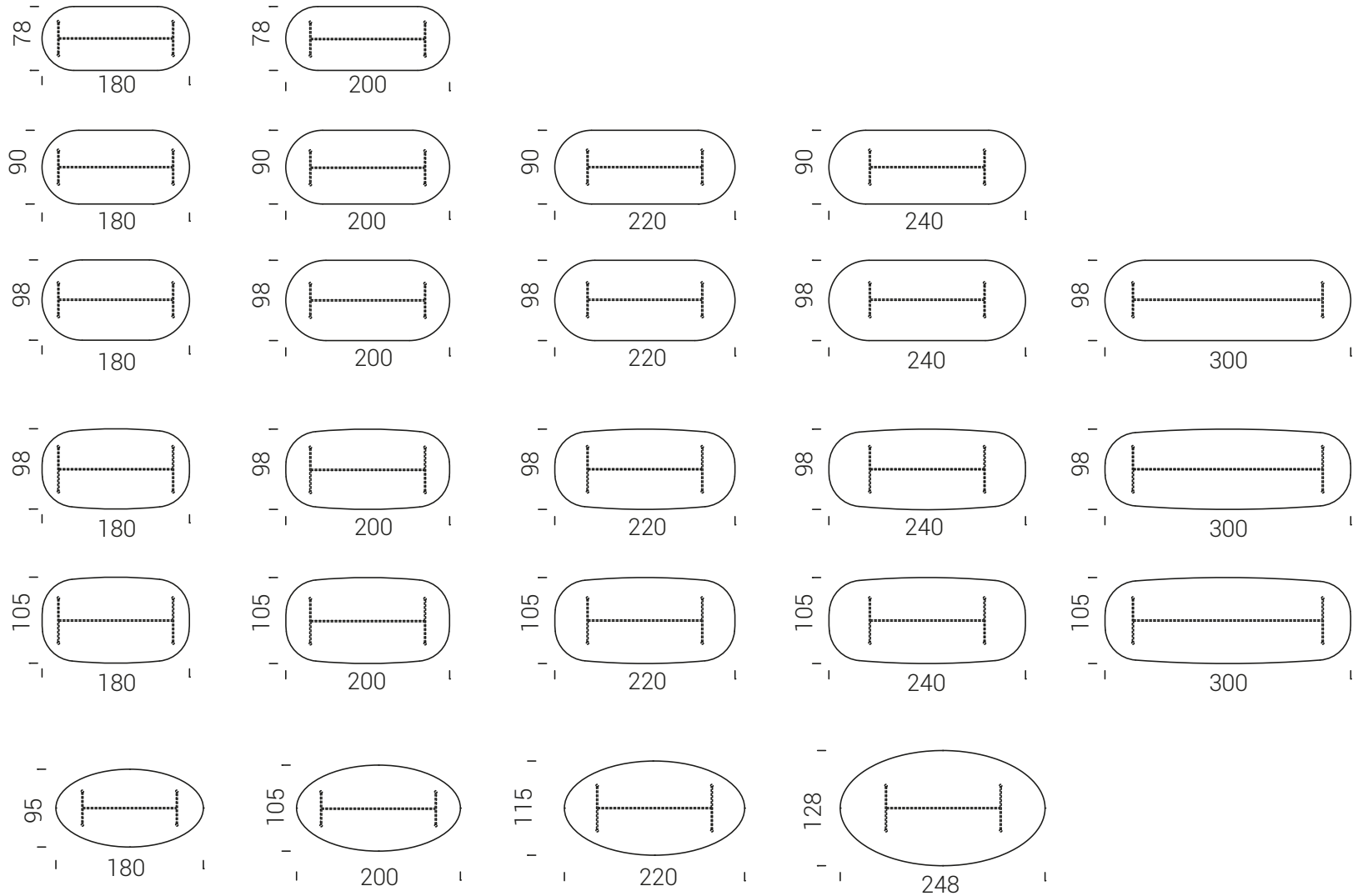
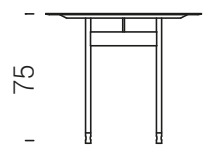
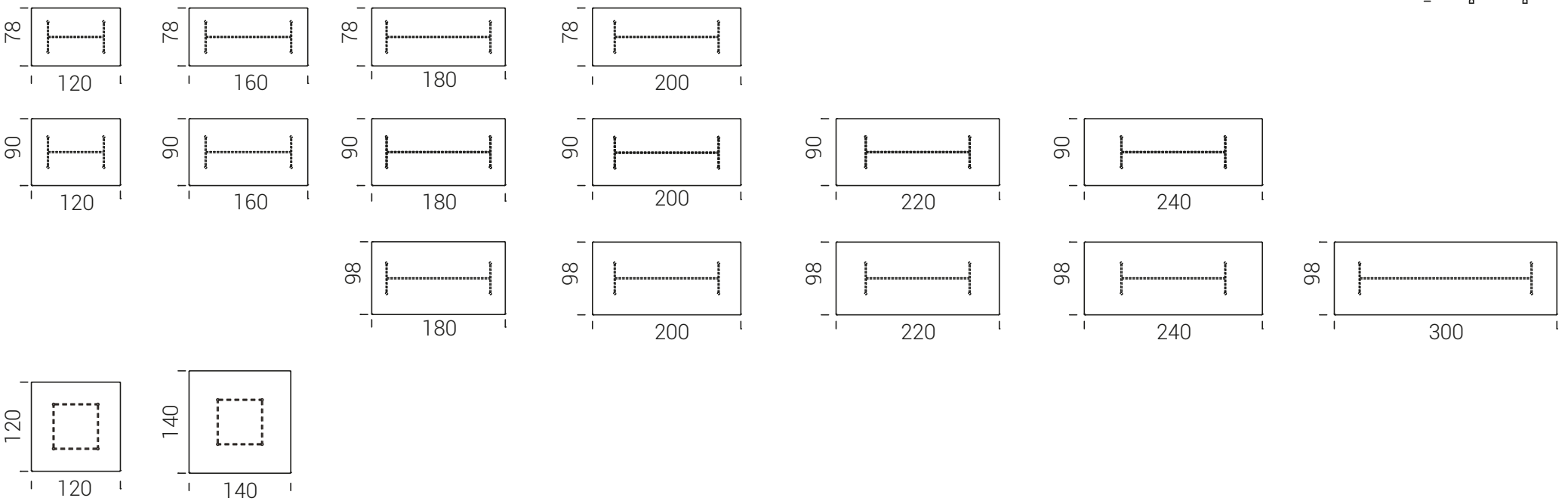

**tavoli e panche allungabili/ extendable tables and benches / tables et bancs extensibles  
verlängerbarer Tische und Bänchen / mesas y bancos extensibles**

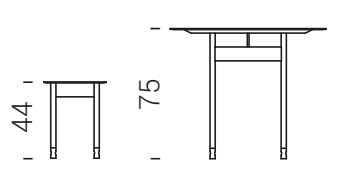
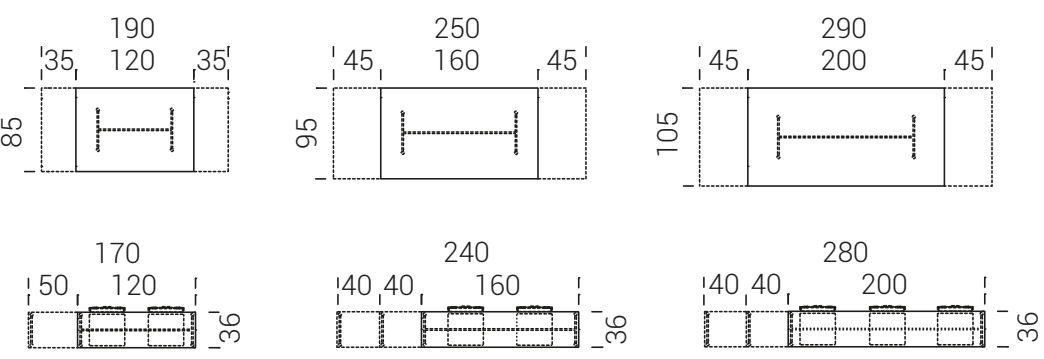

**panche fisse/ fixed benches / bancs fixes / fester Bänchen / bancos fijas**

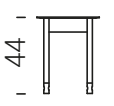
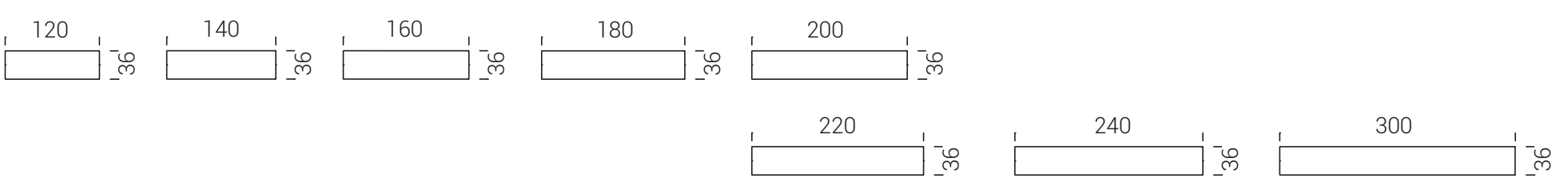

**tavoli e panche per esterno / outdoor tables and benches / tables et bancs pour l'extérieur  
Tische und Bänke für draußen / mesas y bancos para exterior**

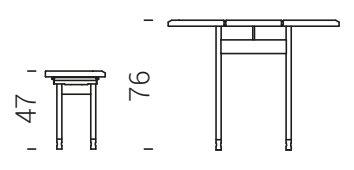
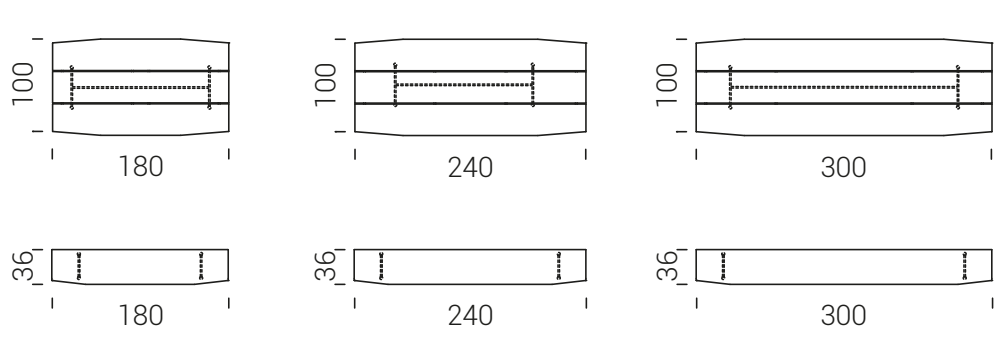

top tavolo / table top / plateaux de table / Tischplatte / plano de mesa

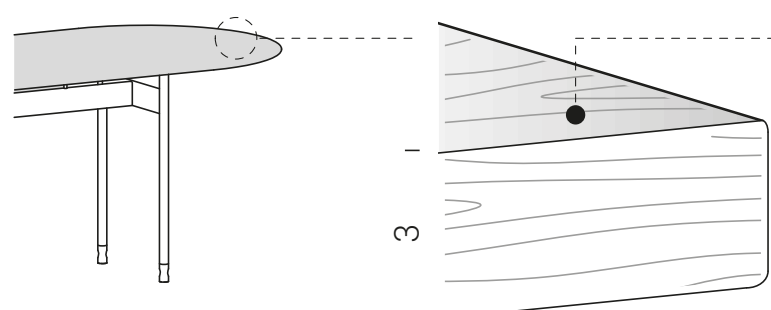

legno massiccio  
solid wood  
bois massif  
Massivholz  
madera maciza



**T01** rovere  
oak



**T02** noce  
walnut



**T03** iroko



**T04** iroko outdoor

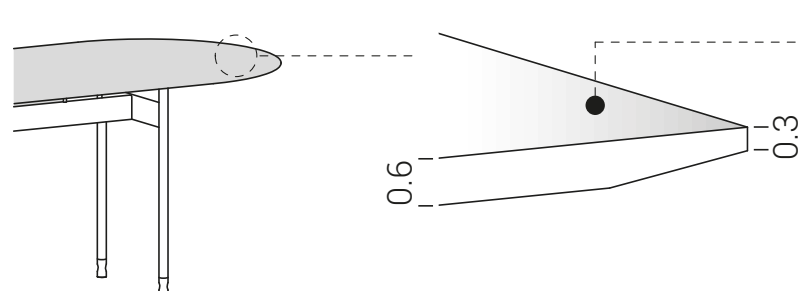

HPL



**L03** bianco  
white



Fenix®



**L08** grigio Londra  
London grey



**L06** nero  
black



HPL + legno  
wood  
bois  
Holz  
madera



**Y36** rovere  
oak



**Y34** noce  
walnut



**Y37** rovere affumicato  
smoked oak



**Y39** frassino nero  
black ash

HPL + metallo  
metal  
métal  
Metall  
metal



**C31** ottone  
brass



**C32** ottone scuro  
dark brass



**C35** inox  
inox



**C36** inox scuro  
dark inox



HPL + ecotouch



**N01** sabbia  
sand



**N02** basalto  
basalt

HPL + cemento  
concrete  
ciment  
zement  
cemento



**D01** bianco calce  
lime white



**D02** grigio Portland  
Portland grey

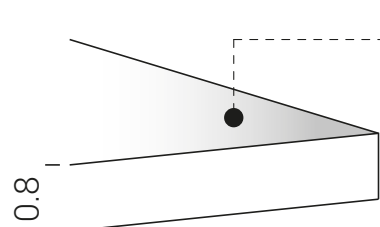

calcestruzzo  
beton  
béton  
Beton  
hormigón



**H01** quarzo  
quartz



**H02** arenaria  
brownstone



**H03** grafite  
graphite



HPL + pietra naturale  
natural stone  
pierre naturelle  
Naturstein  
piedra natural



**P01** grigio cenere  
ash grey



**P02** nero ardesia  
slate black



telaio / structure/ châssis / Gestell / bastidor

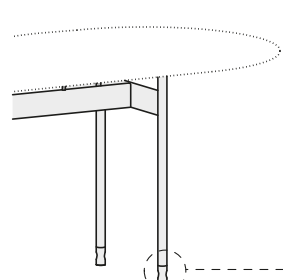

ottone  
brass  
laiton  
Messing  
latón

acciaio verniciato  
painted steel  
acier peint  
lackierter Stahl  
acero pintado



**C12** bianco  
white



**C21** seta  
silk



**C23** corda  
ecru



**C30** ghisa  
cast-iron



**C14** antracite  
anthracite



**C08** nero  
black



**C18** verde  
green



**C26** corten  
corten



**C29** bronzo  
bronze



uso in esterno riparato  
sheltered outdoor use





**T8**  
T801

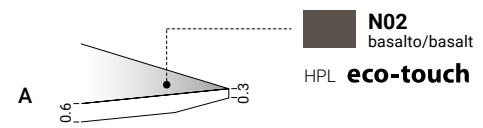
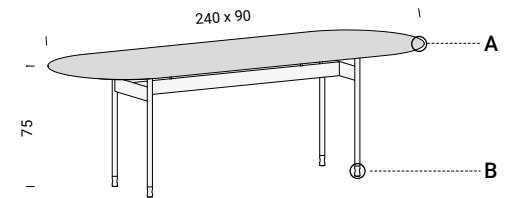

**N02**  
basalto/basalt  
HPL **eco-touch**

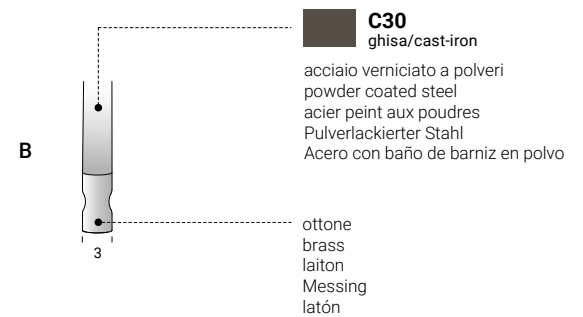

**C30**  
ghisa/cast-iron  
acciaio verniciato a polveri  
powder coated steel  
acier peint aux poudres  
Pulverlackierter Stahl  
Acero con baño de barniz en polvo

ottone  
brass  
laiton  
Messing  
latón

collection info  
pg. 174







**T8**  
T803

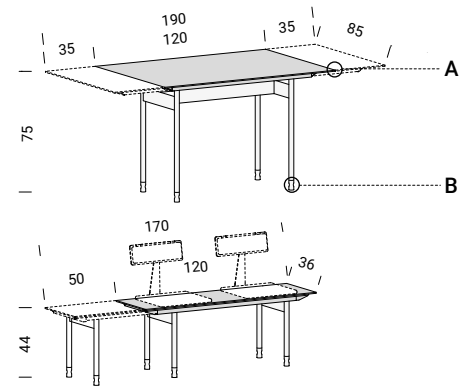

**A**

**Y39**  
frassino nero/black ash

legno massiccio  
solid wood  
bois massif  
Massivholz  
madera maciza

**B**

**C08**  
nero/black

acciaio verniciato a polveri  
powder coated steel  
acier peint aux poudres  
Pulverlackierter Stahl  
Acero con baño de barniz en polvo

ottone  
brass  
laiton  
Messing  
latón

collection info  
pg. 174











**T8**  
T804

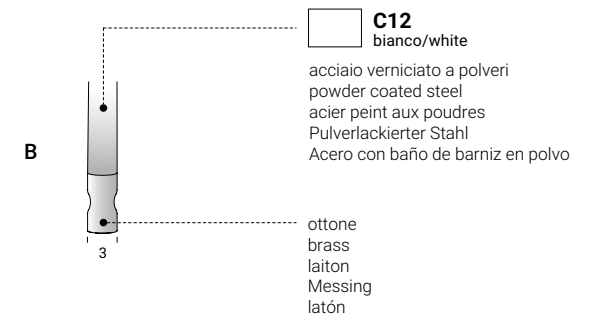
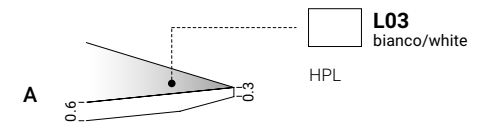
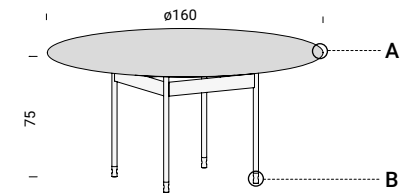

collection info  
pg. 174







**T8**  
T802

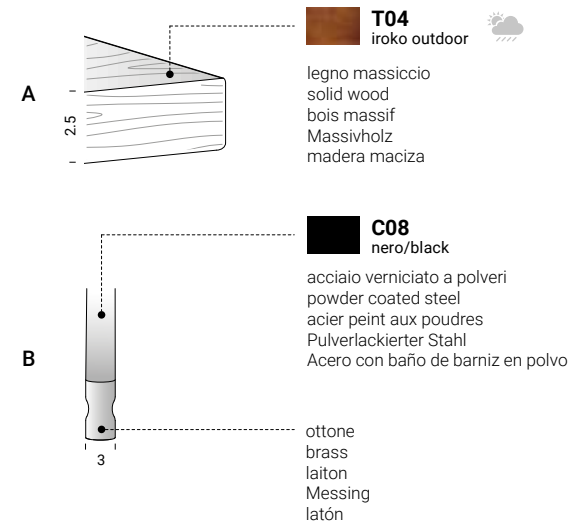
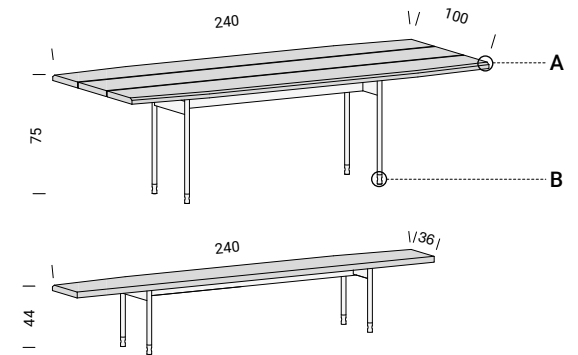

collection info  
pg. 174



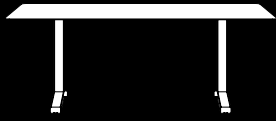

# IPE

**Una collezione progettata per costruire tavoli di grandi dimensioni, la sezione ad IPE in acciaio utilizzata per il supporto dei top tavoli conferisce grande rigidità e consente di nascondere i cavi di alimentazione di unità multimediali dal top alla parte inferiore del supporto. I top possono essere accostati per dare vita ad un sistema tavoli con dimensioni a progetto.**

This is a collection that has been designed in order to create large tables, the IPE section in steel used to support the table tops provides great sturdiness and allows the power cables from multimedia devices to be concealed from the top to the bottom of the support. The table tops can be combined in order to give life to a custom-sized table system.

Une collection conçue pour construire des tables de grandes dimensions, la section en IPE d'acier utilisée pour le support des plateaux de table fournit une grande rigidité et permet de cacher les câbles d'alimentation d'unités multimédias, du plateau à la partie inférieure du support. Les plateaux peuvent être combinés pour créer un système de tables avec des dimensions selon le projet.

Bei unserer Kollektion von großflächigen, stabilen Tischen werden IPE-Stahlprofile als Stütze für die Tischplatte verwendet, denn sie gewährleisten eine ausgezeichnete Standfestigkeit und ermöglichen zudem eine versteckte Kabelführung von multimedialen Geräten auf der Platte bis zum unteren Teil des Gestells. Die Platten können aneinandergeschoben und kombiniert werden, um ein beliebig großes Tischsystem zu kreieren.

Una colección diseñada para construir mesas de gran tamaño: el perfil IPE de acero utilizado para el soporte de las encimeras de las mesas, ofrece una rigidez considerable y permite ocultar los cables de alimentación de unidades multimedia desde la encimera hasta la parte inferior del soporte. Las encimeras pueden colocarse una al lado de la otra para generar un sistema de mesas con tamaños conformes a diseño.



disponibili riduzioni a misura / custom reductions available / réductions sur mesure disponibles / Verkürzungen auf Maß erhältlich / disponibles reducciones a medida

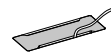

passacavo disponibile per tutti i top / cable gland available for all tops / passe-câble disponible pour tous les plateaux / Kabeldurchlass für alle Abschlussborde verfügbar / pasacables disponible para todos los sobres



iroko outdoor trattato ad olio 100% vegetale / iroko outdoor treated with 100% vegetable oil / iroko outdoor traité à l'huile 100% végétale / iroko Outdoor behandelt mit 100% pflanzlichem Öl / iroko para exteriores, tratado con aceite 100% vegetal



cassetto disponibile / drawer available / tiroir disponible / Schublade verfügbar / cajón disponible

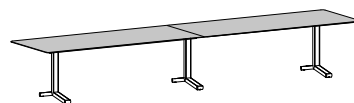

possibilità di affiancamento / possibility to place side by side / Possibilité d'association / aufstellung nebeneinander möglich / posibilidad de colocarse uno al lado del otro

## materiali / materials



legno massiccio  
solid wood bois  
massif Massivholz  
madera maciza

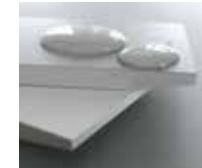

HPL



HPL+legno  
HPL+wood  
HPL+bois  
HPL+Holz  
HPL+madera



acciaio  
steel  
acier  
Stahl  
acero

Le materie prime che costituiscono il sistema IPE derivano da un processo di riutilizzo e sono a loro volta riciclabili.

The primary materials used in the system IPE are sourced from a reuse process, and are in turn recyclable.

Les matières premières qui composent le système IPE dérivent d'un processus de réutilisation et sont à leur tour recyclables.

Die Rohstoffe für das System IPE entstammen einem Wiederverwertungsprozess und sind ihrerseits wiederum recyclebar.

Las materias primas que constituyen el sistema IPE proceden de un proceso de reutilización y son, a su vez, reciclables.

**tavoli / tables / tables / Tische / mesas**

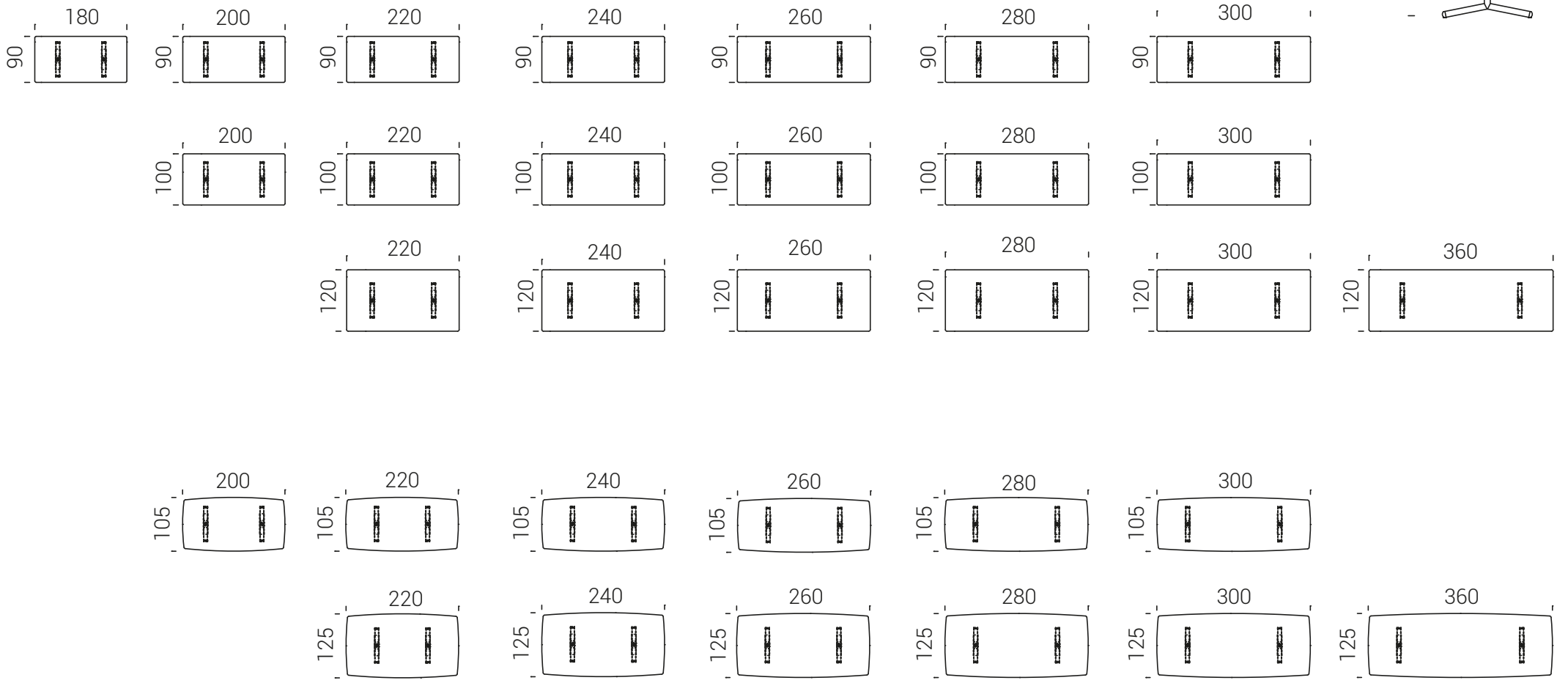

**tavoli affiancati rettangolari / rectangular side tables / tables associées rectangulaires  
nebeneinander gestellte rechteckige Tische  
mesas rectangulares para colocar unas al lado de las otras**

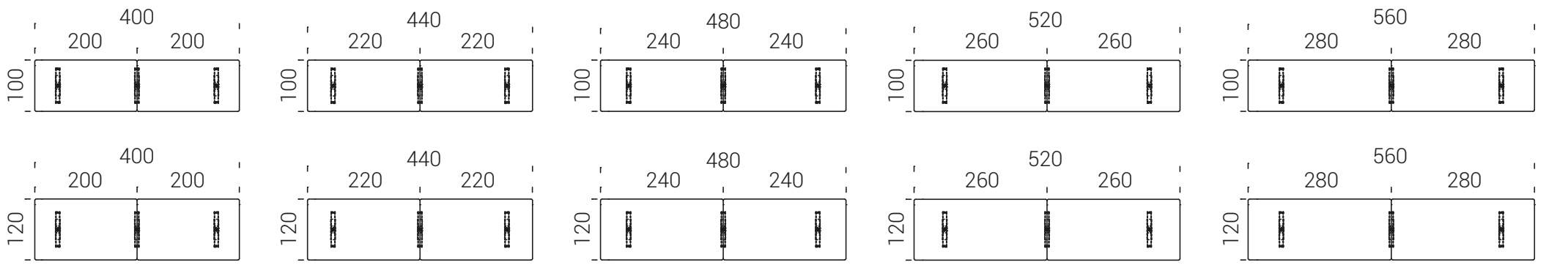

**tavoli affiancati a botte / barrel vault side tables / tables tonneau associées  
nebeneinander gestellte Weinfass-Tische / mesas de barril para colocar unas al lado de las otras**

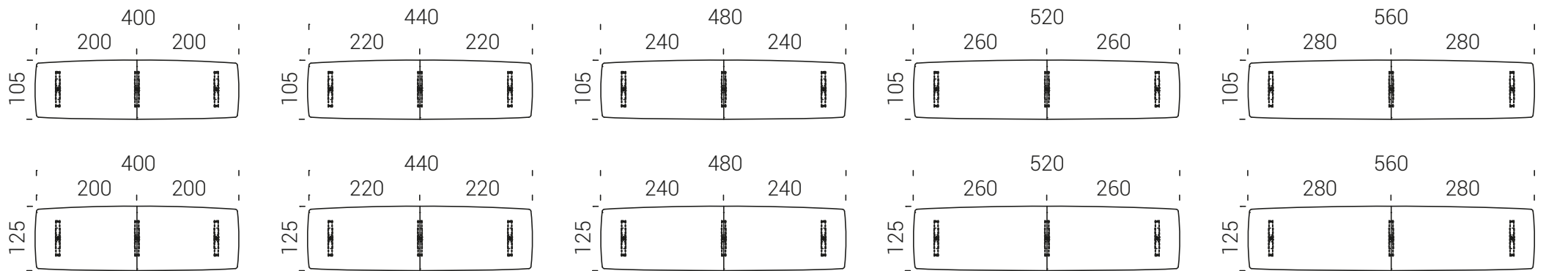

**tavoli in massello / solid wood tables / tables en bois massif  
Tische aus Massivholz / mesas de madera maciza**

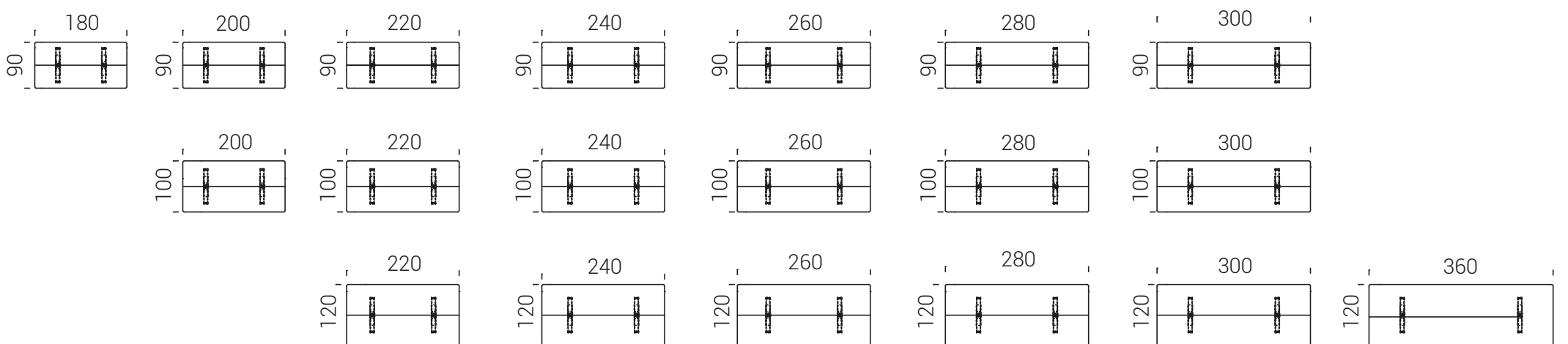

top tavolo / table top / plateaux de table / Tischplatte / plano de mesa

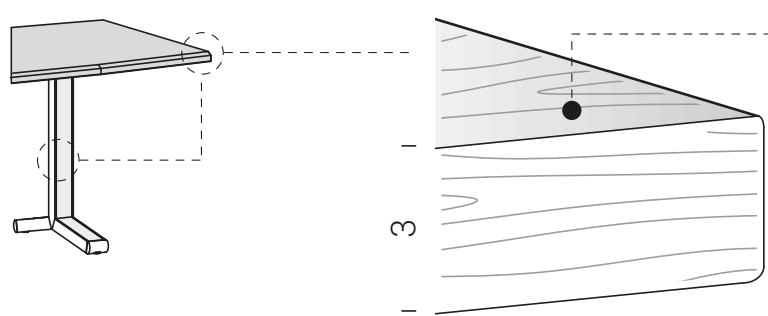

legno massiccio  
solid wood  
bois massif  
Massivholz  
madera maciza



**T01** rovere  
oak



**T02** noce  
walnut



**T03** iroko



**T04** iroko outdoor

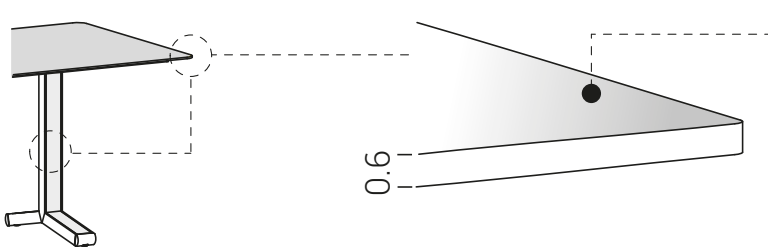

HPL



**L03** bianco  
white



Fenix®



**L08** grigio Londra  
London grey



**L06** nero  
black



HPL + legno  
wood  
bois  
Holz  
madera



**Y36** rovere  
oak



**Y34** noce  
walnut



**Y37** rovere affumicato  
smoked oak



**Y39** frassino nero  
black arsh

HPL + metallo  
metal  
métal  
Metall  
metal



**C31** ottone  
brass



**C32** ottone scuro  
dark brass



**C35** inox  
inox



**C36** inox scuro  
dark inox



HPL + ecotouch



**N01** sabbia  
sand



**N02** basalto  
basalt

HPL + cemento  
concrete  
ciment  
zement  
cemento



**D01** bianco calce  
lime white



**D02** grigio Portland  
Portland grey

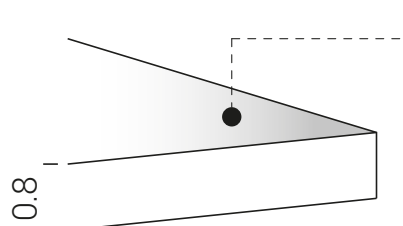

calcestruzzo  
beton  
béton  
Beton  
hormigón



**H01** quarzo  
quartz



**H02** arenaria  
brownstone



**H03** grafite  
graphite



HPL + pietra naturale  
natural stone  
pierre naturelle  
Naturstein  
piedra natural



**P01** grigio cenere  
ash grey



**P02** nero ardesia  
slate black



telaio / structure/ châssis / Gestell / bastidor

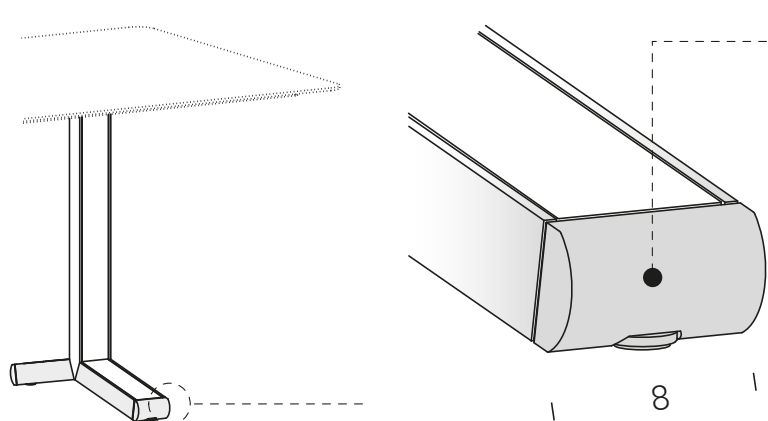

acciaio verniciato  
painted steel  
acier peint  
lackierter Stahl  
acero pintado



**C12** bianco  
white

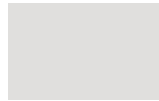

**C21** seta  
silk



**C23** corda  
ecru



**C30** ghisa  
cast-iron



**C14** antracite  
anthracite



**C08** nero  
black



**C18** verde  
green



**C26** corten  
corten



**C29** bronzo  
bronze



uso in esterno riparato  
protected outdoor use

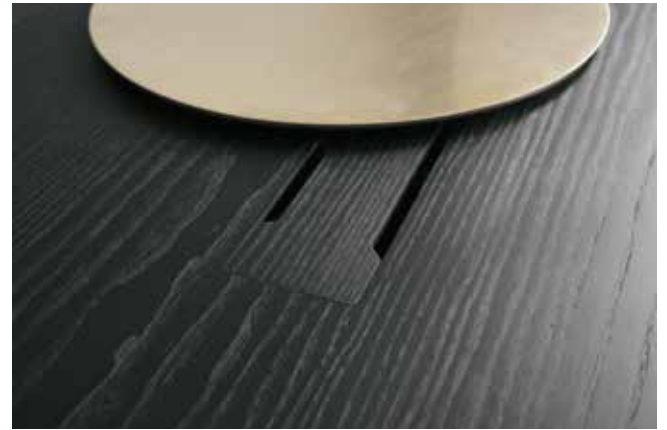





# IPE

IP01

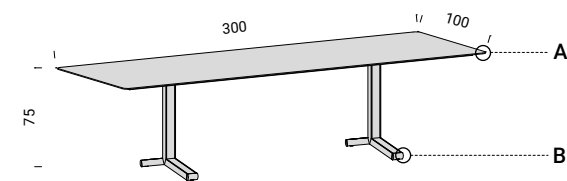

**A**

**Y39**  
frassino nero/black ash

HPL impiallacciato  
wood-veneered HPL  
HPL plaqué bois  
HPL mit Holzfurnier  
HPL contrachapado madera

**B**

**C08**  
nero/black

acciaio verniciato a polveri  
powder coated steel  
acier peint aux poudres  
Pulverlackierter Stahl  
Acero con baño de barniz en polvo

collection info  
pg. 186





# IPE

IP03

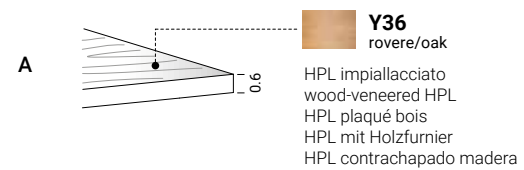
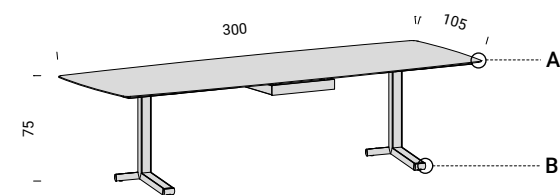

**Y36**  
rovere/oak

HPL impiallacciato  
wood-veneered HPL  
HPL plaqué bois  
HPL mit Holzfurnier  
HPL contrachapado madera

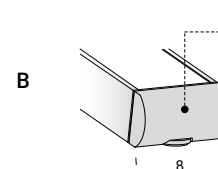

**C29**  
bronzo/bronze

acciaio verniciato a polveri  
powder coated steel  
acier peint aux poudres  
Pulverlackierter Stahl  
Acero con baño de barniz en polvo

collection info  
pg. 186







# IPE

IP02

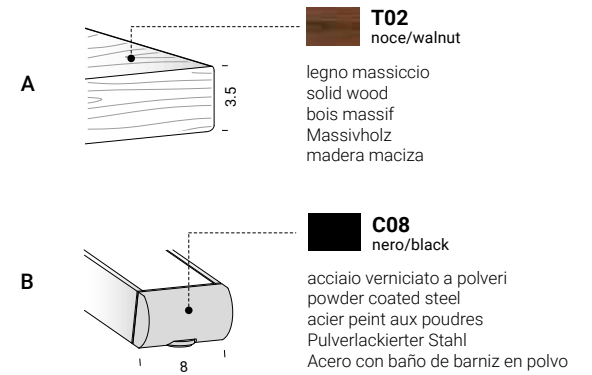
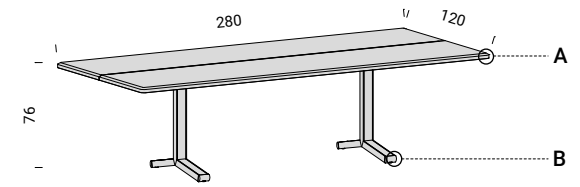

collection info  
pg. 186



# danske T

**L'acciaio ed il legno massiccio si compenetrano generando una purezza volumetrica e valorizzando le essenze di rovere e noce. Come tutti i top in legno massiccio, extendo unisce le tavole grezze con la tecnica del finger joint, (tecnica che consente un' unione stabile, senza elementi estranei di connessione).**

The steel and solid wood permeate to generate volumetric purity and develop the oak and walnut essences. As with all solid wood tops, Extendo joins the rough table using the finger joint technique (which allows stable joinery, without foreign couplings).

L'acier et le bois massif s'interpénètrent en générant une pureté géométrique et en valorisant les essences du chêne rouvre et du noyer. Comme tous les plateaux en bois massif, extendo unit les planches brutes avec la technique du joint par entures multiples ou finger joint, (technique qui permet une union stable, sans éléments de liaison étrangers).

Der Stahl und das Massivholz durchdringen sich gegenseitig, schaffen eine volumetrische Leichtigkeit und bringen die Eiche- und Nussbaumhölzer zur Geltung. Wie bei allen Abschlussborden aus Massivholz werden die unbearbeiteten Holztafeln mit der finger-joint-Methode ohne Verbindungselemente stabil zusammengesetzt.

El acero y la madera maciza se compenetran generando una pureza volumétrica, destacando las maderas de roble y nogal. Como todos los sobres de madera maciza, extendo une las tablas sin tratar con la técnica del "finger joint" (técnica que permite una "unión estable, sin elementos extraños de conexión).



disponibili riduzioni a misura / tailor-made reduction available / disponibles réductions sur mesure / Verkleinerung nach Kundenwunsch / Disponibles reducciones a medida

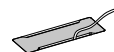

passacavo disponibile per tutti i top / cable gland available for all topspasse-câble disponible pour tous les plateaux / Kabeldurchlass für alle Abschlussborde verfügbar / pasacables disponible para todos los sobres

## materiali / materials



legno massiccio  
solid wood  
bois massif  
Massivholz  
madera maciza



acciaio  
steel  
acier  
Stahl  
acero

Le materie prime che costituiscono il sistema danske T derivano da un processo di riutilizzo e sono a loro volta riciclabili.

The primary materials used in the system danske T are sourced from a reuse process, and are in turn recyclable.

Les matières premières qui composent le système danske T dérivent d'un processus de réutilisation et sont à leur tour recyclables.

Die Rohstoffe für das System danske T entstammen einem Wiederverwertungsprozess und sind ihrerseits wiederum recyclebar.

Las materias primas que constituyen el sistema danske T proceden de un proceso de reutilización y son, a su vez, reciclables.

**tavoli / tables / tables / Tische / mesas**

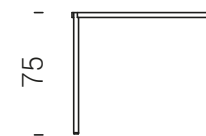
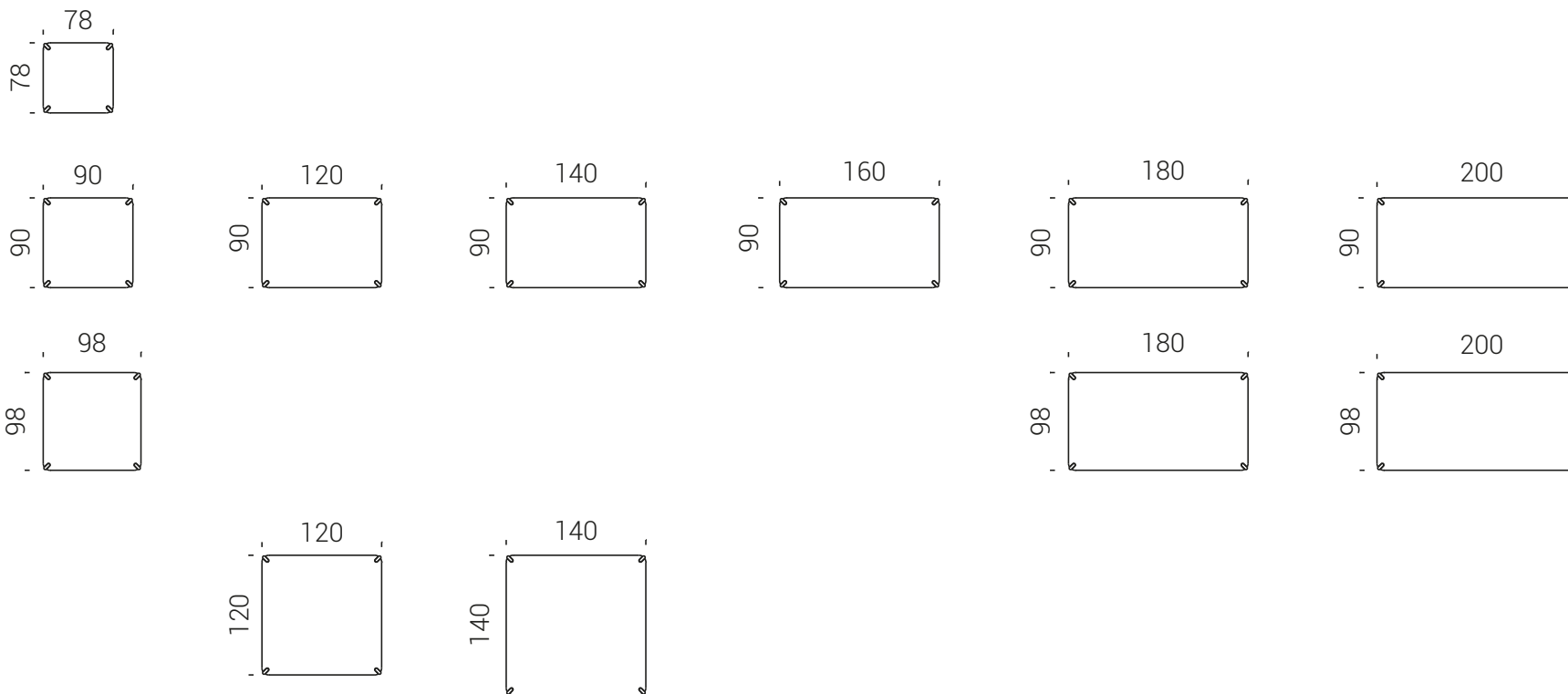

**scrivani / writing desks / secrétaires / Schreibtischen / escritorios**

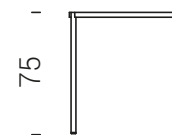

**scrivani a parete / writing desks / secrétaires / Schreibtischen / escritorios**

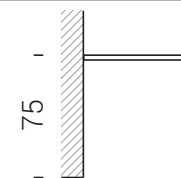
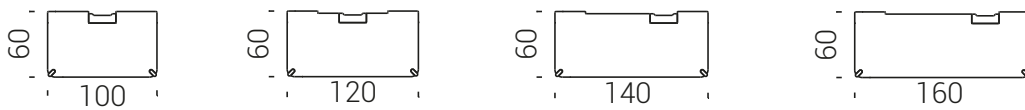

**consolle a parete / writing desks / secrétaires / Schreibtischen / escritorios**

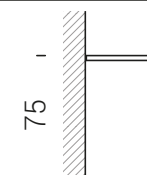
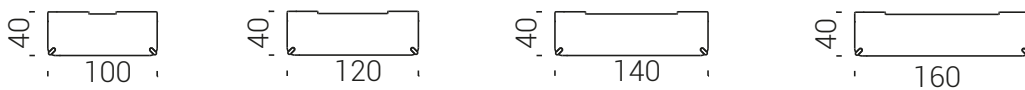

## top tavolo / table top / plateaux de table / Tischplatte / plano de mesa

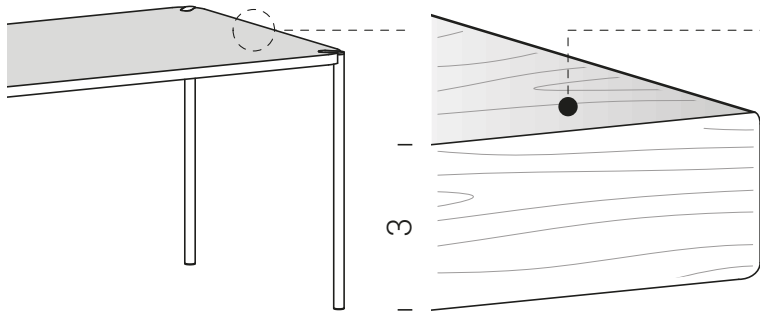

legno massiccio  
solid wood  
bois massif  
Massivholz  
madera maciza



**T01** rovere  
oak



**T02** noce  
walnut



**T03** iroko

## telaio / structure/ châssis / Gestell / bastidor

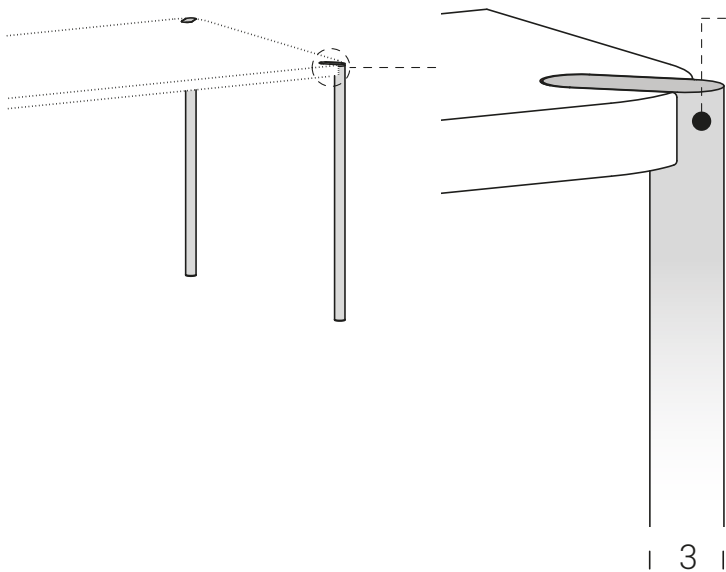

acciaio verniciato  
painted steel  
acier peint  
lackierter Stahl  
acero pintado



**C12** bianco  
white

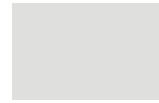

**C21** seta  
silk



**C23** corda  
ecru



**C30** ghisa  
cast-iron



**C14** antracite  
anthracite



**C08** nero  
black



**C18** verde  
green



**C26** corten  
corten



**C29** bronzo  
bronze







## danske T

DT01

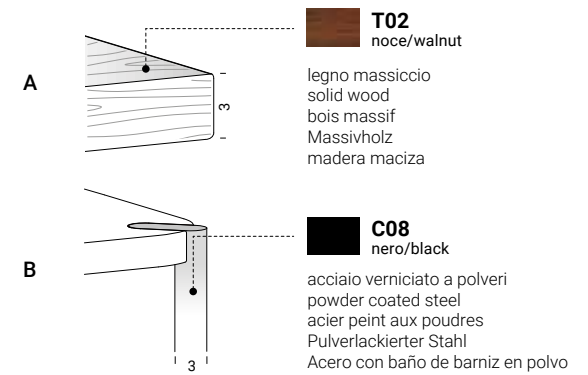
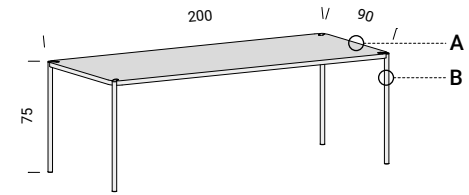

collection info  
pg. 194





## danske T

DT02

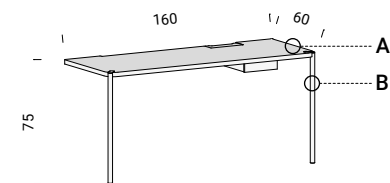

A

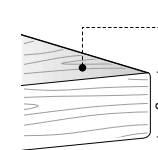

**T01**  
rovere/oak

legno massiccio  
solid wood  
bois massif  
Massivholz  
madera maciza

B

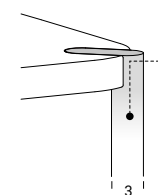

**C14**  
antracite/anthracite

acciaio verniciato a polveri  
powder coated steel  
acier peint aux poudres  
Pulverlackierter Stahl  
Acero con baño de barniz en polvo

collection info  
pg. 194





# hammer

**Progettato senza compromessi per un impiego outdoor, è comunque disponibile nelle finiture noce e rovere massiccio per l'inserimento indoor.**

**Per la versione outdoor il top e le sedute sono in Iroko trattato con olio naturale, il telaio è in acciaio corten, o acciaio verniciato a polveri, gli elementi di connessione sono in acciaio inox e ottone.**

Designed without compromise for outdoor use, it is available in solid walnut and oak finishes for indoor use. For the outdoor version, the top and the chairs are in Iroko treated with natural oil, the frame is in Corten steel or powder painted steel. The joinery elements are in stainless steel or brass.

Conçu sans compromis pour une utilisation en extérieur, il est toutefois disponible dans les finitions noyer et chêne rouvre massif pour l'insertion d'intérieur. Pour la version d'extérieur, le plateau et les assises sont en Iroko traité avec de l'huile naturelle, la structure est en acier Corten, ou en acier verni par poudres, les éléments de connexion sont en acier inox et laiton.

Kompromissloser Entwurf für den Outdoor-Einsatz, steht jedoch auch als Indoor-Lösung mit Endbehandlung Nussbaum und Massiveiche zur Verfügung. Für die Outdoor-Version sind Abschlussbord und Sitze aus mit natürlichem Öl behandeltem Iroko, der Rahmen ist aus Corten-Stahl oder pulverlackiertem Stahl und die Verbindungsstücke sind aus Edelstahl und Messing.

Diseñada para usarla sin problemas en el exterior, también está disponible en los acabados nogal y roble macizo para su uso en el interior. Para la versión de exterior el sobre y los asientos son de iroko tratado con aceite natural, el bastidor es de acero corten, o acero tratado con barniz en polvo, los elementos de unión son de acero inoxidable y latón.



disponibili riduzioni a misura / custom reductions available / réductions sur mesure disponibles / Verkürzungen auf Maß erhältlich / disponibles reducciones a medida



iroko outdoor trattato ad olio 100% vegetale / iroko outdoor treated with 100% vegetable oil / iroko outdoor traité à l'huile 100% végétale / iroko Outdoor behandelt mit 100% pflanzlichem Öl / iroko para exteriores, tratado con aceite 100% vegetal

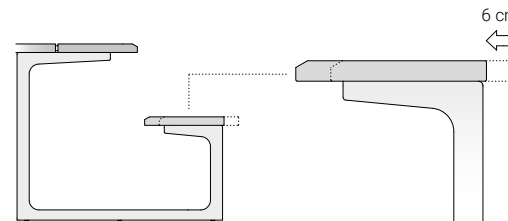

## materiali / materials



legno massiccio  
solid wood bois  
massif Massivholz  
madera maciza



acciaio  
steel  
acier  
Stahl  
acero



corten

Le materie prime che costituiscono il sistema hammer derivano da un processo di riutilizzo e sono a loro volta riciclabili.

The primary materials used in the system hammer are sourced from a reuse process, and are in turn recyclable.

Les matières premières qui composent le système hammer dérivent d'un processus de réutilisation et sont à leur tour recyclables.

Die Rohstoffe für das System hammer entstammen einem Wiederverwertungsprozess und sind ihrerseits wiederum recyclebar.

Las materias primas que constituyen el sistema hammer proceden de un proceso de reutilización y son, a su vez, reciclables.

**tavoli con panca / tables with bench / tables avec banc  
Tische mit Bänken / mesitas con un banquillo**

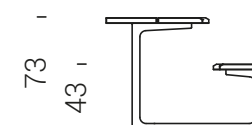
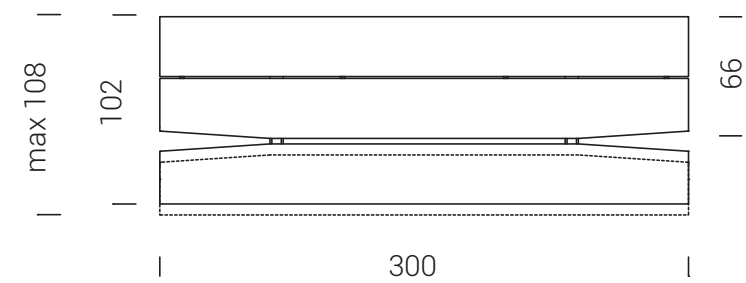
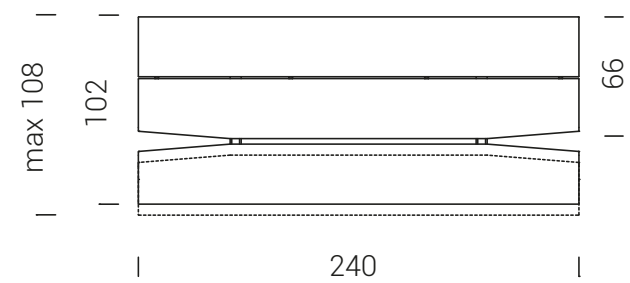
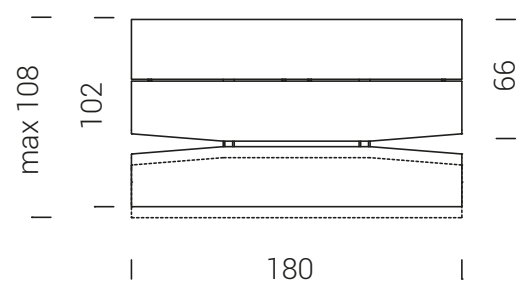
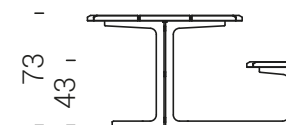
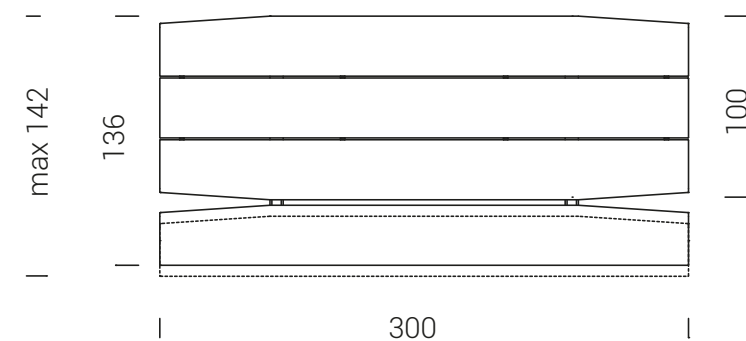
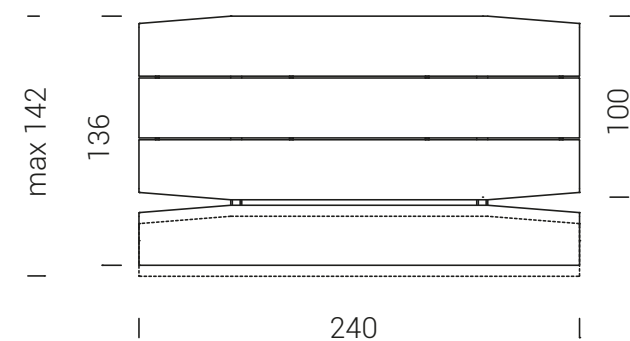
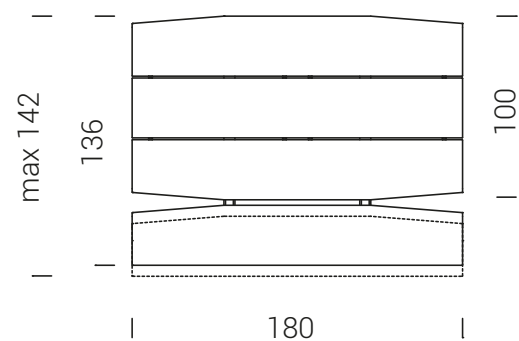
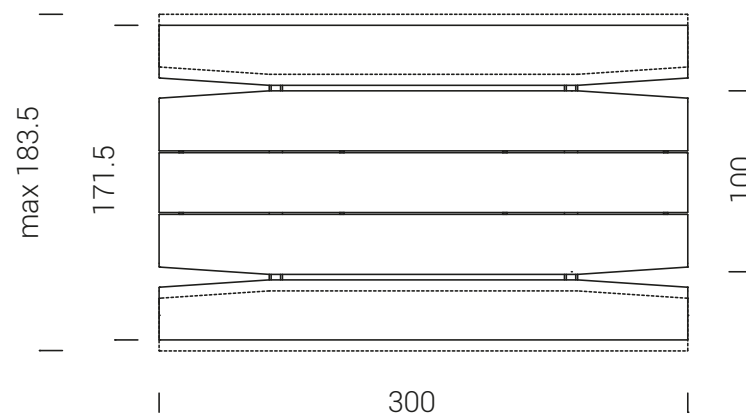
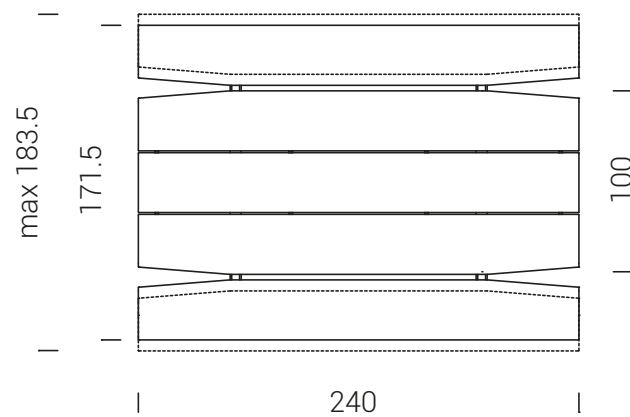
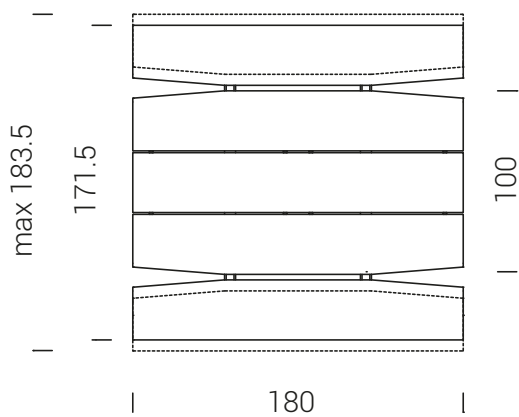
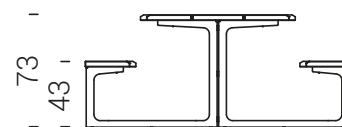

**tavoli / tables / tables / Tischen / mesas**

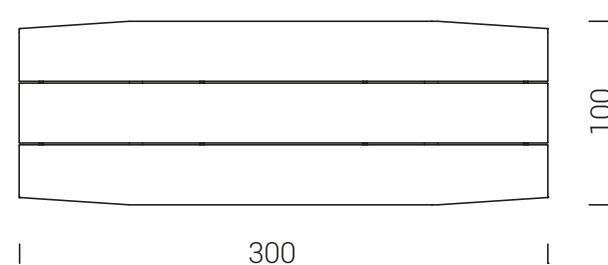
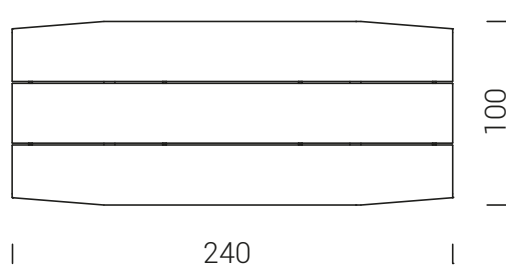
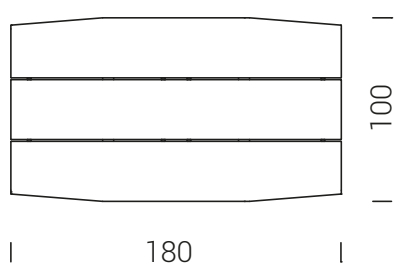
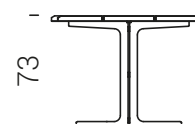

top tavolo / table top / plateaux de table / Tischplatte / plano de mesa

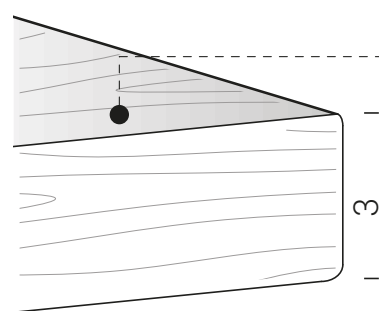
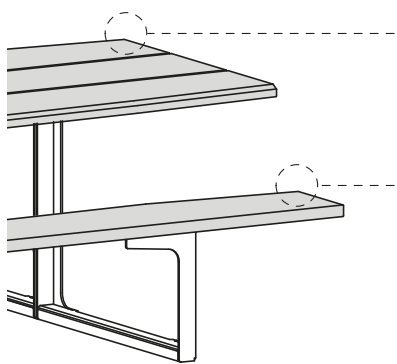

legno massiccio  
solid wood  
bois massif  
Massivholz  
madera maciza



**T01** rovere  
oak



**T02** noce  
walnut



**T03** iroko



**T04** iroko outdoor



telaio / structure/ châssis / Gestell / bastidor

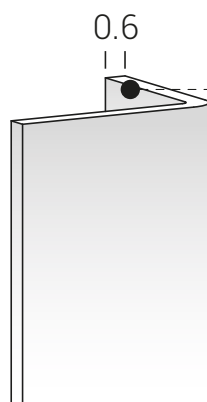
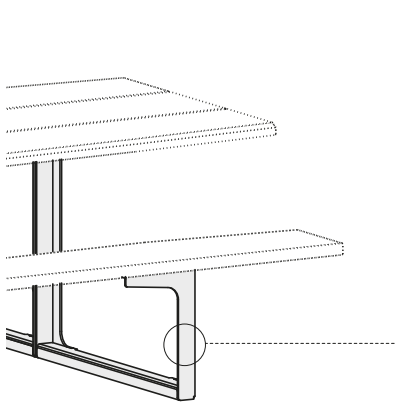

acciaio verniciato  
painted steel  
acier peint  
lackierter Stahl  
acero pintado



**C12** bianco  
white



**C21** seta  
silk



**C23** corda  
ecru



**C30** ghisa  
cast-iron



**C14** antracite  
anthracite



**C08** nero  
black



**C18** verde  
green



**C26** corten  
corten



**C29** bronzo  
bronze



**C27** corten outdoor  
corten outdoor



uso in esterno  
full outdoor use









# hammer

HA04

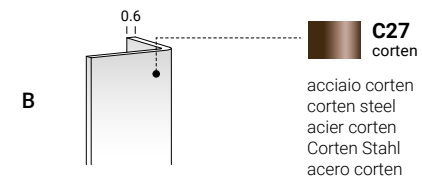
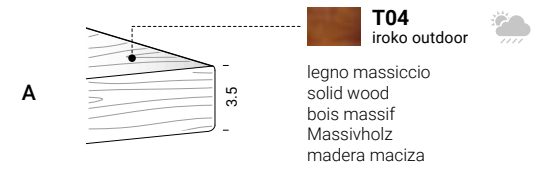
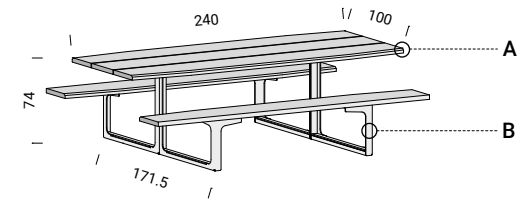

collection info  
pg. 200







## hammer

HA05

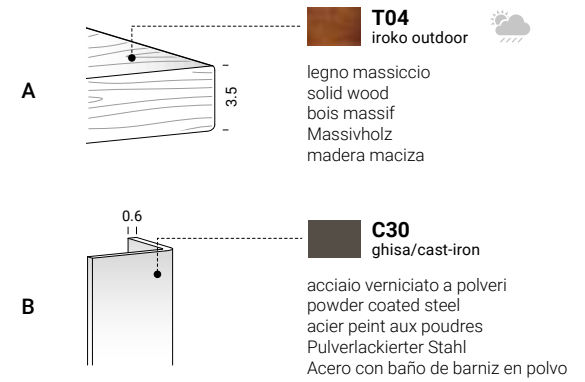
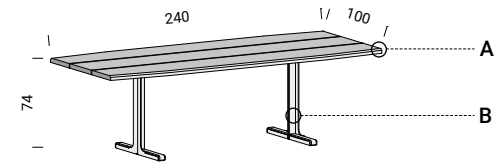

collection info  
pg. 200







## hammer

HA06

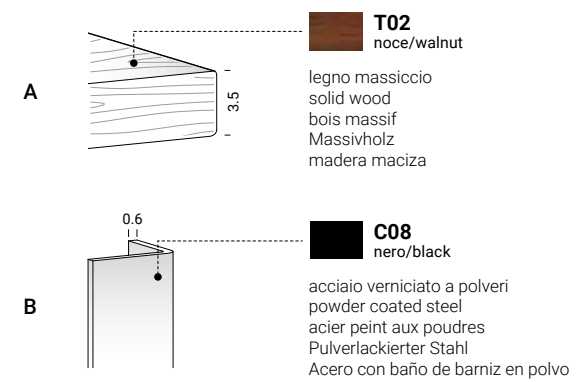
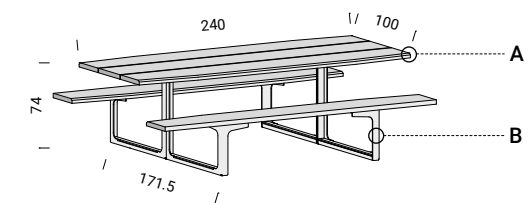

collection info  
pg. 200





## hammer

HA03

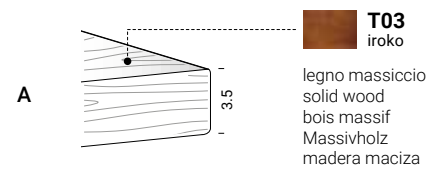
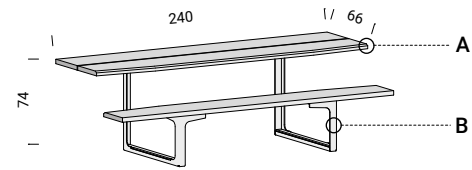

collection info  
pg. 200



## hammer

HA02

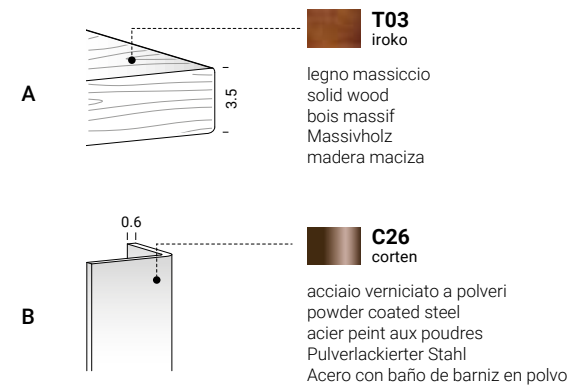
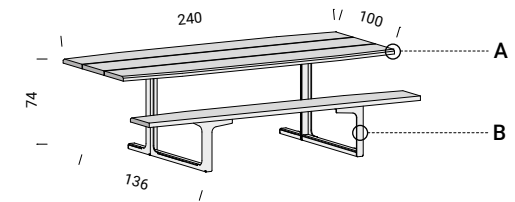

collection info  
pg. 200

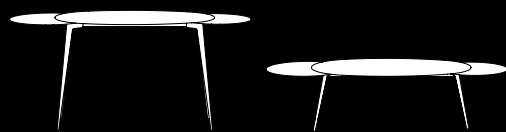

# mr.hyde

**mr.hyde è una collezione di tavoli che nascondono nella parte sottostante uno o più dischi con diametro 48-54 cm. I dischi possono essere estratti ruotandoli, aumentando la superficie disponibile del tavolino. I top mr.hyde ed i dischi estraibili sono in hpl spessore 6 mm che nello sviluppo del perimetro viene ridotto tramite fresatura ad uno spessore di soli 3 mm.**

mr.hyde is a collection of tables with one or more hidden discs of diameters between 48 and 54 cm. The discs can be extracted by turning them, thus increasing the available space on the table. The mr.hyde tops and extractable discs are in 6 mm HPL, milled around the edge to a thickness of just 3 mm.

mr.hyde est une collection de tables de café qui cachent dans la partie sous-jacente un ou plusieurs disques avec un diamètre de 48-54 cm. Les disques peuvent être extraits en les faisant tourner, en augmentant ainsi la superficie disponible de la table basse. Les plateaux mr.hyde et les disques extractibles sont réalisés en HPL de 6 mm d'épaisseur, qui est réduite par fraisage le long du périmètre à une épaisseur de seulement 3 mm.

mr.hyde ist eine Kollektion von Tables, die auf der Unterseite eine oder mehrere runde Platten mit einem Durchmesser von 48-54 cm verbergen. Die runden Platten können herausgedreht werden und vergrößern so die Ablagefläche des Tisches. Die HPL-Tischplatte und die runden Platten sind aus 6 mm starkem HPL gefertigt, der Rand ist dagegen auf eine Stärke von 3 mm.

mr.hyde es una colección de tables que esconden en la parte inferior uno o varios discos, con un diámetro de 48-54 cm. Los discos pueden extraerse girándolos, aumentando la superficie disponible de la mesita. Los sobres de mr.hyde y los discos extraíbles son de hpl, de 6 mm de espesor, que en el desarrollo del perímetro se reduce a través de fresado a un espesor solo de 3 mm.



## materiali / materials



HPL+legno  
HPL+wood  
HPL+bois  
HPL+Holz  
HPL+madera



HPL



acciaio  
steel  
acier  
Stahl  
acero

Le materie prime che costituiscono il sistema mr.hyde derivano da un processo di riutilizzo e sono a loro volta riciclabili.

The primary materials used in the system mr.hyde are sourced from a reuse process, and are in turn recyclable.

Les matières premières qui composent le système mr.hyde dérivent d'un processus de réutilisation et sont à leur tour recyclables.

Die Rohstoffe für das System mr.hyde entstammen einem Wiederverwertungsprozess und sind ihrerseits wiederum recyclebar.

Las materias primas que constituyen el sistema mr.hyde proceden de un proceso de reutilización y son, a su vez, reciclables.



**tavoli / tables / tables / Tische / mesas**

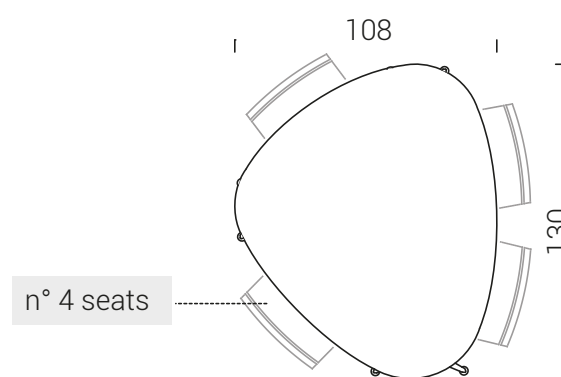
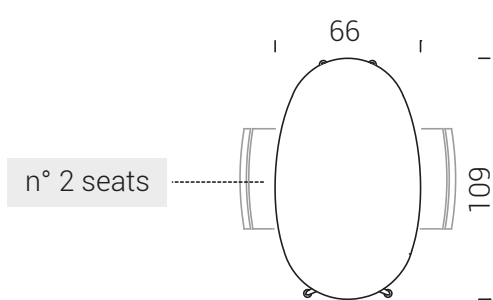

**tavoli ampliabili / extension tables / tables à rallonges / Erweiterbare Tische / mesas ampliables**

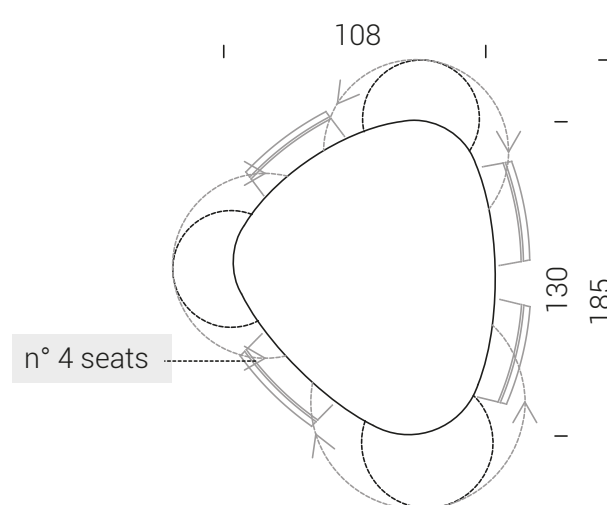
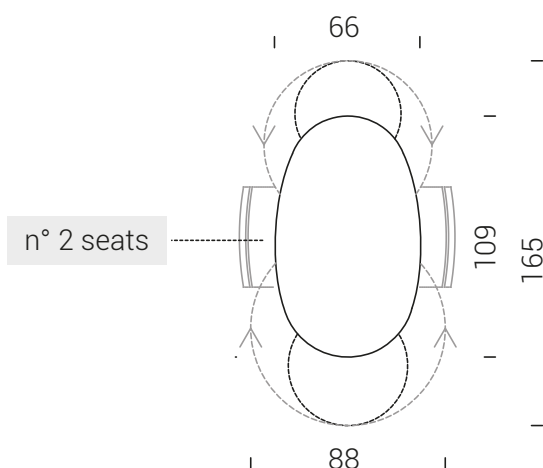

**tavoli bassi / coffee tables / tables basses / Couchtische / mesas bajas**

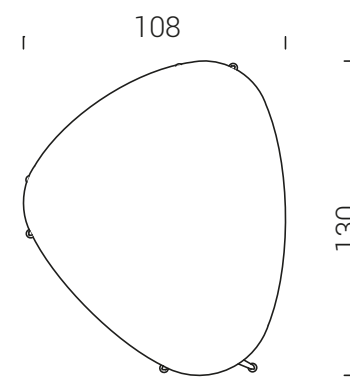
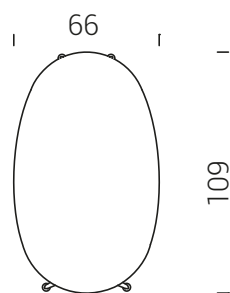
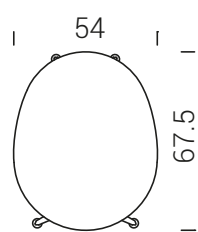

**tavoli bassi ampliabili / extension coffee tables / tables basses à rallonges / Erweiterbare Couchtische / mesas bajas ampliables**

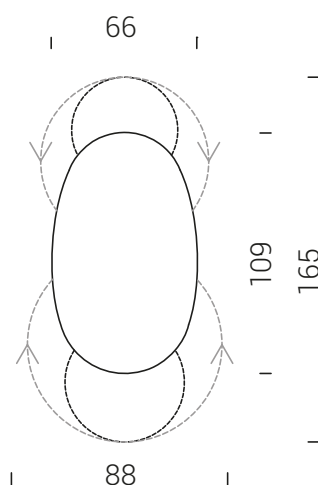
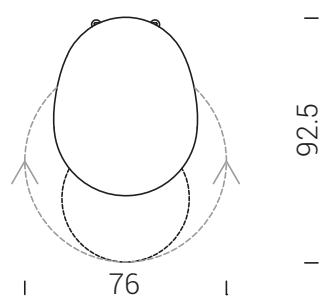

top tavolo / table top / plateaux de table / Tischplatte / plano de mesa

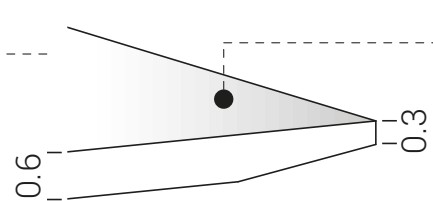
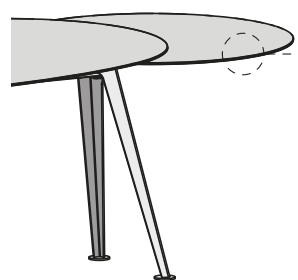

HPL



**L03** bianco  
white



Fenix®



**L08** grigio Londra  
London grey



**L06** nero  
black



HPL + legno  
wood  
bois  
Holz  
madera



**Y36** rovere  
oak



**Y34** noce  
walnut



**Y37** rovere affumicato  
smoked oak

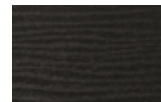

**Y39** frassino nero  
black arsh

HPL + metallo  
metal  
métal  
Metall  
metal



**C31** ottone  
brass



**C32** ottone scuro  
dark brass



**C35** inox  
inox



**C36** inox scuro  
dark inox



HPL + ecotouch



**N01** sabbia  
sand



**N02** basalto  
basalt

HPL + cemento  
concrete  
ciment  
zement  
cemento



**D01** bianco calce  
lime white



**D02** grigio Portland  
Portland grey

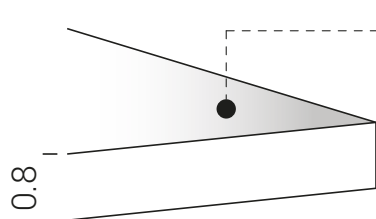

HPL + pietra naturale  
natural stone  
pierre naturelle  
Naturstein  
piedra natural



**P01** grigio cenere  
ash grey



**P02** nero ardesia  
slate black



telaio / structure/ châssis / Gestell / bastidor

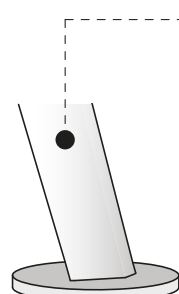
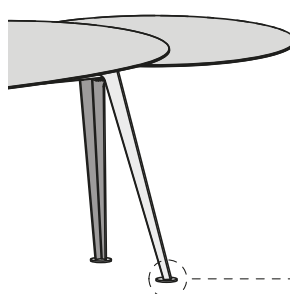

acciaio verniciato  
painted steel  
acier peint  
lackierter Stahl  
acero pintado



**C12** bianco  
white



**C21** seta  
silk



**C23** corda  
ecru



**C30** ghisa  
cast-iron



**C14** antracite  
anthracite



**C08** nero  
black



**C18** verde  
green



**C26** corten  
corten



**C29** bronzo  
bronze



uso in esterno riparato  
protected outdoor use





**mr.hyde**  
MH28

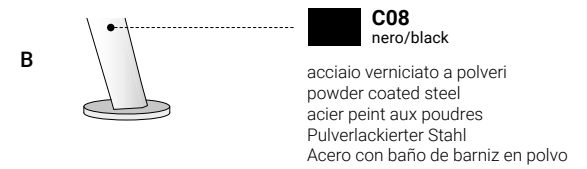
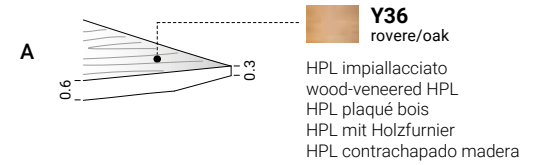
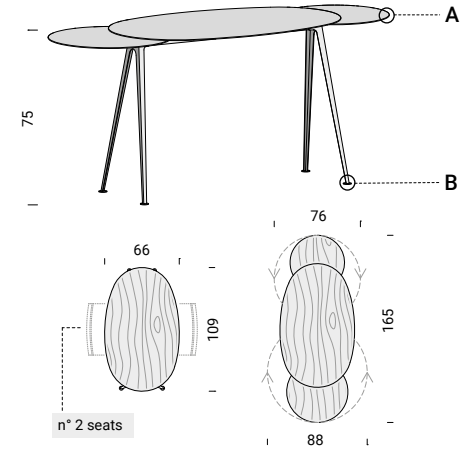

collection info  
pg. 210







**mr.hyde**  
MH29

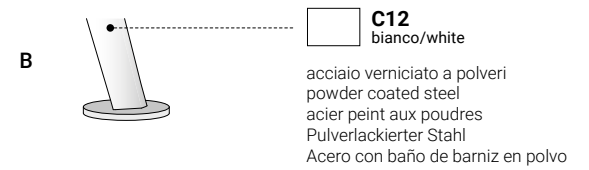
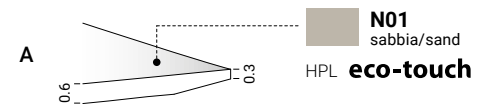
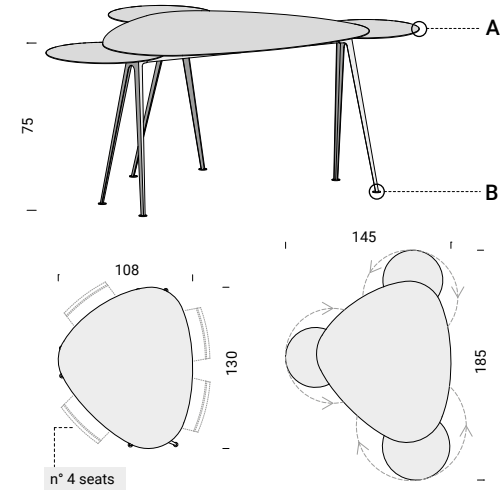

collection info  
pg. 210



**mr.hyde**  
MH01

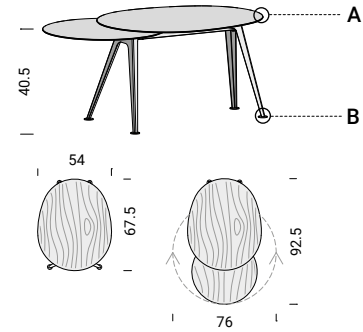

**A**

**Y36**  
rovere/oak

HPL impiallacciato  
wood-veneered HPL  
HPL plaqué bois  
HPL mit Holzfurnier  
HPL contrachapado madera

**B**

**C14**  
antracite/anthracite

acciaio verniciato a polveri  
powder coated steel  
acier peint aux poudres  
Pulverlackierter Stahl  
Acero con baño de barniz en polvo

collection info  
pg. 210



**mr.hyde**  
MH07

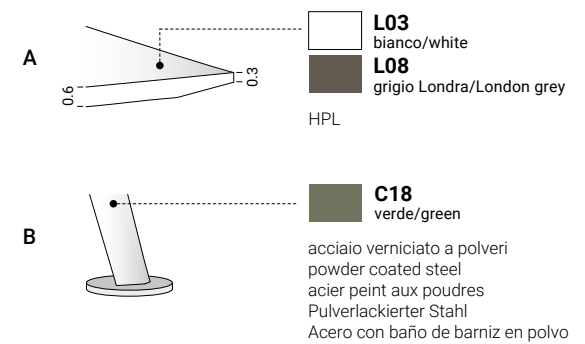
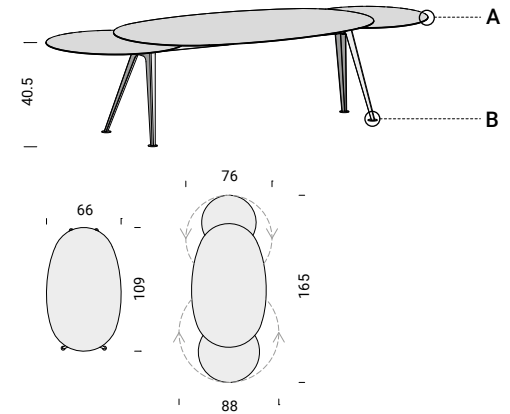

collection info  
pg. 210







**mr.hyde**  
MH02

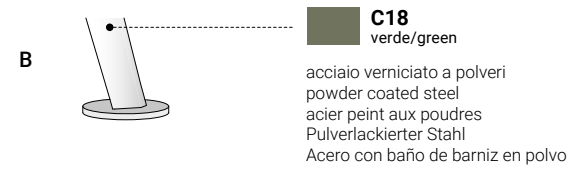
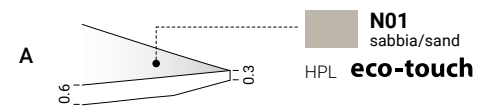
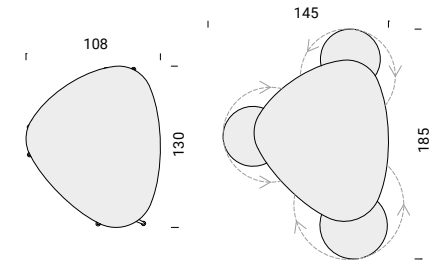
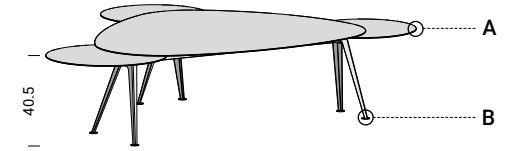

collection info  
pg. 210



# déco

**Una collezione di tavolini che si ispira ad uno stile che ha influenzato l'architettura ed il design negli anni 30. Le nuove tecnologie per la lavorazione dei metalli e le alte performance dei materiali impiegati, hanno consentito di reinterpretare uno stile dalle forme classiche in geometrie contemporanee.**

This is a collection of coffee tables inspired by a style that influenced both the fields of architecture and design during the 1930s. The new metalworking technologies and the high-performing materials used, have made it possible to re-interpret a style with classical forms in contemporary profiles.

Une collection de tables basses qui s'inspire d'un style qui a influencé l'architecture et le design dans les années 30. Les nouvelles technologies pour l'usinage des métaux et les performances élevées des matériaux employés ont permis de réinterpréter un style aux formes classiques en géométries contemporaines.

Eine Kollektion von Tischen, die sich am Art Déco inspiriert, einer Stilrichtung, die die Architektur und das Design der 1930er Jahre beeinflusst hat. Innovative Technologien bei der Metallbearbeitung und leistungsfähige Materialien erlauben die Neuinterpretation eines von klassischen Formen geprägten Stils, die mit zeitgenössischen Konturen überzeugt.

Una colección de mesitas inspirada en el estilo que predominó en la arquitectura y el diseño de los años 30. Las nuevas tecnologías para el procesamiento de metales y las altas prestaciones de los materiales utilizados, permitieron reinterpretar un estilo caracterizado por formas clásicas, creando geometrías contemporáneas.



## materiali / materials



HPL+legno  
HPL+wood  
HPL+bois  
HPL+Holz  
HPL+madera



HPL



acciaio  
steel  
acier  
Stahl  
acero

Le materie prime che costituiscono il sistema déco derivano da un processo di riutilizzo e sono a loro volta riciclabili.

The primary materials used in the system déco are sourced from a reuse process, and are in turn recyclable.

Les matières premières qui composent le système déco dérivent d'un processus de réutilisation et sont à leur tour recyclables.

Die Rohstoffe für das System déco entstammen einem Wiederverwertungsprozess und sind Ihrerseits wiederum recyclebar.

Las materias primas que constituyen el sistema déco proceden de un proceso de reutilización y son, a su vez, reciclables.

**tavoli bassi / coffee tables / tables basses / Couchtische / mesas bajas**

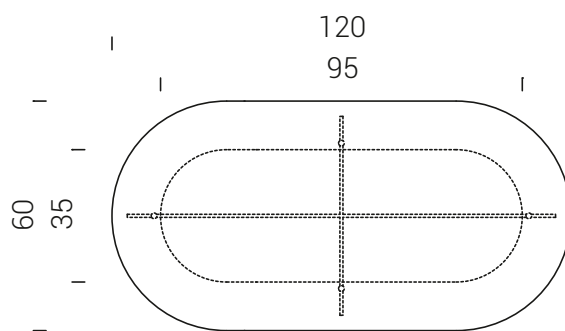
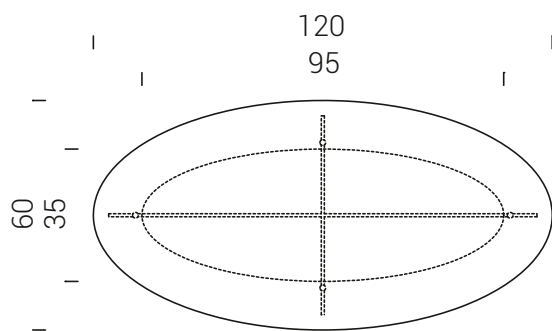
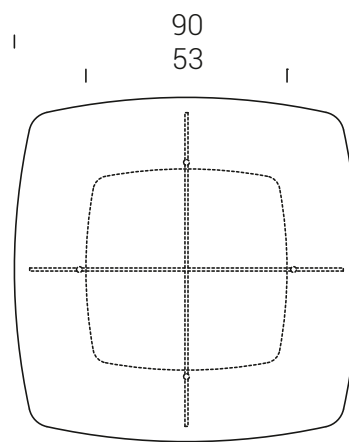
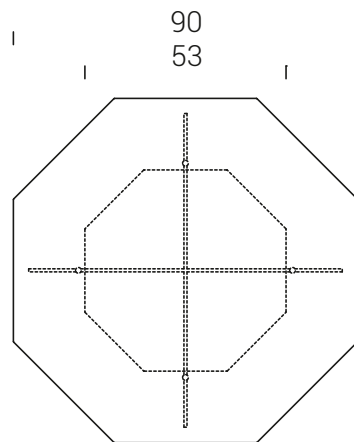
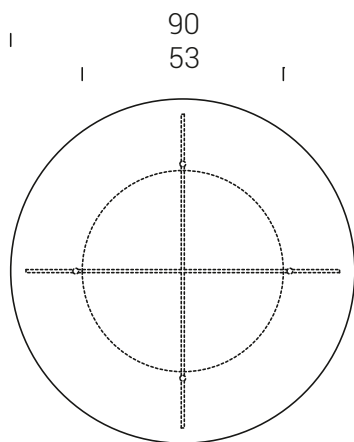

**tavoli bassi / coffee tables / tables basses / Couchtische / mesas bajas**

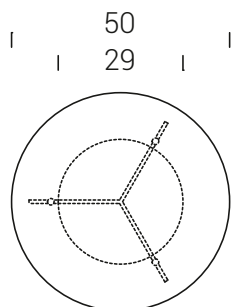



top tavolo / table top / plateaux de table / Tischplatte / plano de mesa

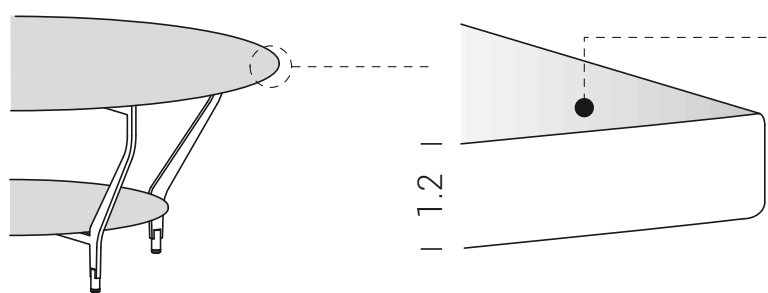

marmo  
marble  
marbre  
Marmor  
mármol



**Z01** bianco Carrara  
white Carrara  
**Z02** nero Marquiña  
black Marquiña

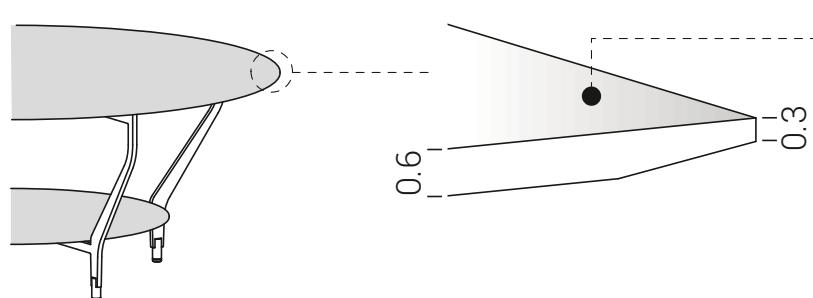

HPL



**L03** bianco  
white



Fenix®



**L08** grigio Londra  
London grey



**L06** nero  
black



HPL + legno  
wood  
bois  
Holz  
madera



**Y36** rovere  
oak



**Y34** noce  
walnut



**Y37** rovere affumicato  
smoked oak



**Y39** frassino nero  
black arsh

HPL + metallo  
metal  
métal  
Metall  
metal



**C31** ottone  
brass



**C32** ottone scuro  
dark brass



**C35** inox  
inox



**C36** inox scuro  
dark inox



HPL + ecotouch



**N01** sabbia  
sand



**N02** basalto  
basalt

HPL + cemento  
concrete  
ciment  
zement  
cemento



**D01** bianco calce  
lime white



**D02** grigio Portland  
Portland grey

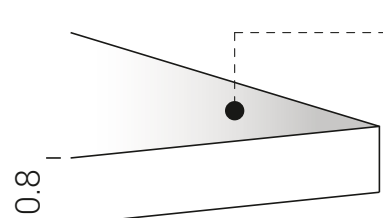

calcestruzzo  
beton  
béton  
Beton  
hormigón



**H01** quarzo  
quartz



**H02** arenaria  
brownstone



**H03** grafite  
graphite



HPL + pietra naturale  
natural stone  
pierre naturelle  
Naturstein  
piedra natural



**P01** grigio cenere  
ash grey



**P02** nero ardesia  
slate black



telaio / structure/ châssis / Gestell / bastidor

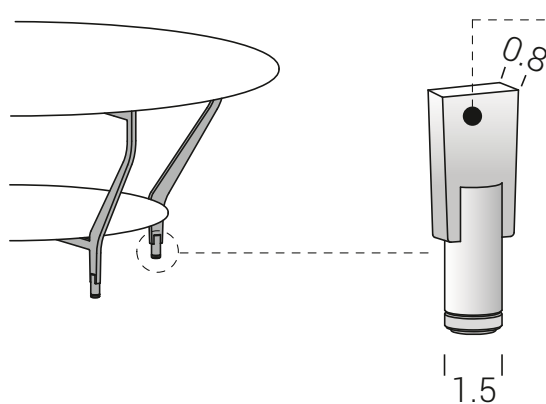

acciaio verniciato  
painted steel  
acier peint  
lackierter Stahl  
acero pintado

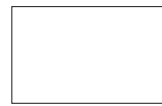

**C12** bianco  
white

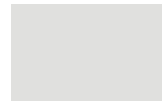

**C21** seta  
silk



**C23** corda  
ecru



**C30** ghisa  
cast-iron



**C14** antracite  
anthracite



**C08** nero  
black



**C18** verde  
green



**C26** corten  
corten



**C29** bronzo  
bronze

uso in esterno riparato  
sheltered outdoor use





**déco**  
DE03

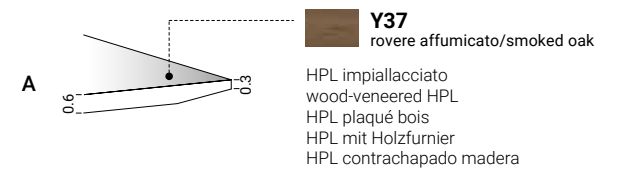
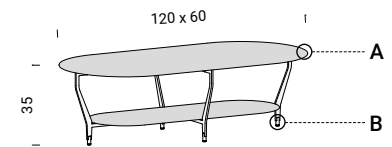

collection info  
pg. 220



**déco**  
DE06

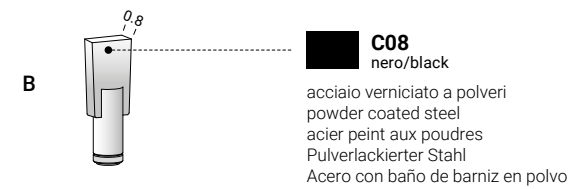
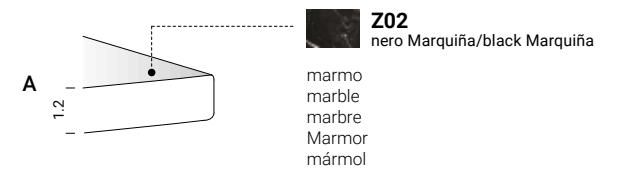
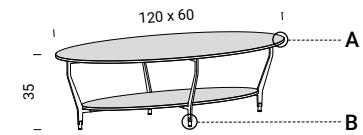

collection info  
pg. 220



## déco

DE01

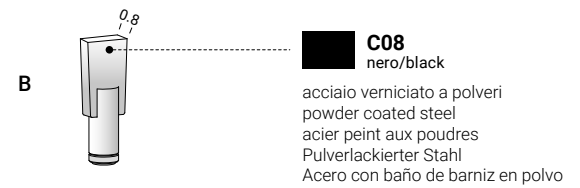
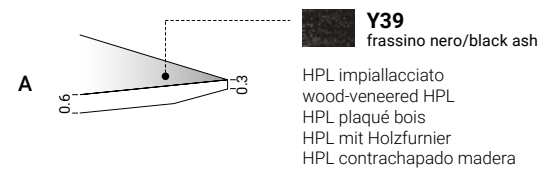
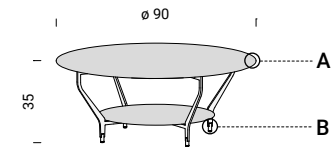

collection info  
pg. 220





**déco**  
DE05

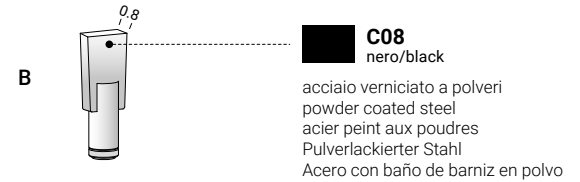
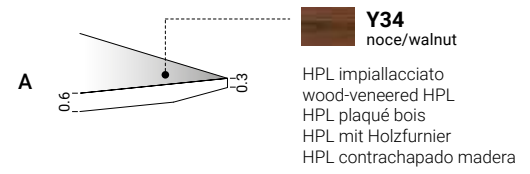
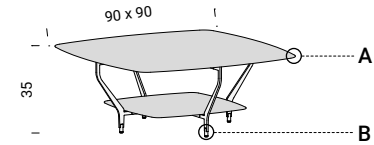

collection info  
pg. 220



**déco**  
DE02

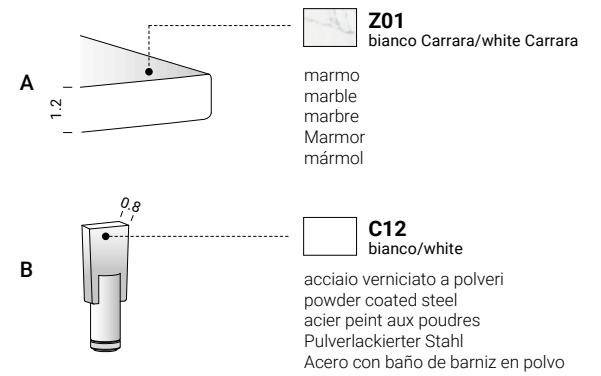
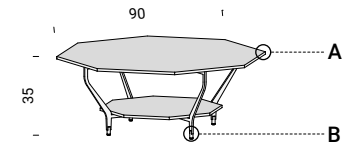

collection info  
pg. 220



## déco

DE04

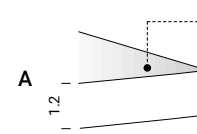
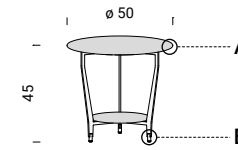

**Z02**  
nero Marquiña/black Marquiña

marmo  
marble  
marbre  
Marmor  
mármol

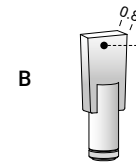

**C14**  
antracite/anthracite

acciaio verniciato a polveri  
powder coated steel  
acier peint aux poudres  
Pulverlackierter Stahl  
Acero con baño de barniz en polvo

collection info  
pg. 220

# seating



**viking K**  
pg. 232



**danske C1**  
pg. 246



**viking W**  
pg. 236



**danske C2**  
pg. 248



**viking L**  
pg. 238



**danske C3**  
pg. 252

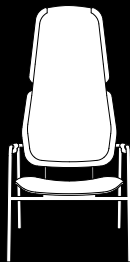

**viking GL**  
pg. 240







# viking

**La lama in acciaio che ricorda il profilo di chiglia delle navi vichinghe è la spina dorsale di tutte le sedute che fanno parte della collezione. Su di essa si innestano il fondello lo schienale e gli appoggi a terra. Il telaio è in acciaio, mentre i componenti di seduta e schienale sono disponibili in multistrato o cuoio.**

The steel blade recalling the contour of the keel of Viking ships is the backbone of all the chairs belonging to this collection. The chair seat, the backrest and the chair legs are inserted onto this. The chair frame is made of steel, while the seat and backrest are available in either plywood or leather.

La lame en acier qui rappelle le profil de la quille des navires vikings est l'épine dorsale de toutes les assises qui font partie de la collection. C'est sur elle que s'enclenchent le fond, le dossier et les appuis au sol. Le châssis est en acier alors que les composants de l'assise et du dossier sont disponibles en multicouche ou en cuir.

Ein Stahlprofil, das an den Rumpf der Wikingerschiffe erinnert, stellt das Rückgrat aller Stühle dieser Kollektion dar, an dem die Sitzfläche, die Rückenlehne und die Bodenstützen befestigt sind. Der Rahmen ist aus Stahl gefertigt, während die Sitzflächen und die Lehnen in Sperrholz oder Leder erhältlich sind.

La cuchilla de acero que recuerda el perfil de la quilla de los barcos vikingos, es la espina dorsal de todos los asientos que forman parte de la colección. Sobre ella, se ensamblan el fondo, el respaldo y los apoyos en el suelo. El bastidor es de acero, mientras que los componentes del asiento y el respaldo, están disponibles en madera estratificada o cuero.



## materiali / materials

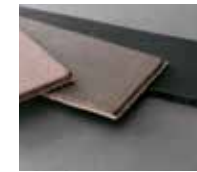

cuoio  
cow-hide  
cuir  
Kernleder  
cuero



multistrato  
plywood  
contre-plaqué  
Sperrholz  
contrachapado



acciaio  
steel  
acier  
Stahl  
acero

Le materie prime che costituiscono il sistema viking derivano da un processo di riutilizzo e sono a loro volta riciclabili.

The primary materials used in the system viking are sourced from a reuse process, and are in turn recyclable.

Les matières premières qui composent le système viking dérivent d'un processus de réutilisation et sont à leur tour recyclables.

Die Rohstoffe für das System viking entstammen einem Wiederverwertungsprozess und sind Ihrerseits wiederum recyclebar.

Las materias primas que constituyen el sistema viking proceden de un proceso de reutilización y son, a su vez, reciclables.

K

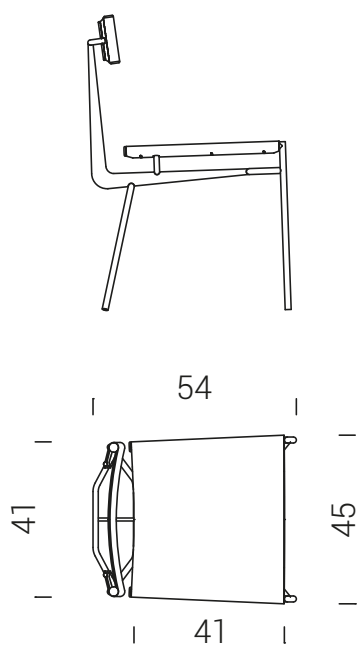
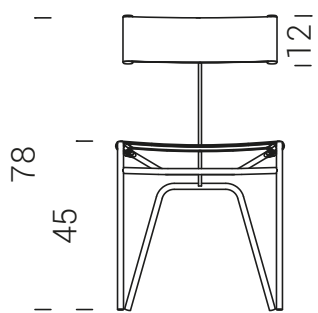

W

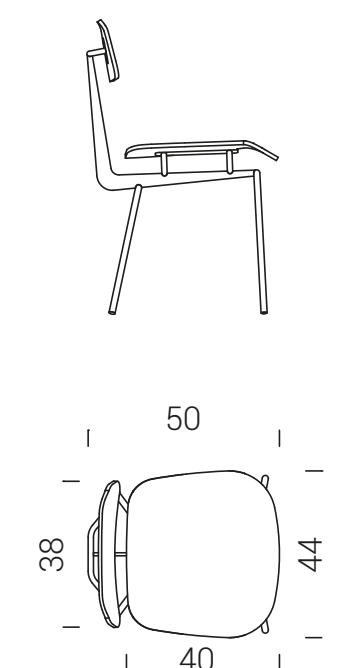
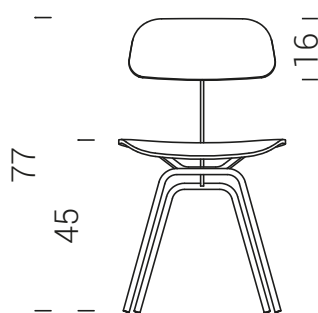

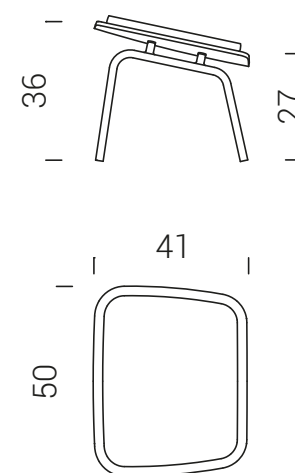
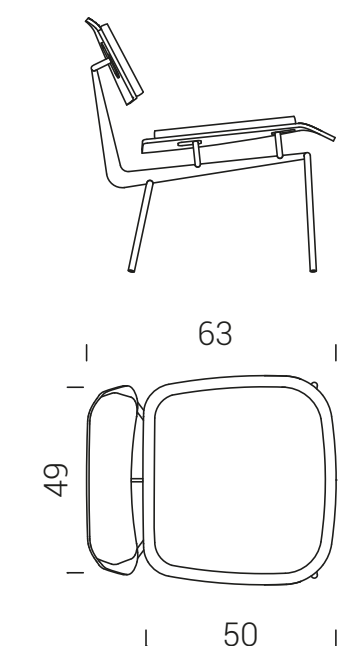
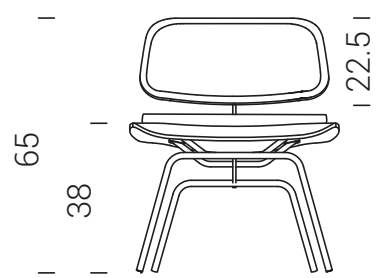

L



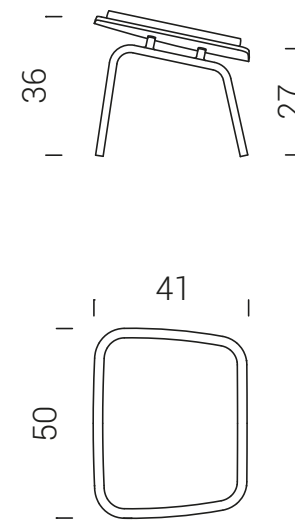
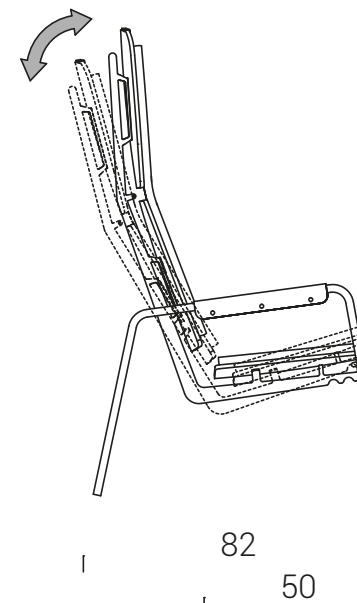
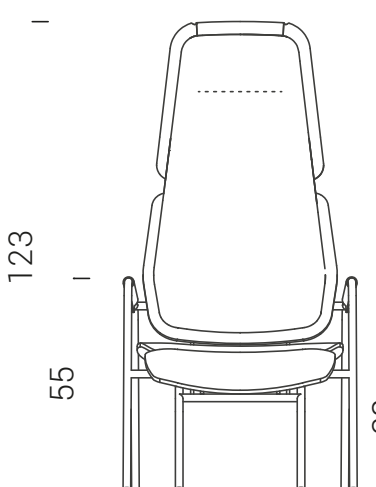

GL

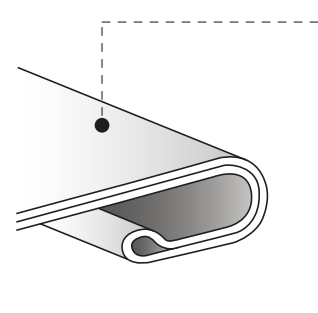

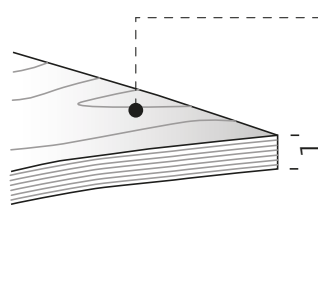
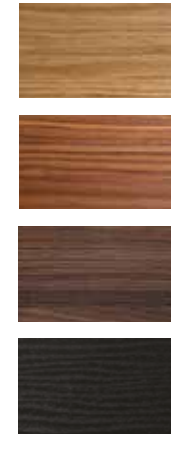
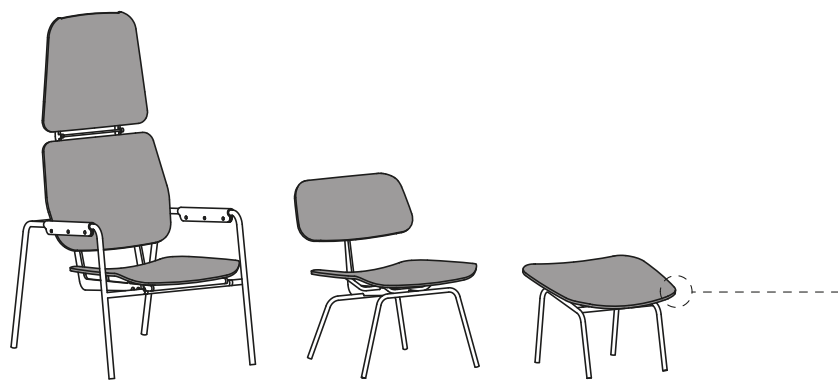
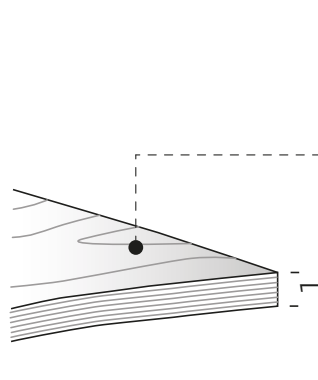
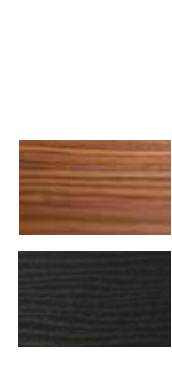

fondello e schienale / seat and back / assise et dossier / Sitzfläche und Rückenlehne / asiento y respaldo

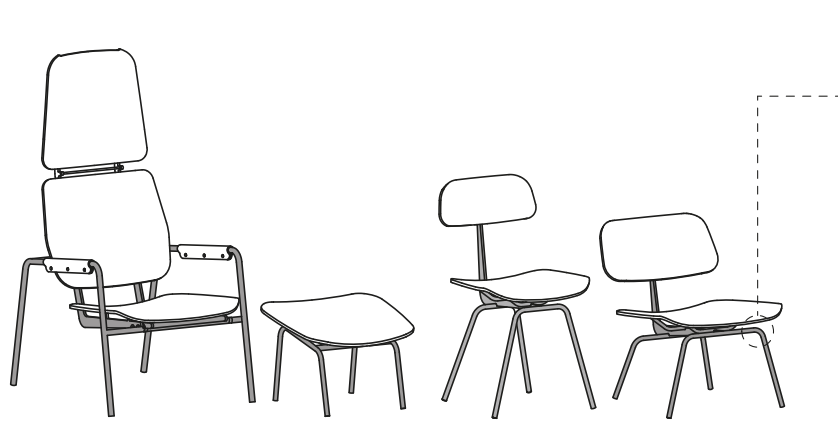
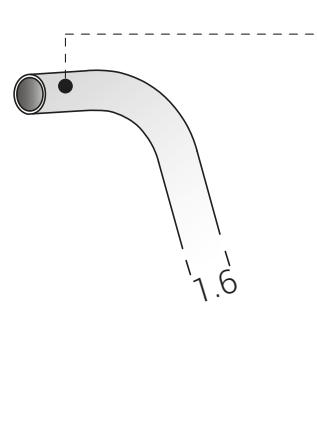
|  |  |  |   |   |
|--|--|--|---|---|
|    |    | <p>cuoio<br/>cow-hide<br/>cuir<br/>Kernleder<br/>cuero</p>                       |    | <p><b>F01</b> tabacco<br/>tobacco</p> <p><b>F03</b> corteccia<br/>bark</p> <p><b>F02</b> nero<br/>black</p>   |
|    |    | <p>multistrato<br/>plywood<br/>contre-plaqué<br/>Sperrholz<br/>contrachapado</p> |   | <p><b>Y36</b> rovere<br/>oak</p> <p><b>Y34</b> noce<br/>walnut</p> <p><b>Y37</b> rovere affumicato<br/>smoked oak</p> <p><b>Y38</b> rovere nero<br/>black oak</p> |
|  |  | <p>multistrato<br/>plywood<br/>contre-plaqué<br/>Sperrholz<br/>contrachapado</p> |  | <p><b>Y34</b> noce<br/>walnut</p> <p><b>Y38</b> rovere nero<br/>black oak</p>   |

telaio / structure/ châssis / Gestell / bastidor

|  |  |  |   |   |
|--|--|--|---|---|
|  |  | <p>acciaio verniciato<br/>painted steel<br/>acier peint<br/>lackierter Stahl<br/>acero pintado</p> |  | <p><b>C12</b> bianco<br/>white</p> <p><b>C21</b> seta<br/>silk</p> <p><b>C23</b> corda<br/>ecru</p> <p><b>C30</b> ghisa<br/>cast-iron</p> <p><b>C14</b> antracite<br/>anthracite</p> <p><b>C08</b> nero<br/>black</p> <p><b>C18</b> verde<br/>green</p> <p><b>C26</b> corten<br/>corten</p> <p><b>C29</b> bronzo<br/>bronze</p> |
|--|--|--|---|---|

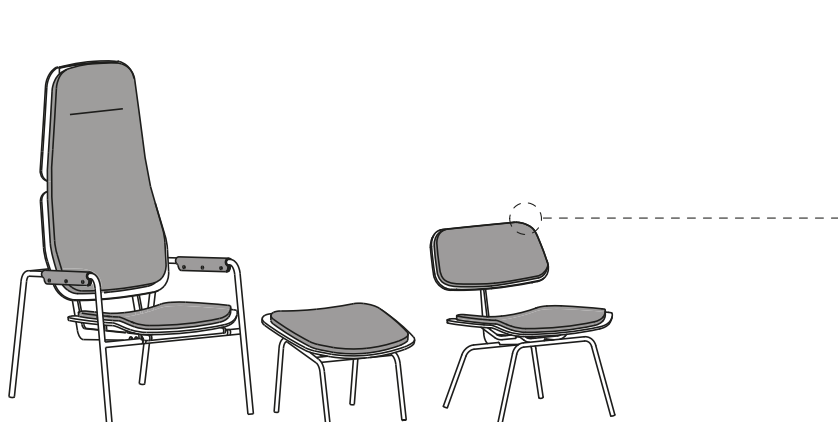
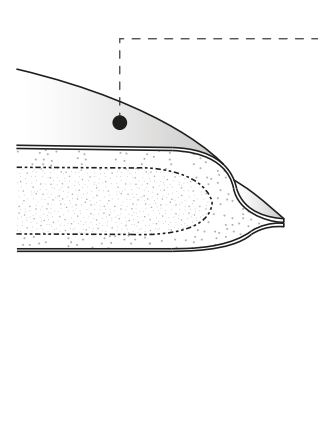
cuscinio / cushion / coussin / Kissen / cojín

|  |  |  |   |   |
|--|--|--|---|---|
|  |  | <p>cuoio<br/>cow-hide<br/>cuir<br/>Kernleder<br/>cuero</p> |  | <p><b>F01</b> tabacco<br/>tobacco</p> <p><b>F03</b> corteccia<br/>bark</p> <p><b>F02</b> nero<br/>black</p> |
|--|--|--|---|---|







## viking K

VK01

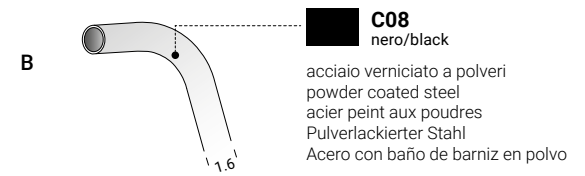
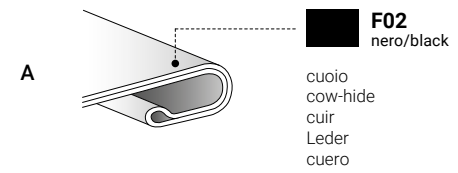
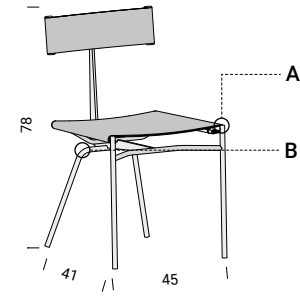

collection info  
pg. 230











## viking W

VK02

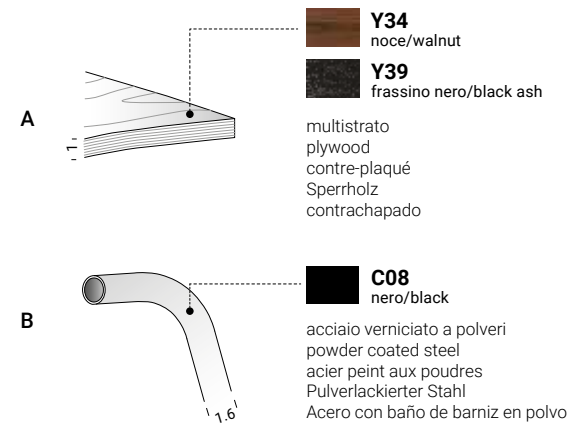
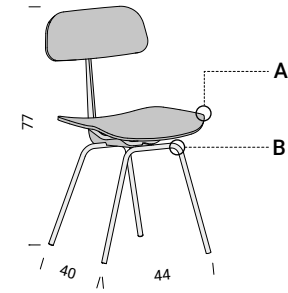

collection info  
pg. 230





## viking L

VK03

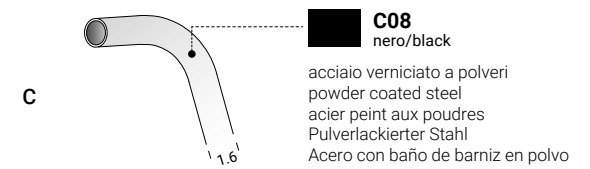
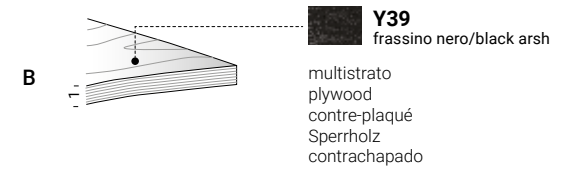
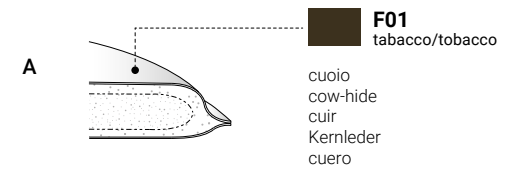
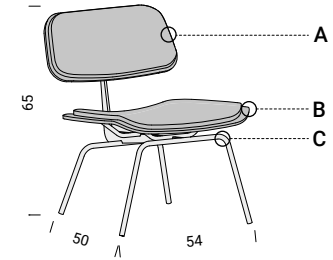

collection info  
pg. 230







## viking GL

VK04

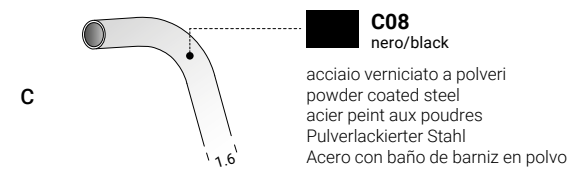
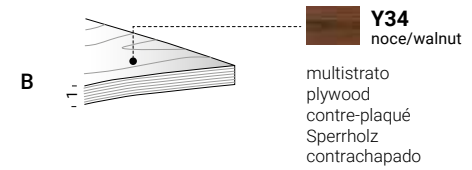
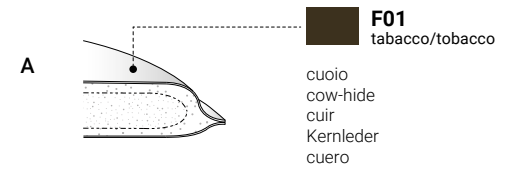
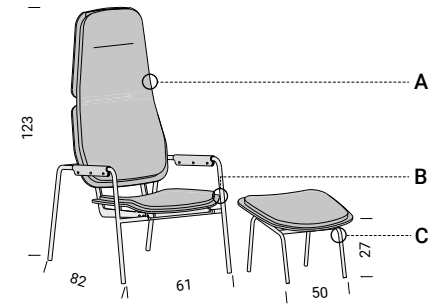

collection info  
pg. 230







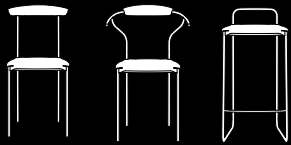

# danske C

**L'acciaio e il legno vengono plasmati esaltando le loro caratteristiche strutturali ed estetiche. Le singole geometrie tridimensionali di legno e acciaio si compenetrano in uniche superfici. Le parti in legno massiccio sono protette con vernice all'acqua opaca antigraffio, mentre le parti in acciaio sono verniciate a polveri.**

Steel and wood are shaped to emphasise their structural and aesthetic characteristics. The individual, three-dimensional geometries of the wood and steel permeate in single surfaces. The solid wood parts are protected with matt, scratch-proof water-based varnish, while the steel parts are powder painted.

L'acier et le bois sont façonnés en exaltant leurs caractéristiques structurelles et esthétiques. Les différentes géométries tridimensionnelles du bois et de l'acier s'interpénètrent en surfaces uniques. Les parties en bois massif sont protégées avec du vernis à l'eau opaque résistant aux rayures, alors que les parties en acier sont vernies par poudres.

Stahl und Holz sind so geformt, dass ihre strukturellen und ästhetischen Eigenschaften unterstrichen werden. Die einzelnen, dreidimensionalen Formen von Holz und Stahl durchdringen zusammen zu einzigen Oberflächen. Die Teile aus Massivholz sind mit einer Schicht aus mattem und kratzfesten Wasserlack geschützt und die Teile aus Stahl sind pulverlackiert.

El acero y la madera se modelan exaltando sus características estructurales y estéticas. Las geometrías tridimensionales individuales de la madera y el acero se compenetran en superficies únicas. Las piezas de madera maciza están protegidas con barniz mate al agua resistente a los arañazos, mientras que las piezas de acero están tratadas con barniz en polvo.



## materiali / materials



legno massiccio  
solid wood  
bois massif  
Massivholz  
madera maciza



acciaio  
steel  
acier  
Stahl  
acero

Le materie prime che costituiscono il sistema danske C derivano da un processo di riutilizzo e sono a loro volta riciclabili.

The primary materials used in the system danske C are sourced from a reuse process, and are in turn recyclable.

Les matières premières qui composent le système danske C dérivent d'un processus de réutilisation et sont à leur tour recyclables.

Die Rohstoffe für das System danske C entstammen einem Wiederverwertungsprozess und sind Ihrerseits wiederum recyclebar.

Las materias primas que constituyen el sistema danske C proceden de un proceso de reutilización y son, a su vez, reciclables.

sedie/ chairs / chaises / Stühle / sillas

C1

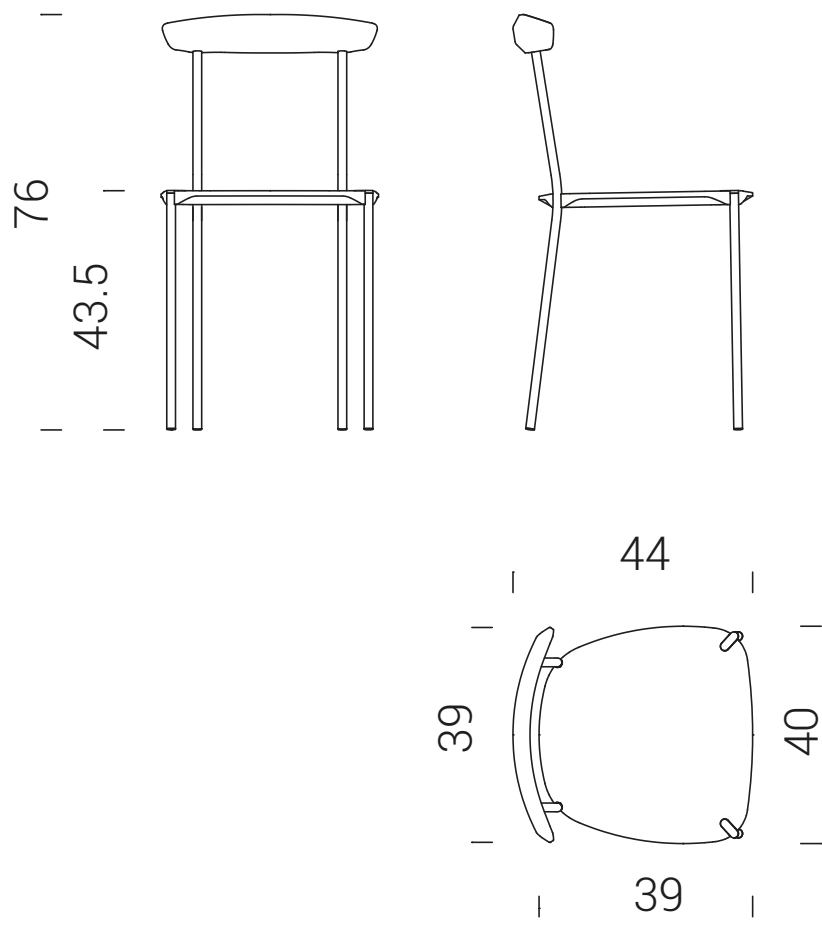

C2

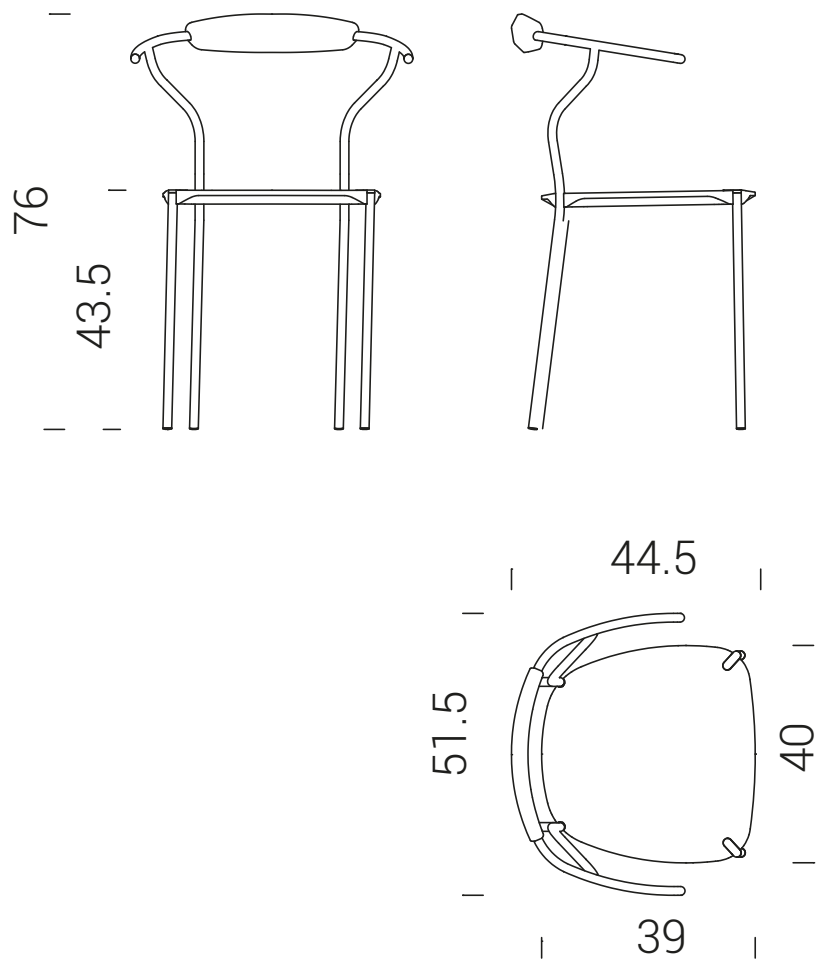

C3

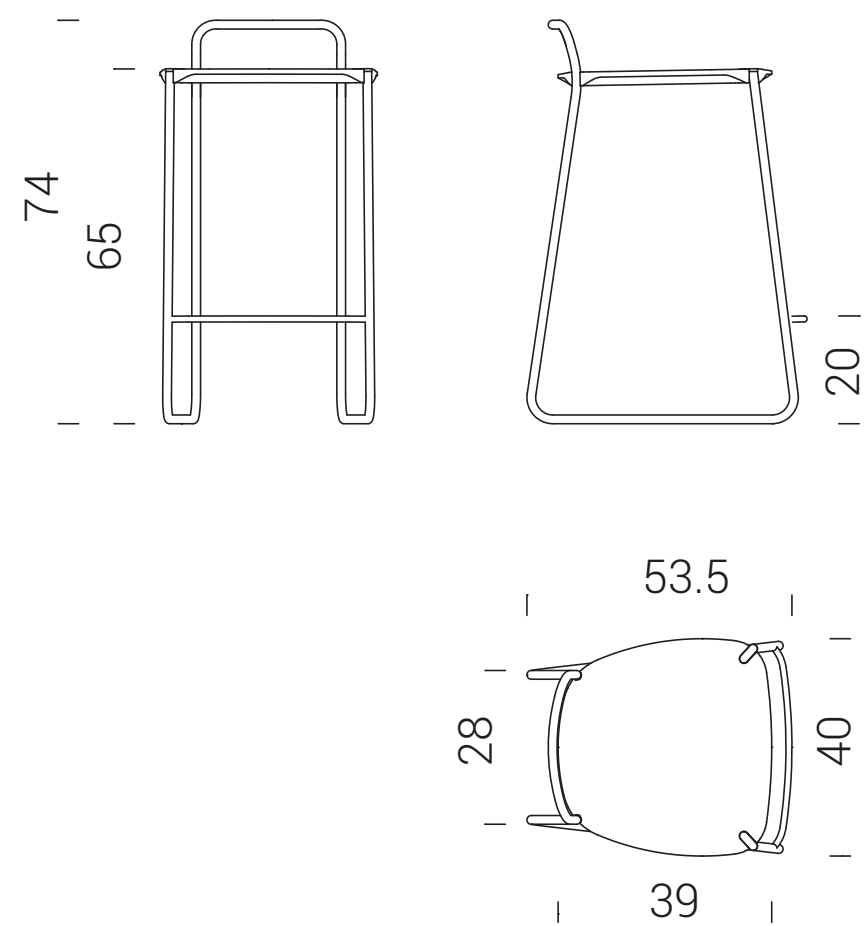

**fondello e schienale / seat and back / siège et dossier / Sitzfläche und Rückenlehne / asiento y respaldo**

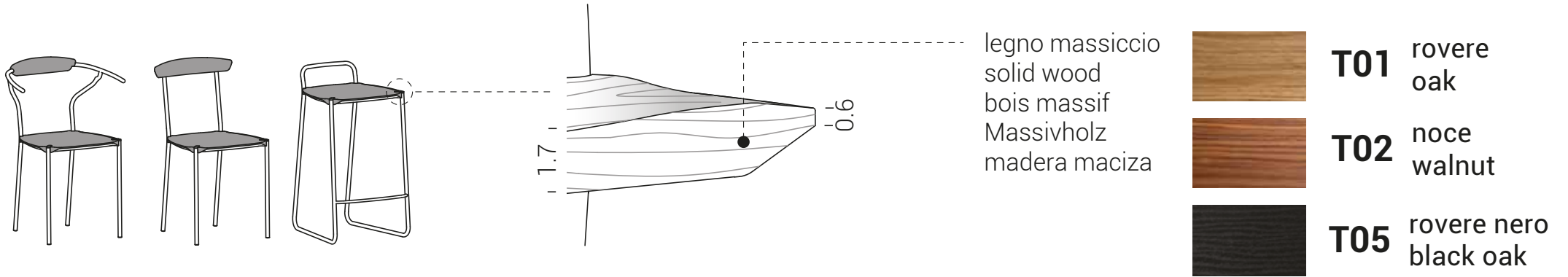

**telaio / structure / châssis / Gestell / bastidor**

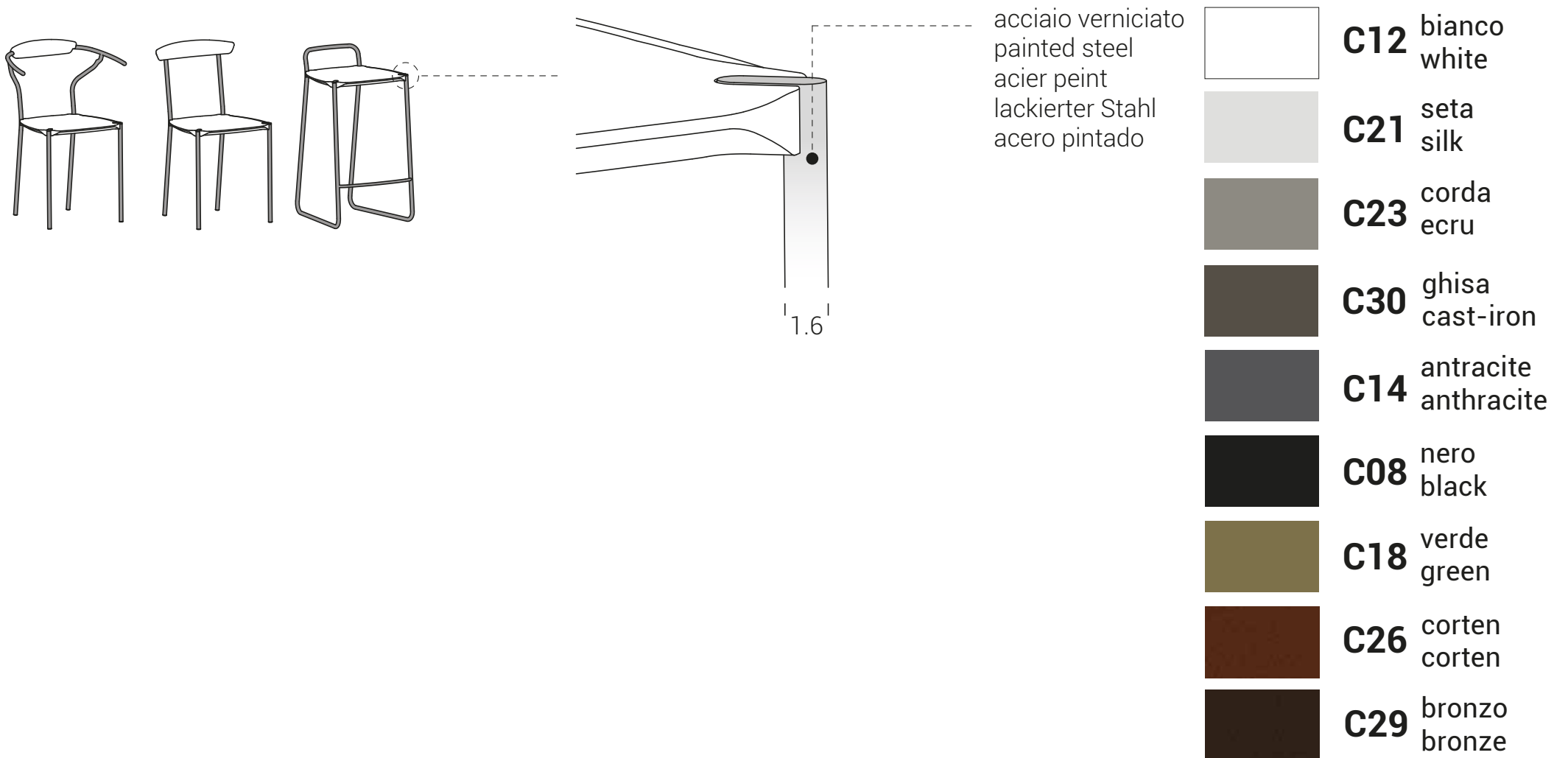







## danske C1

DC01

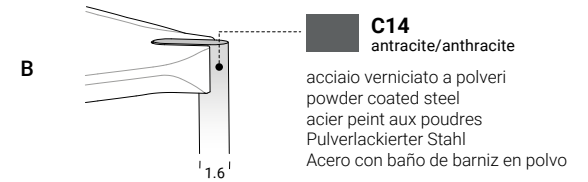
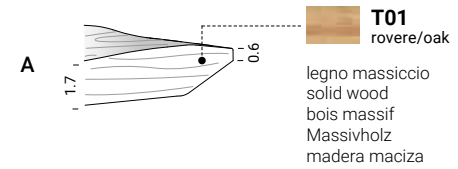
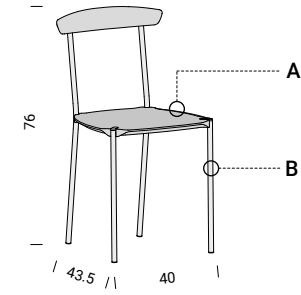

collection info  
pg. 244





## danske C2

DC02

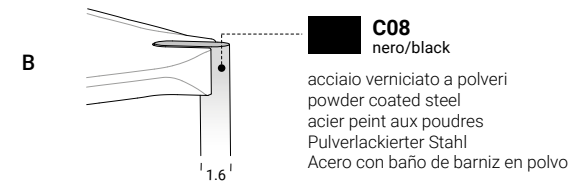
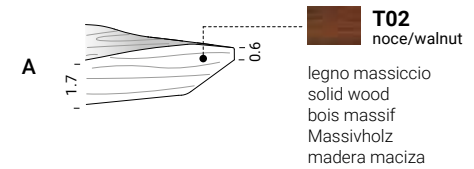
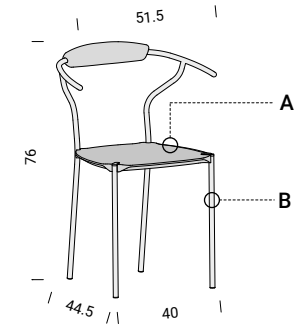

collection info  
pg. 244











## danske C3

DC04

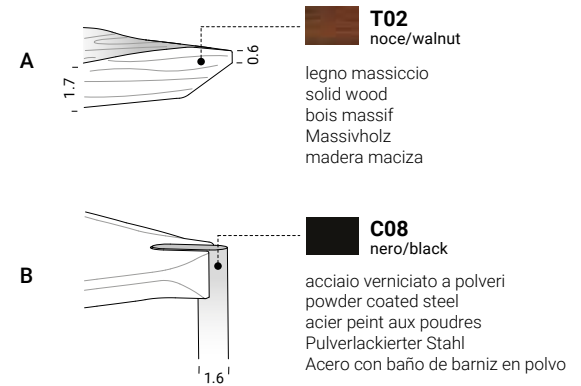
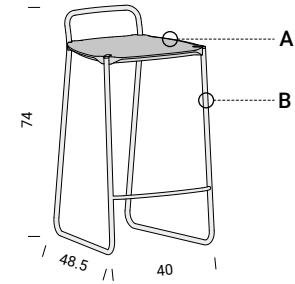

collection info  
pg. 244







## danske C3

DC03

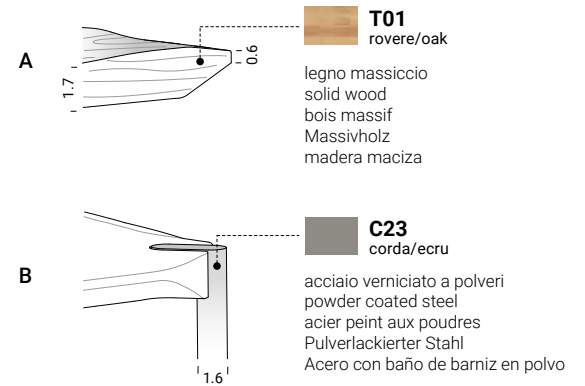
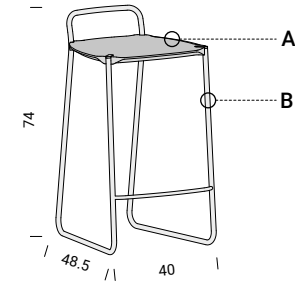

collection info  
pg. 244

# multimedia

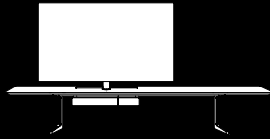

**connect**

pg. 258

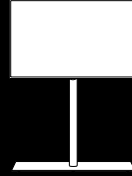

**spin360**

pg. 272

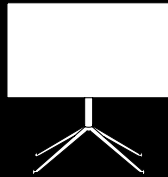

**apollo**

pg. 226

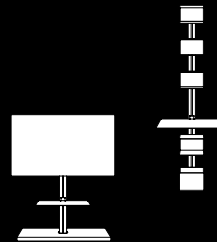

**girogiro-system**

pg. 278



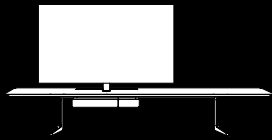

# connect

**Supporto pensato per installare le Tv di nuova generazione a parete o in centro stanza con la massima flessibilità. Il sistema di integrazione cavi studiato da extendo consente di nascondere completamente i cavi lasciando libertà di rotazione di 360° della Tv. Il supporto rotante e il contenimento di apparati multimediali nella parte sottostante sono accessori.**

This is a TV support column designed to host new generation TV installations either mounted on the wall or in the centre of the room with the utmost flexibility. The cable integration system designed by extendo makes it possible to completely conceal cables enabling the TV to freely rotate a full 360°. The turntable swivel base and the multimedia device cable containment system in the lower part of the support column are accessories.

Support conçu pour installer les téléviseurs de nouvelle génération au mur ou au centre de la pièce avec une flexibilité maximale. Le système d'intégration des câbles, conçu par extendo, permet de cacher complètement les câbles en laissant la liberté de rotation de 360° du téléviseur. Le support pivotant et le récipient pour appareils multimédias dans la partie en dessous sont des accessoires.

Fernsehhalterung für die Installation von TV-Geräten der neuesten Generation an der Wand oder in der Raummitte, für maximale Flexibilität bei der Positionierung. Dank der von extendo entwickelten, integrierten Kabelführung lassen sich die Gerätekabel völlig verstecken, wobei das Gerät um 360 Grad schwenkbar bleibt. Die Drehhalterung und die unterhalb anzubringenden Fächer für Multimedia-Geräte sind als Zubehör erhältlich.

Soporte pensado para instalar televisores de nueva generación en la pared o en una posición central en el ambiente, con la máxima flexibilidad. El sistema de integración de cables estudiado por extendo, permite ocultar los cables por completo, dejando libertad de rotación de 360° para el televisor. Cuenta con accesorios en la parte de abajo: un soporte giratorio y un espacio para posicionar dispositivos multimedia.



i cavi della TV e di eventuali unità multimediali sono completamente nascosti.  
the TV and multimedia unit wires are completely hidden.  
les fils de la TV et des unités multimédias sont complètement dissimulés.  
Die Kabel des Fernsehers und der Multimedia sind vollkommen unsichtbar.  
los cables de la TV y de los sistemas multimedia quedan completamente ocultos.

supporto monitor universale per TV da 19 a 65 pollici.  
universal monitor support for TV from 19 to 65 inches.  
support moniteur universel pour TV de 19 à 65 pouces.  
Universal-Monitor-Halter für TV von 19 bis 65 Zoll.  
soporte de monitor universal para TV de 19 a 65 pulgadas.

## materiali / materials



HPL+legno  
HPL+wood  
HPL+bois  
HPL+Holz  
HPL+madera



legno massiccio  
solid wood  
bois massif  
Massivholz  
madera maciza

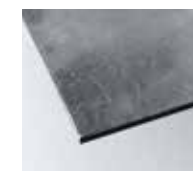

acciaio  
steel  
acier  
Stahl  
acero

Le materie prime che costituiscono il sistema connect derivano da un processo di riutilizzo e sono a loro volta riciclabili.

The primary materials used in the system connect are sourced from a reuse process, and are in turn recyclable.

Les matières premières qui composent le système connect dérivent d'un processus de réutilisation et sont à leur tour recyclables.

Die Rohstoffe für das System connect entstammen einem Wiederverwertungsprozess und sind ihrerseits wiederum recyclebar.

Las materias primas que constituyen el sistema connect proceden de un proceso de reutilización y son, a su vez, reciclables.



panca porta TV / bench TV support / banc TV / Fernsehbank / banco de TV

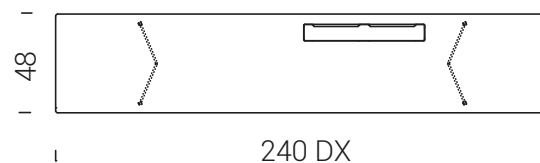
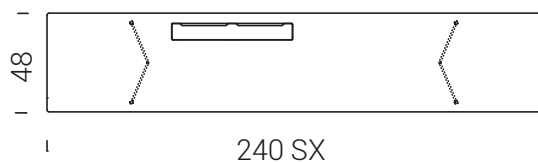
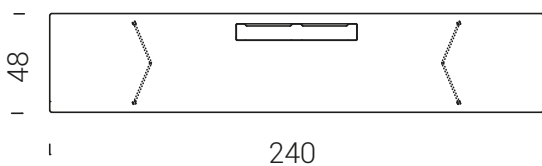
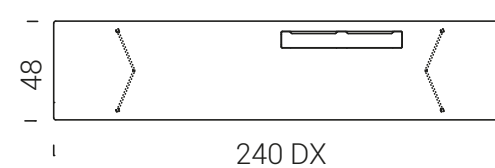
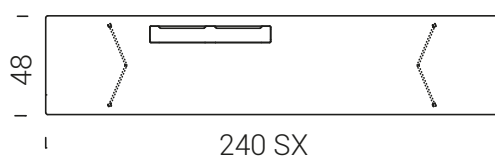
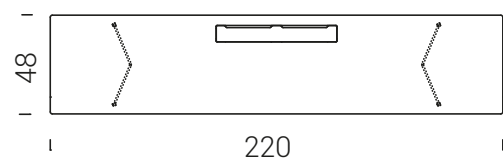
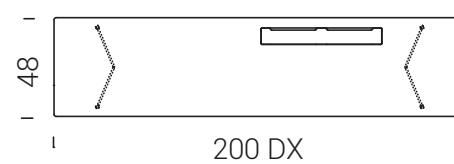
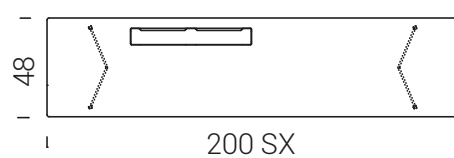
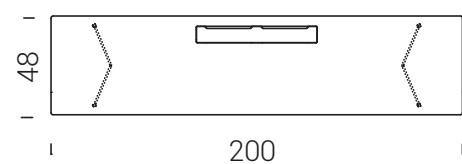
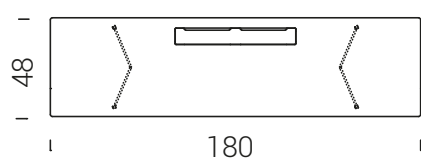
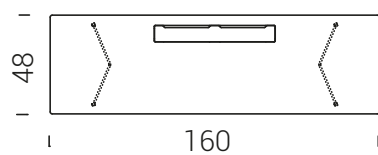
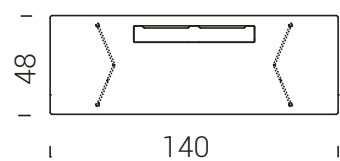
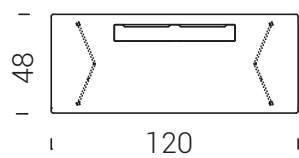

accessori / accessories / accessoires / Zubehör / accesorios

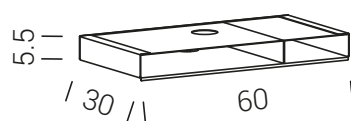
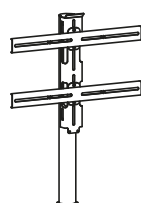
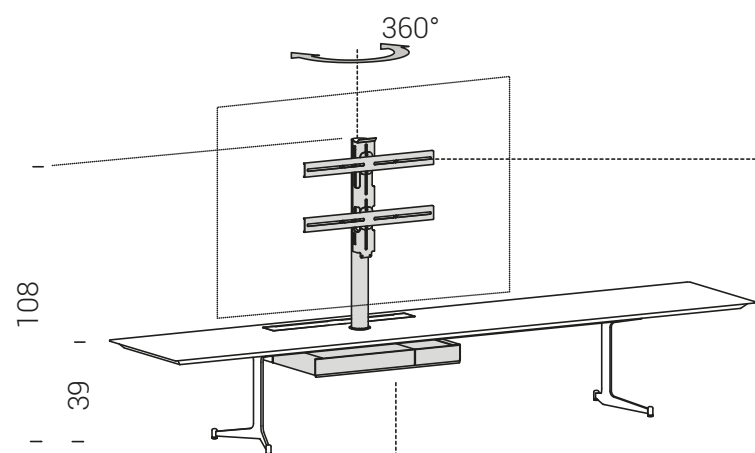

+

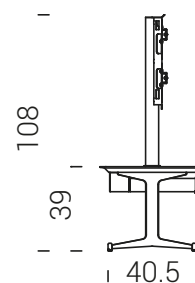
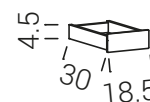
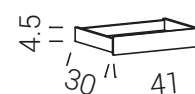

top / top / plateaux / Platte / plano

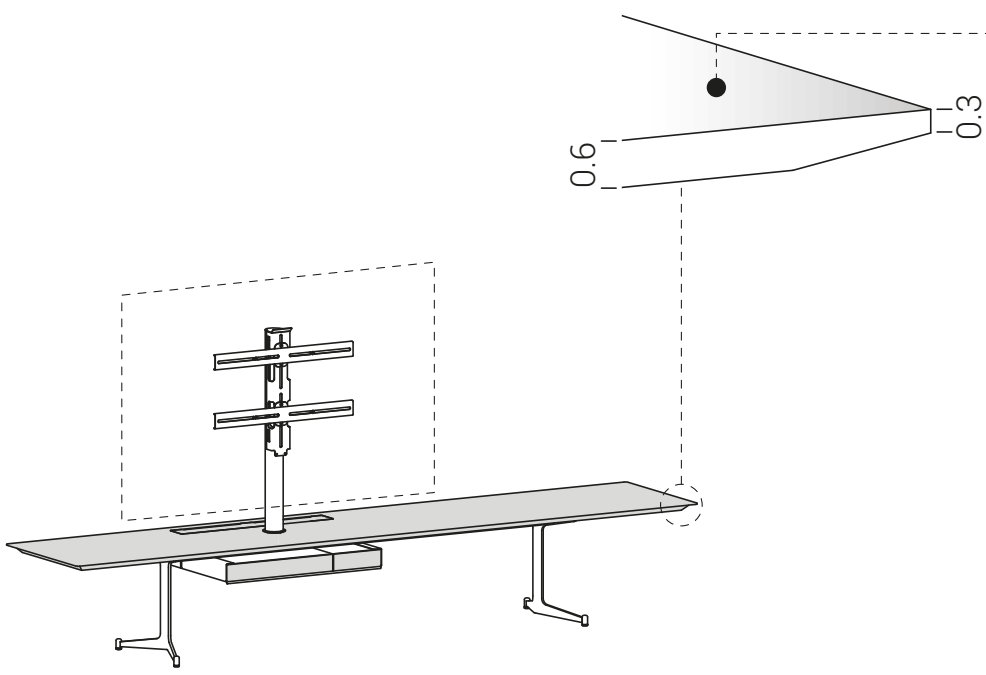

HPL



**L03** bianco  
white

Fenix®



**L08** grigio Londra  
London grey



**L06** nero  
black

HPL + legno  
wood  
bois  
Holz  
madera



**Y36** rovere  
oak



**Y34** noce  
walnut



**Y37** rovere affumicato  
smoked oak



**Y39** frassino nero  
black arsh

HPL + metallo  
metal  
métal  
Metall  
metal



**C31** ottone  
brass



**C32** ottone scuro  
dark brass



**C35** inox  
inox



**C36** inox scuro  
dark inox

HPL + ecotouch



**N01** sabbia  
sand



**N02** basalto  
basalt

HPL + cemento  
concrete  
ciment  
zement  
cemento



**D01** bianco calce  
lime white



**D02** grigio Portland  
Portland grey

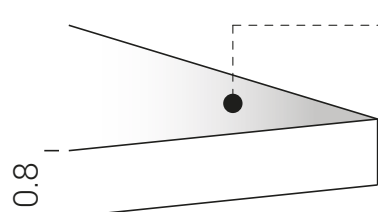

calcestruzzo  
beton  
béton  
Beton  
hormigón



**H01** quarzo  
quartz



**H02** arenaria  
brownstone



**H03** grafite  
graphite

HPL + pietra naturale  
natural stone  
pierre naturelle  
Naturstein  
piedra natural



**P01** grigio cenere  
ash grey



**P02** nero ardesia  
slate black

telaio / structure/ châssis / Gestell / bastidor

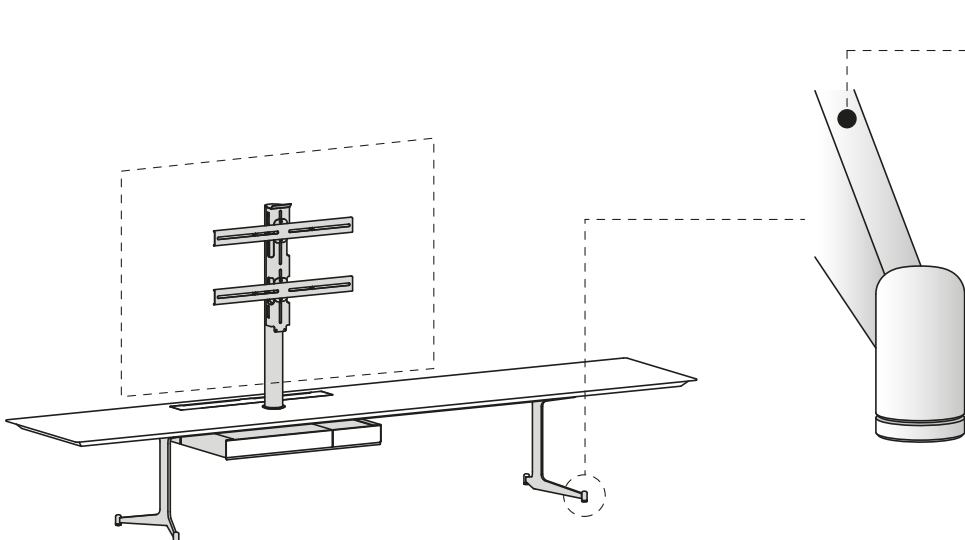

acciaio verniciato  
painted steel  
acier peint  
lackierter Stahl  
acero pintado



**C12** bianco  
white



**C21** seta  
silk



**C23** corda  
ecru



**C30** ghisa  
cast-iron



**C14** antracite  
anthracite

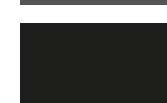

**C08** nero  
black



**C18** verde  
green



**C26** corten  
corten



**C29** bronzo  
bronze





## connect CN01

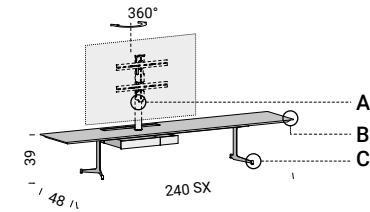

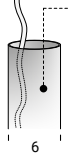
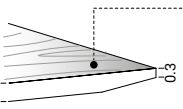
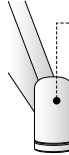
- A**
- 
- C08**  
nero/black
- acciaio verniciato a polveri  
powder coated steel  
acier peint aux poudres  
Pulverlackierter Stahl  
Acero con baño de barniz en polvo
- B**
- 
- Y39**  
frassino nero/black ash
- HPL impiallacciato  
veneered HPL  
HPL plaqué  
HPL mit Furnier  
HPL chapado
- C**
- 
- C08**  
nero/black
- acciaio verniciato a polveri  
powder coated steel  
acier peint aux poudres  
Pulverlackierter Stahl  
Acero con baño de barniz en polvo

collection info  
pg. 258











## connect CN02

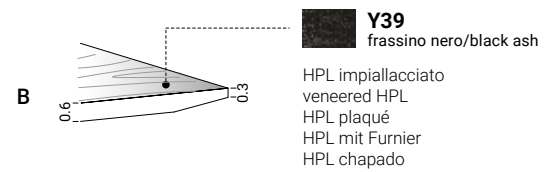
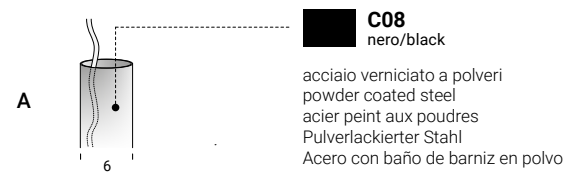
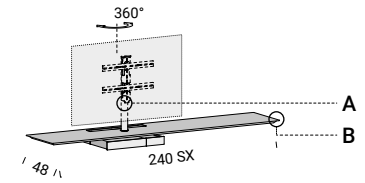

collection info  
pg. 258





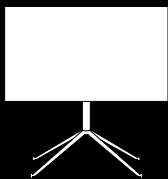

# apollo

**Desideravamo disegnare un supporto che si integrasse al meglio con il design essenziale degli ultimi modelli Tv. Apollo pur essendo composto da pochi elementi che ne evidenziano la purezza geometrica, consente la rotazione di 360°, l'occultamento dei cavi e la possibilità di aggiungere accessori porta decoder e sound bar.**

We had the intention to design a TV support column that integrates at best with the essential design of the latest TV models. Although Apollo consists of only a few elements that enhance its geometrical purity, it rotates 360°, the concealing of cables along with the possibility to add TV decoder and sound bar support accessories.

Nous souhaitons dessiner un support qui s'intègre au mieux avec le design essentiel des derniers modèles de téléviseurs. Apollo, même s'il est composé de peu d'éléments qui mettent en évidence sa pureté géométrique, permet la rotation de 360°, la dissimulation des câbles et la possibilité d'ajouter des accessoires comme le porte-décodeur et la barre audio.

Unser Anliegen bestand darin, einen Fernsehständer zu entwerfen, der optimal auf das essentielle Design der neuesten TV-Modelle abgestimmt ist. Apollo setzt auf einen essentiellen Aufbau aus wenigen Elementen und besticht durch eine schlichte Optik. Er erlaubt eine Drehung des Geräts um 360 Grad, bietet unsichtbare Kabelverlegung und auf Wunsch zusätzliche Ablagen für Decoder und Soundbar als Zubehör.

Nuestro deseo era diseñar un soporte que se integrara de la mejor forma con el diseño esencial de los últimos modelos de televisores. Apollo, que consta de pocos elementos que ponen de relieve su pureza geométrica, permite la rotación de 360°, ocultar los cables y la posibilidad de añadir accesorios porta codificador y barra de sonido.

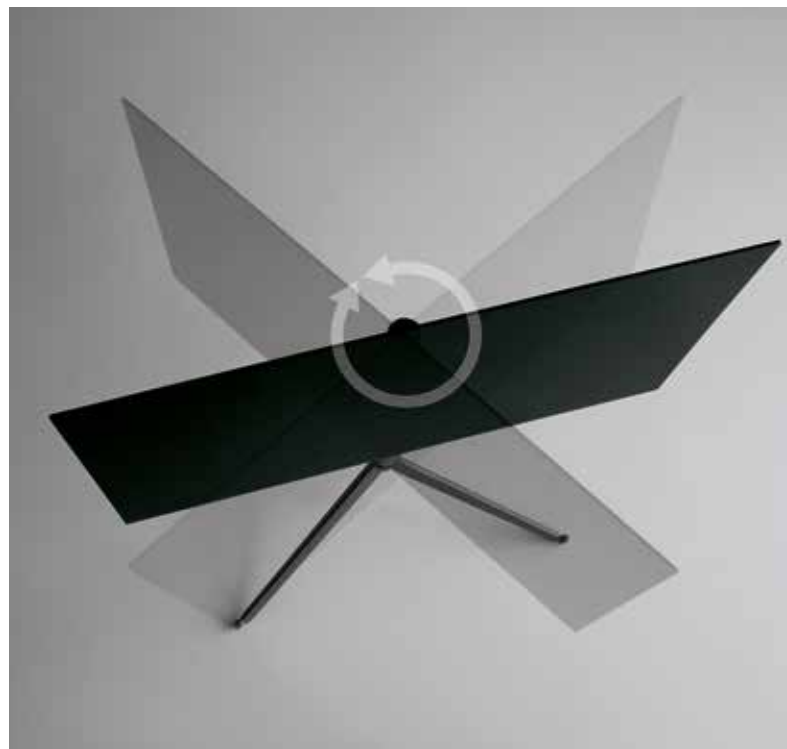

i cavi della TV e di eventuali unità multimediali sono completamente nascosti.  
the TV and multimedia unit wires are completely hidden.  
les fils de la TV et des unités multimédias sont complètement dissimulés.  
Die Kabel des Fernsehers und der Multimedia sind vollkommen unsichtbar.  
los cables de la TV y de los sistemas multimedia quedan completamente ocultos.



supporto monitor universale per TV da 19 a 65 pollici.  
universal monitor support for TV from 19 to 65 inches.  
support moniteur universel pour TV de 19 à 65 pouces.  
Universal-Monitor-Halter für TV von 19 bis 65 Zoll.  
soporte de monitor universal para TV de 19 a 65 pulgadas.

## materiali / materials

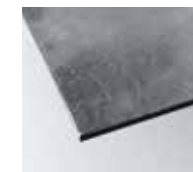

acciaio  
steel  
acier  
Stahl  
acero

Le materie prime che costituiscono il sistema apollo derivano da un processo di riutilizzo e sono a loro volta riciclabili.

The primary materials used in the system apollo are sourced from a reuse process, and are in turn recyclable.

Les matières premières qui composent le système apollo dérivent d'un processus de réutilisation et sont à leur tour recyclables.

Die Rohstoffe für das System apollo entstammen einem Wiederverwertungsprozess und sind Ihrerseits wiederum recyclebar.

Las materias primas que constituyen el sistema apollo proceden de un proceso de reutilización y son, a su vez, reciclables.

porta TV / TV support / porte TV / Fernsehstand / soporte TV

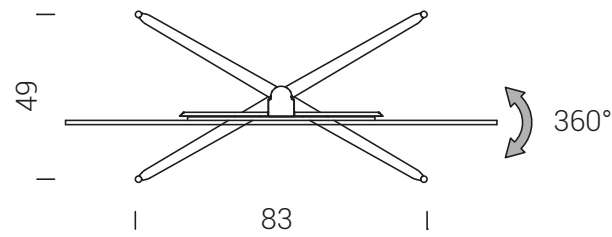
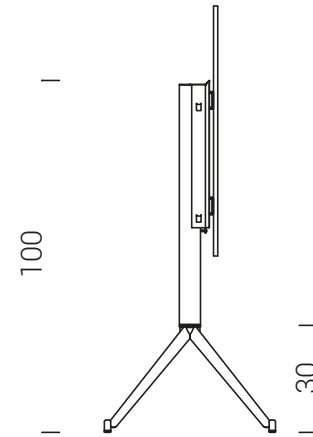
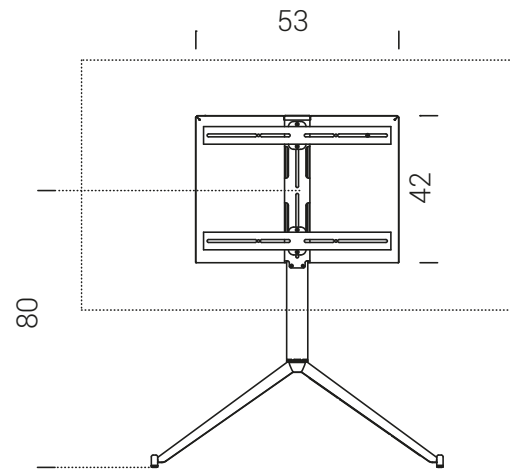
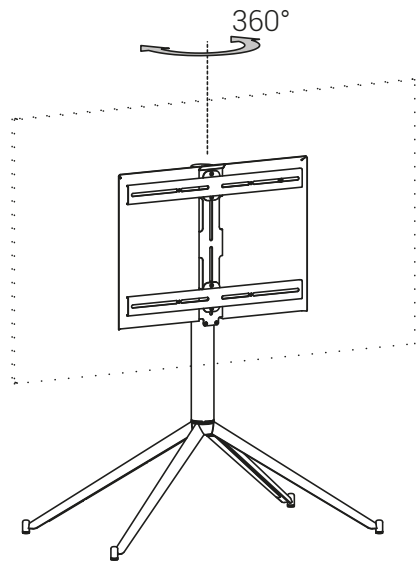

accessori / accessories / accessoires / Zubehör / accesorios

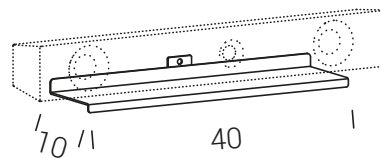
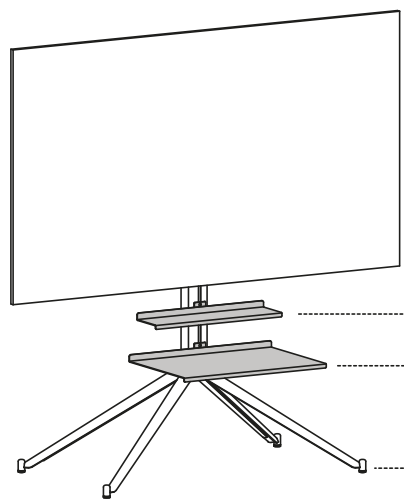

porta soundbar / soundbar support  
support barre de son / Soundbar-Halter  
soporte barra de sonido

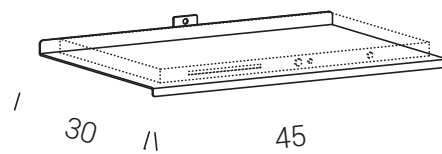

porta dvd-player / dvd-player shelf  
étagère porte-lecteur dvd / Boden für DVD-player  
estante porta dvd

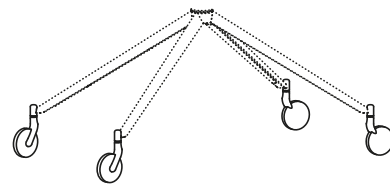

ruote / castors  
roues / Rädern  
ruedas

telaio / structure / châssis / Gestell / bastidor

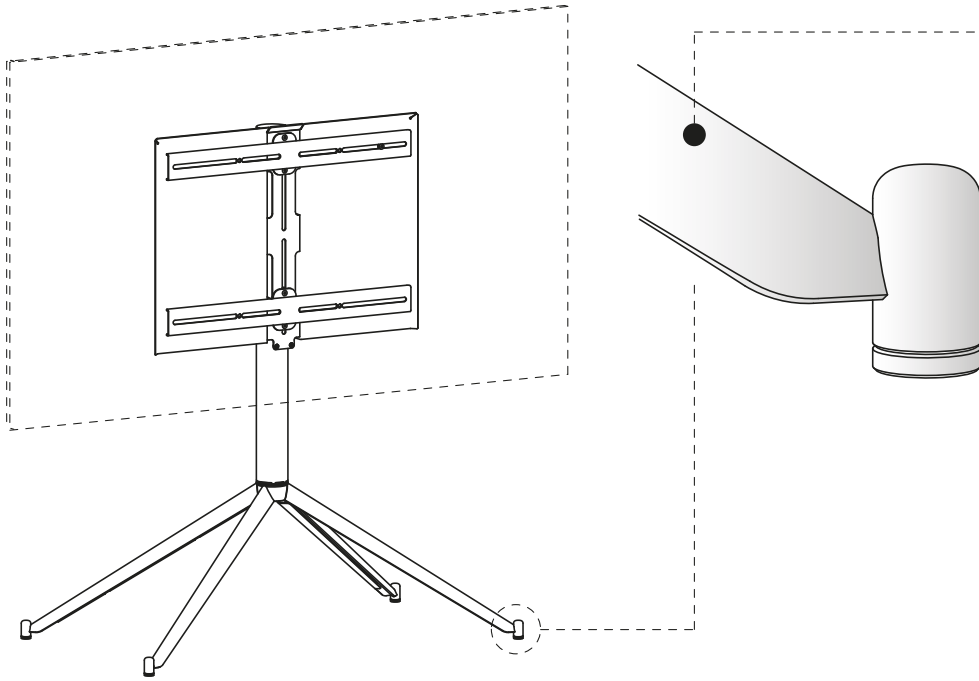

acciaio verniciato  
painted steel  
acier peint  
lackierter Stahl  
acero pintado



**C12** bianco  
white

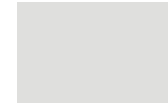

**C21** seta  
silk



**C23** corda  
ecru



**C30** ghisa  
cast-iron



**C14** antracite  
anthracite



**C08** nero  
black







**apollo**  
AP02

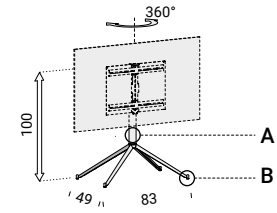

**A**

**C14**  
antracite/anthracite

acciaio verniciato a polveri  
powder coated steel  
acier peint aux poudres  
Pulverlackierter Stahl  
Acero con baño de barniz en polvo

**B**

**C14**  
antracite/anthracite

acciaio verniciato a polveri  
powder coated steel  
acier peint aux poudres  
Pulverlackierter Stahl  
Acero con baño de barniz en polvo

collection info  
pg. 266





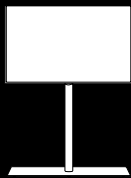

# spin360

**Spin 360 è un supporto TV disegnato e progettato per una perfetta integrazione con i monitor dal design più sofisticato. Nascondere i cavi completamente al suo interno e orientare la colonna a 360 gradi, garantisce massima funzionalità e purezza di disegno. Spin 360 è disponibile nella versione con base in acciaio spessore 6mm, con contenitore per unità multimediali aperto o chiuso, in due altezze distinte H=100 / 120 cm, (altezze nel punto medio del monitor).**

Spin 360 is a TV support designed and manufactured for perfect integration with the most sophisticated monitor designs. It completely hides wires within and the column can be turned 360 degrees, guaranteeing maximum functionality and clean design. Spin 360 is available in a version with a 6mm thick steel base, with a container for multimedia units opened or closed, in two distinct heights H=100 / 120 cm, (heights at average height of the monitor).

Spin 360 est un support pour TV dessiné et conçu pour une intégration parfaite avec les écrans aux designs les plus sophistiqués. Pour un maximum de fonctionnalité et de pureté du dessin dissimuler les fils complètement à l'intérieur et orienter la colonne à 360°. Spin 360 est disponible dans la version avec base en acier, épaisseur 6 mm, avec module de rangement pour unités multimédias ouvert ou fermé, disponible dans deux hauteurs distinctes H=100/120 cm, (hauteurs mesurées au point médian de l'écran).

Spin 360 ist ein TV-Halter, der für eine perfekte Integration von hoch entwickelten Bildschirmen entworfen wurde. Die vollständige Unterbringung der Kabel im Halter und die Drehmöglichkeit der Säule um 360 Grad, bieten höchste Zweckmäßigkeit und ein klares Design. Spin 360 ist in der Version mit einem Fuß aus 6 mm starkem Stahl, einer multimedialen, offenen oder geschlossenen Einheit, in zwei unterschiedlichen Höhen von 100 oder 120 cm (Höhe des Mittelpunktes des Bildschirms) erhältlich.

Spin 360 es un soporte de TV diseñado y desarrollado para una integración perfecta con la pantalla de diseño más sofisticado. Ocultar los cables completamente en su interior y orientar la columna a 360 grados, garantiza la máxima durabilidad y la pureza del diseño. Spin 360 está disponible en versión con base de acero de 6 mm de grosor, con compartimento para sistemas multimedia abierto o cerrado, en dos alturas diferentes H = 100/120 cm, (altura desde el punto central de la pantalla).



la base è dotata di pattini in teflon per un facile spostamento.  
the base is equipped with Teflon slides for easy movement.  
la base est munie de patins en téflon afin de faciliter le déplacement.  
Für eine einfache Verschiebung ist die Basis mit Teflon-Kufen ausgestattet.  
la base cuenta con patines de teflón para colocarla fácilmente.

i cavi della TV e di eventuali unità multimediali sono completamente nascosti.  
the TV and multimedia unit wires are completely hidden.  
les fils de la TV et des unités multimédias sont complètement dissimulés.  
Die Kabel des Fernsehers und der Multimedia sind vollkommen unsichtbar.  
los cables de la TV y de los sistemas multimedia quedan completamente ocultos.

supporto monitor universale per TV da 19 a 65 pollici.  
universal monitor support for TV from 19 to 65 inches.  
support moniteur universel pour TV de 19 à 65 pouces.  
Universal-Monitor-Halter für TV von 19 bis 65 Zoll.  
soporte de monitor universal para TV de 19 a 65 pulgadas.

## materiali / materials

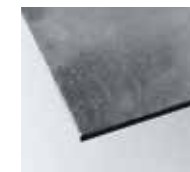

acciaio  
steel  
acier  
Stahl  
acero

Le materie prime che costituiscono il sistema spin360 derivano da un processo di riutilizzo e sono a loro volta riciclabili.

The primary materials used in the system spin360 are sourced from a reuse process, and are in turn recyclable.

Les matières premières qui composent le système spin360 dérivent d'un processus de réutilisation et sont à leur tour recyclables.

Die Rohstoffe für das System spin360 entstammen einem Wiederverwertungsprozess und sind ihrerseits wiederum recyclebar.

Las materias primas que constituyen el sistema spin360 proceden de un proceso de reutilización y son, a su vez, reciclables.



porta TV / TV support / porte TV / Fernsehstand / soporte TV

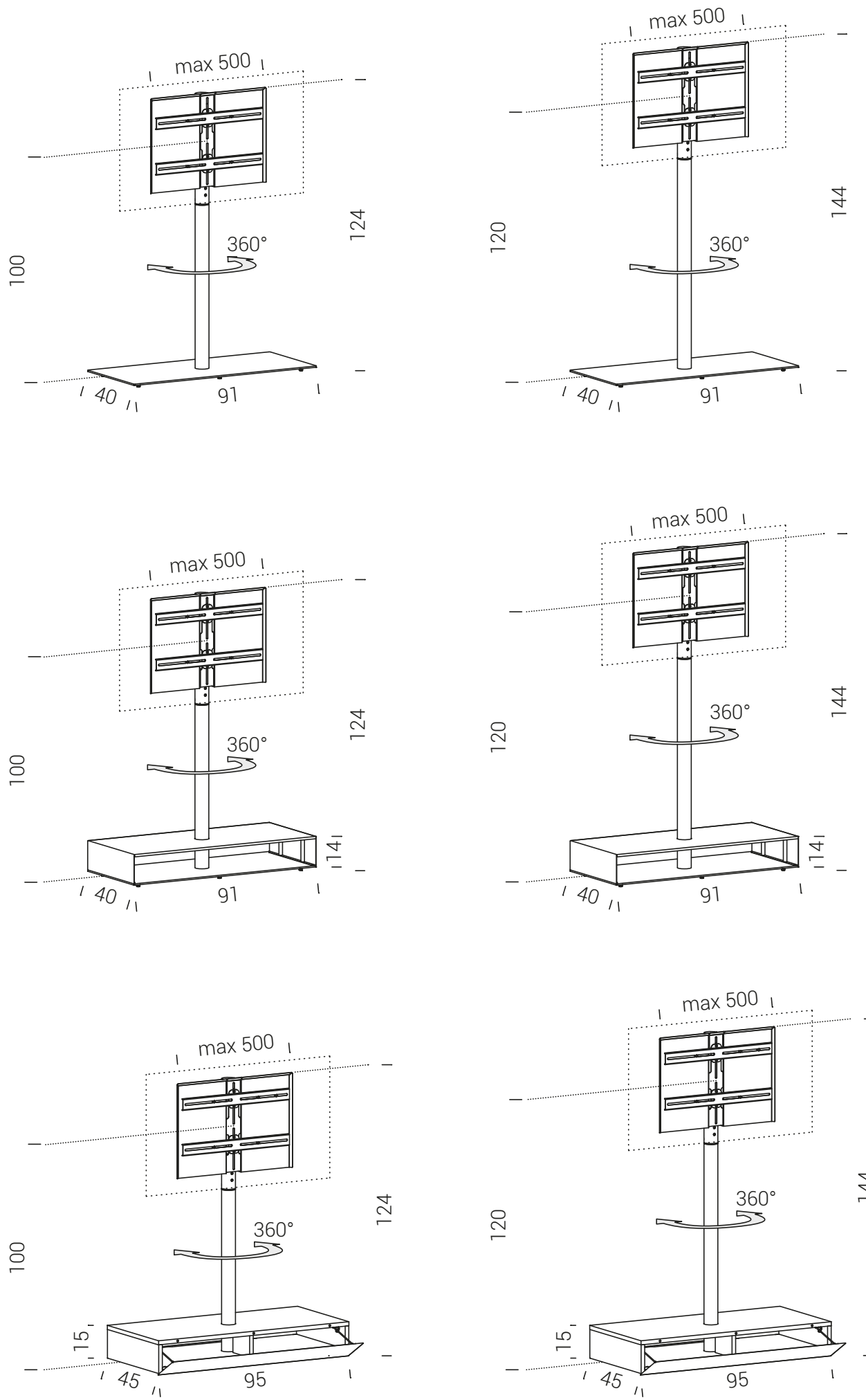

accessori / accessories / accessoires / Zubehör / accesorios

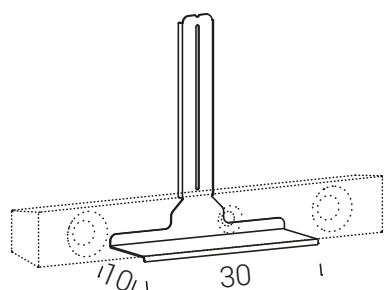

porta soundbar  
 soundbar support  
 support barre de son  
 Soundbar-Halter  
 soporte barra de sonido

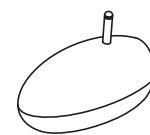





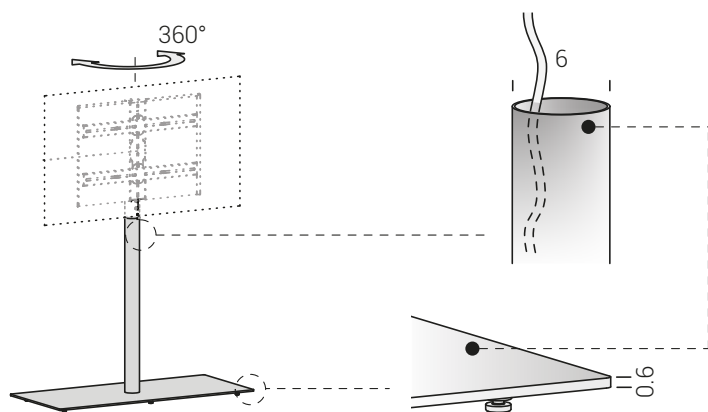







ripetitore di segnale per telecomandi  
 signal relay for remote control  
 répéteur de signal pour télécommandes  
 Signalverstärker für Fernsteuerung  
 repetidor de señal para mando a distancia

telaio / structure / châssis / Gestell / bastidor



acciaio verniciato  
 painted steel  
 acier peint  
 lackierter Stahl  
 acero pintado

-  **C12** bianco white
-  **C21** seta silk
-  **C23** corda ecru
-  **C30** ghisa cast-iron
-  **C14** antracite anthracite
-  **C08** nero black

-  **C12** bianco white
-  **C21** seta silk
-  **C23** corda ecru
-  **C30** ghisa cast-iron
-  **C14** antracite anthracite
-  **C08** nero black

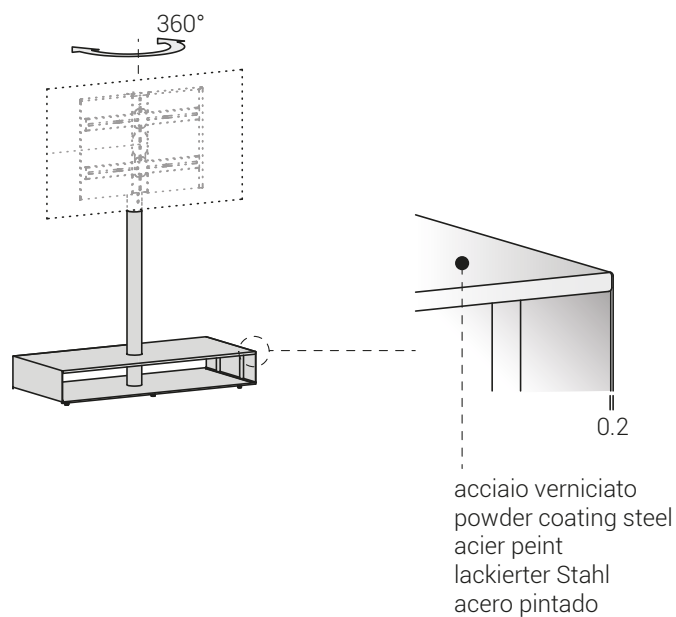

acciaio verniciato  
 powder coating steel  
 acier peint  
 lackierter Stahl  
 acero pintado

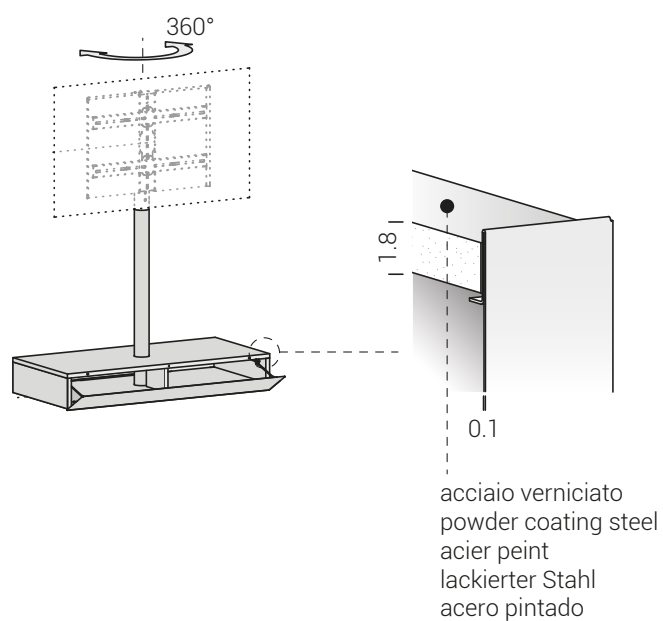

acciaio verniciato  
 powder coating steel  
 acier peint  
 lackierter Stahl  
 acero pintado





## spin360

SN01

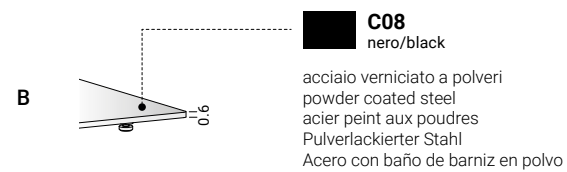
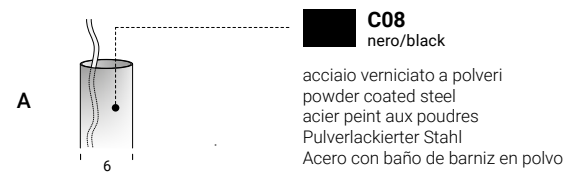
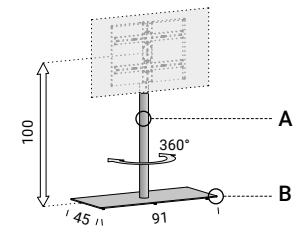

collection info  
pg. 272







La copertura in acciaio a rimozione rapida, consente di nascondere nella parte posteriore del monitor, cavi e prese. Il supporto regolabile per sound bar è un accessorio utilizzabile nei 6 modelli porta TV.

The fast-removal steel covering allows the rear part of the monitor, cables and sockets to be easily hidden. The adjustable support for the sound bar is an accessory used in the 6 TV support models.

La couverture en acier à démontage rapide, permet de dissimuler les fils et les prises à l'arrière de l'écran. Le support réglable pour barre de son est un accessoire utilisable avec les 6 modèles porte TV.

Die einfach zu entfernende Stahlabdeckung ermöglicht die sichtgeschützte Unterbringung der Kabel und Stecker an der Rückseite des Bildschirms. Der einstellbare Sound Bar-Halter kann bei den 6 Modellen für TV-Halter eingesetzt werden.

La cubierta de acero de extracción rápida permite ocultar, por detrás de la pantalla, cables y tomas. El soporte ajustable para la barra de sonido es un accesorio utilizable en los 6 modelos de soporte de TV.



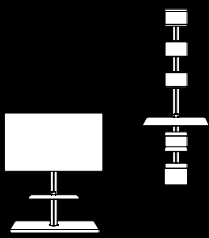

# girogiro-system

**Le colonne girogiro con base 40x40 sono accessoriabili con elementi porta libri, riviste, CD. La versione girogiro con base 80x40, l'asta telescopica extendo e il profilo a parete extendo, sono prodotti accessoriabili con staffa supporto monitor universale, ripiani per unità multimediali, ripiani per libri, riviste, DVD, CD. Le clip ferma-cavi in dotazione con la staffa monitor consentono di effettuare il cablaggio all'esterno del profilo.**

The girogiro columns with a 40x40 base can be accessorised with book, magazine and CD shelving elements. The girogiro version with an 80x40 base, the Extendo telescopic pole and Extendo wall profile are products easily accessorised with a universal monitor support bracket, shelving for multimedia units or shelving for books, magazines, DVDs and CDs. The cable-tie clips supplied with the monitor bracket enable wiring outside the profile.

Les colonnes girogiro avec base 40x40 peuvent être équipées avec des éléments porte-livres, revues, CD. La version girogiro avec base 80x40, la tige télescopique extendo et le profilé mural extendo sont des produits pouvant être équipés de fixation de support de moniteur universel, d'étagères pour unités multimédia, d'étagères pour livres, revues, DVD, CD. Le clip serre-câble fourni avec la fixation de support de moniteur permet d'effectuer le câblage à l'extérieur du profilé.

Die Säulen girogiro mit einem 40x40 Fuß können mit Halter für Bücher, Zeitschriften, CDs ausgestattet werden. Die Version girogiro mit Fuß 80x40, die extendo Teleskopstange und das extendo Wandprofil, können mit Universal-Monitor-Halter, Fächer für multimediale Geräte, Fächer für Bücher, Zeitschriften, DVD und CD ausgestattet werden. Die zusammen mit dem Monitorhalter gelieferte Kabelklemmen ermöglichen die Verkabelung an der Außenseite des Profils.

Las columnas girogiro con base de 40 x 40 se pueden equipar con elementos de almacenamiento de libros, revistas y CD. La versión girogiro con base de 80 x 40, la barra telescópica extendo y el perfil de sujeción a pared extendo son productos equipables con accesorios como el soporte de monitor universal o los estantes para libros, revistas, DVD o CD. El clip sujetacables que viene con el soporte de monitor permite efectuar el cableado por fuera del perfil.



## materiali / materials



alluminio  
aluminium  
Aluminium  
aluminio



acciaio  
steel  
acier  
Stahl  
acero

Le materie prime che costituiscono il sistema girogiro-system derivano da un processo di riutilizzo e sono a loro volta riciclabili.

The primary materials used in the system girogiro-system are sourced from a reuse process, and are in turn recyclable.

Les matières premières qui composent le système girogiro-system dérivent d'un processus de réutilisation et sont à leur tour recyclables.

Die Rohstoffe für das System girogiro-system entstammen einem Wiederverwertungsprozess und sind ihrerseits wiederum recyclebar.

Las materias primas que constituyen el sistema girogiro-system proceden de un proceso de reutilización y son, a su vez, reciclables.

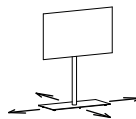

la base è dotata di pattini in teflon per un facile spostamento.  
the base is equipped with Teflon slides for easy movement.  
la base est munie de patins en téflon afin de faciliter le déplacement.  
Für eine einfache Verschiebung ist die Basis mit Teflon-Kufen ausgestattet.  
la base cuenta con patines de teflón para colocarla fácilmente.



i cavi della TV e di eventuali unità multimediali sono completamente nascosti.  
the TV and multimedia unit wires are completely hidden.  
les fils de la TV et des unités multimédias sont complètement dissimulés.  
Die Kabel des Fernsehers und der Multimedia sind vollkommen unsichtbar.  
los cables de la TV y de los sistemas multimedia quedan completamente ocultos.



supporto monitor universale per TV da 19 a 65 pollici.  
universal monitor support for TV from 19 to 65 inches.  
support moniteur universel pour TV de 19 à 65 pouces.  
Universal-Monitor-Halter für TV von 19 bis 65 Zoll.  
soporte de monitor universal para TV de 19 a 65 pulgadas.

porta TV / TV support / porte TV / Fernsehstand / soporte TV  
girogiro 80x40

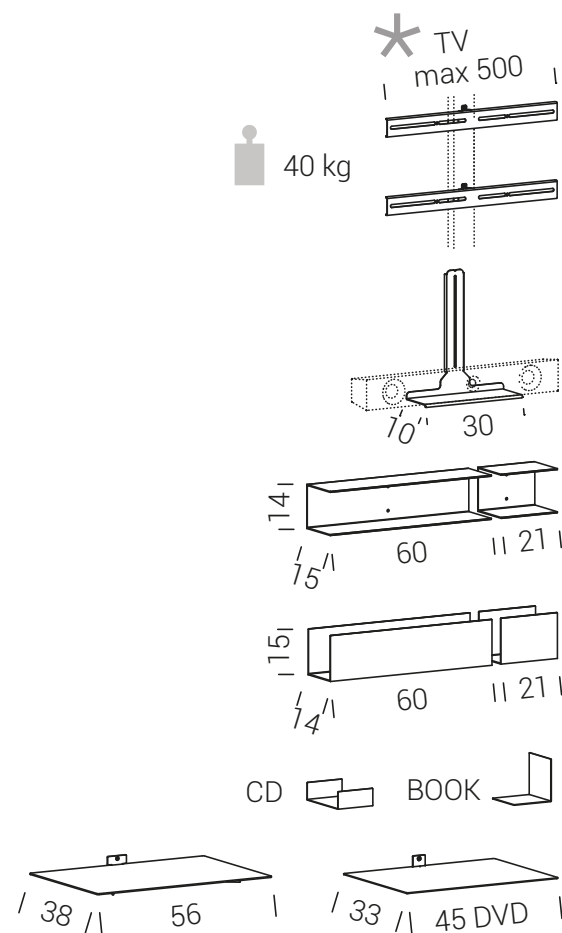
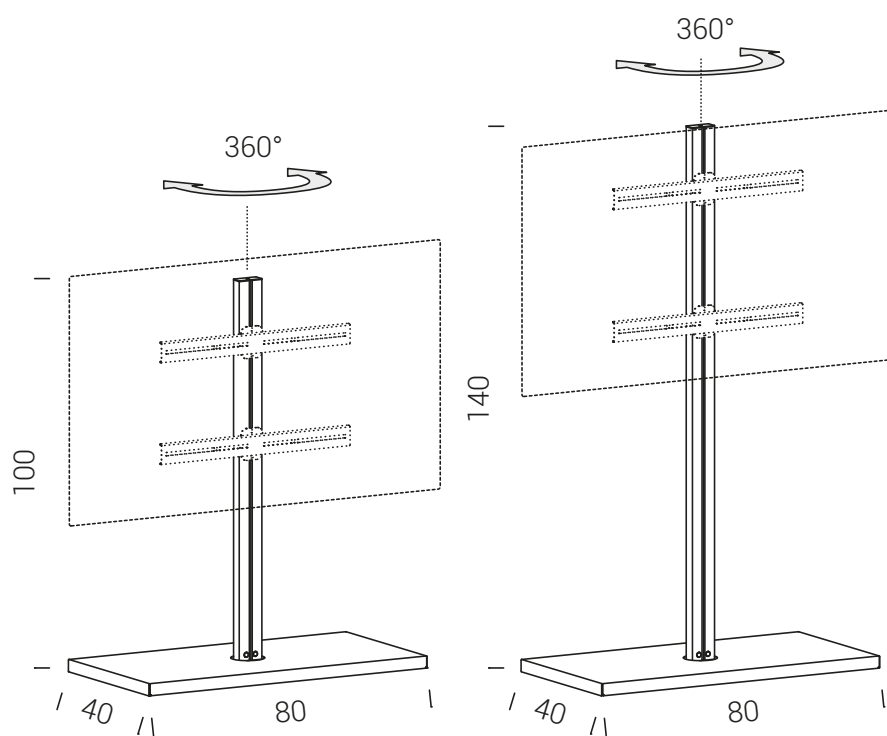

system

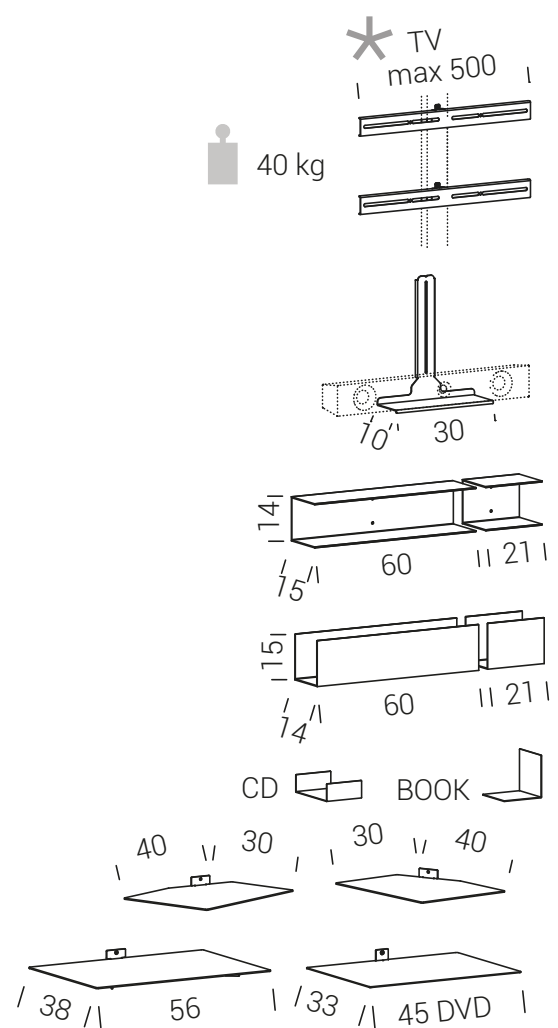
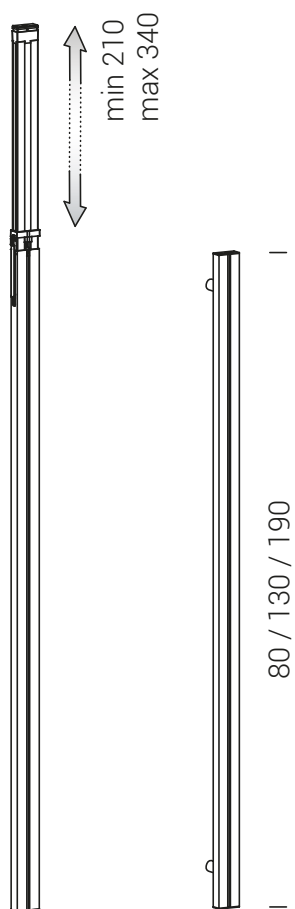



## telaio / structure / châssis / Gestell / bastidor

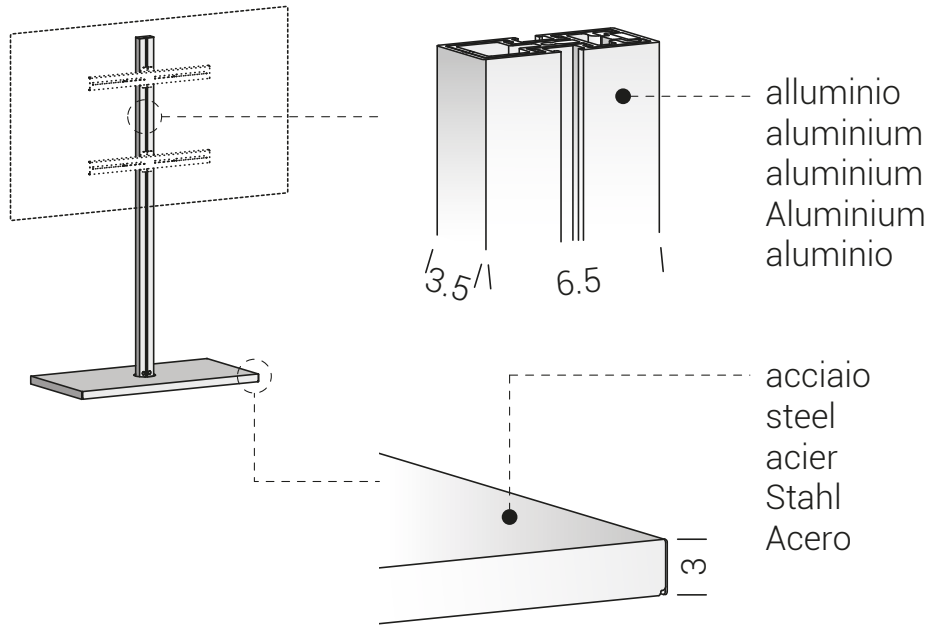

verniciatura a polveri  
powder coating  
peinture en poudres  
Pulverlackierung  
pintura en polvo



**C12** bianco  
white

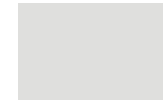

**C21** seta  
silk



**C30** ghisa  
cast-iron



**C08** nero  
black

## system

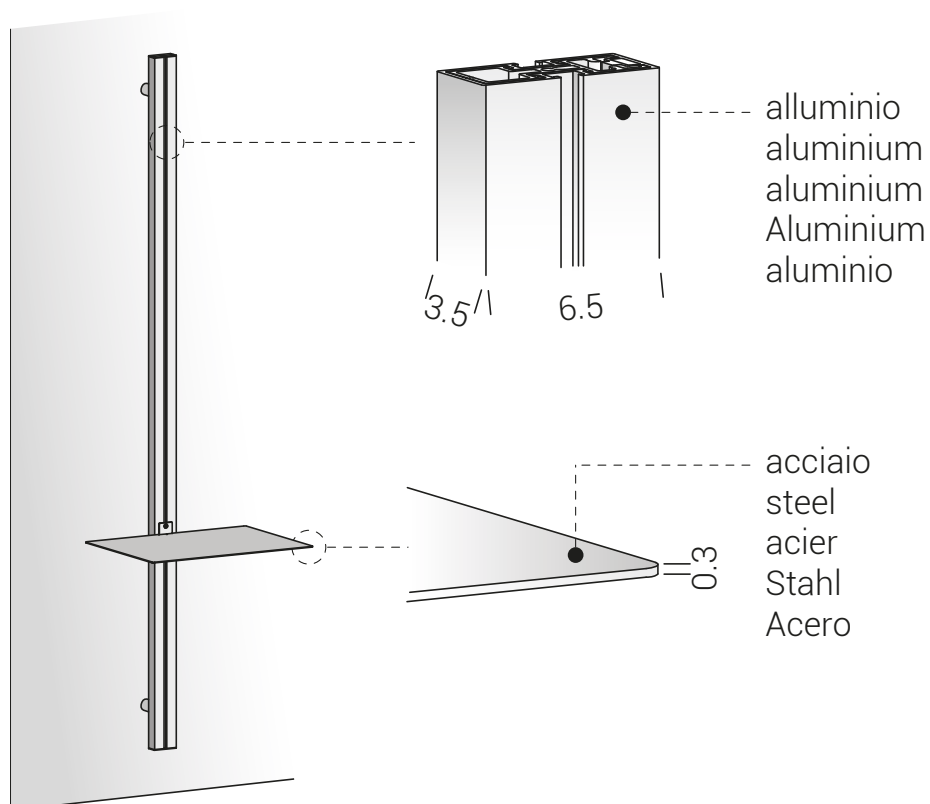

verniciatura a polveri  
powder coating  
peinture en poudres  
Pulverlackierung  
pintura en polvo



**C12** bianco  
white

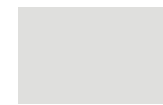

**C21** seta  
silk



**C30** ghisa  
cast-iron



**C08** nero  
black





**system**  
SY55

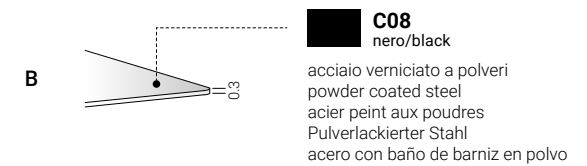
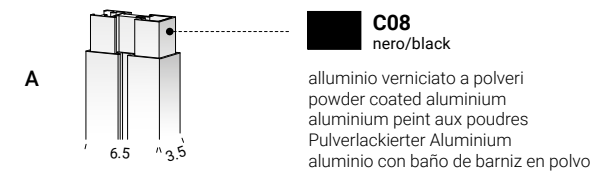
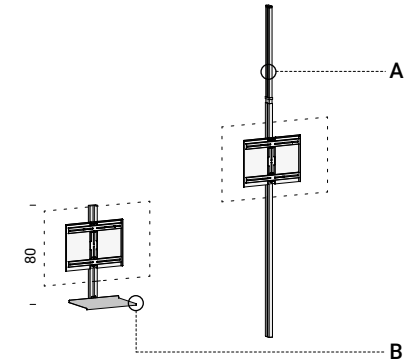

collection info  
pg. 278







**girogiro**  
SY20C

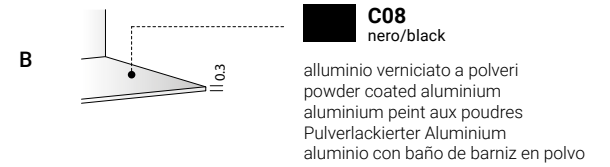
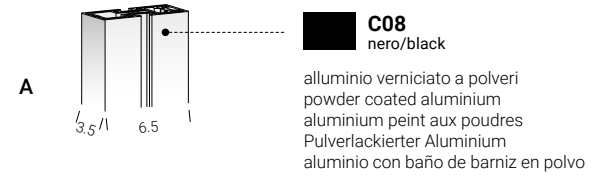
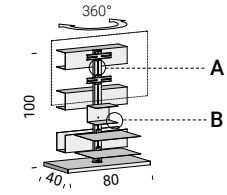

collection info  
pg. 278





## system SY23

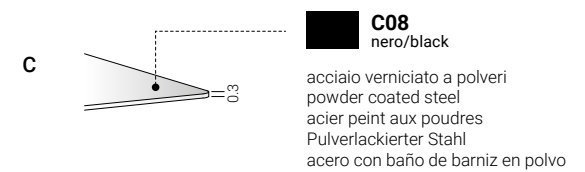
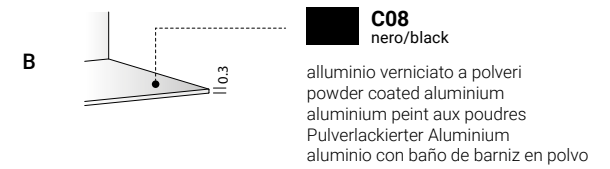
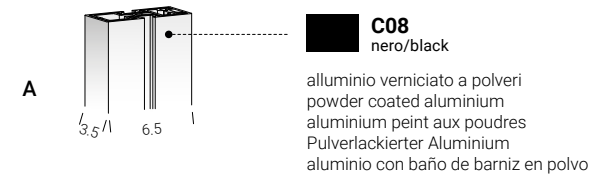
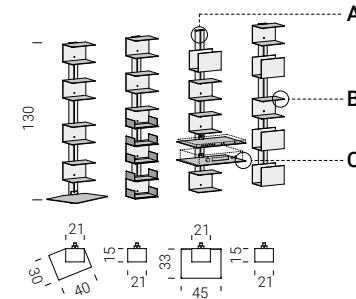

collection info  
pg. 278



## system SY18

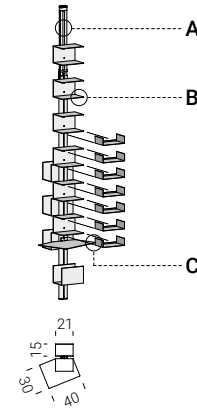

- A**
- 
- C08**  
nero/black
- alluminio verniciato a polveri  
powder coated aluminium  
aluminium peint aux poudres  
Pulverlackierter Aluminium  
aluminio con baño de barniz en polvo
- B**
- 
- C08**  
nero/black
- alluminio verniciato a polveri  
powder coated aluminium  
aluminium peint aux poudres  
Pulverlackierter Aluminium  
aluminio con baño de barniz en polvo
- C**
- 
- C08**  
nero/black
- acciaio verniciato a polveri  
powder coated steel  
acier peint aux poudres  
Pulverlackierter Stahl  
acero con baño de barniz en polvo

collection info  
pg. 278



## system SY17

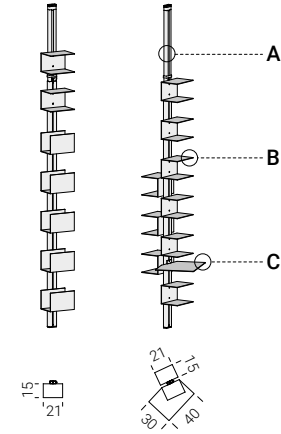

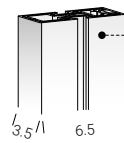
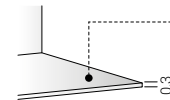
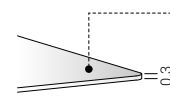
- A**
- 
- C12**  
bianco/white
- alluminio verniciato a polveri  
powder coated aluminium  
aluminium peint aux poudres  
Pulverlackierter Aluminium  
aluminio con baño de barniz en polvo
- B**
- 
- C12**  
bianco/white
- alluminio verniciato a polveri  
powder coated aluminium  
aluminium peint aux poudres  
Pulverlackierter Aluminium  
aluminio con baño de barniz en polvo
- C**
- 
- C12**  
bianco/white
- acciaio verniciato a polveri  
powder coated steel  
acier peint aux poudres  
Pulverlackierter Stahl  
acero con baño de barniz en polvo

collection info  
pg. 278



# walk in closet

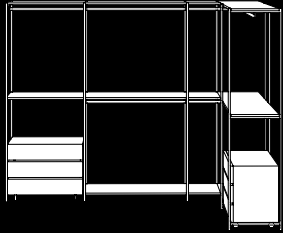

**slide**

pg. 290

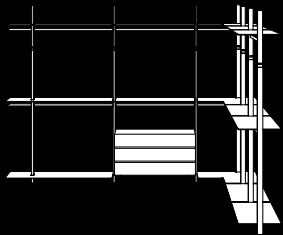

**personal**

pg. 306



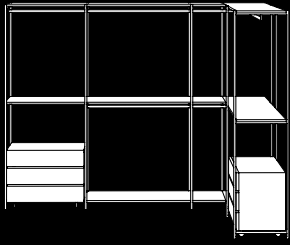

## slide

**Le coppie di profili verticali, i ripiani e le barre appenderia sono ordinabili al centimetro, ciò consente di progettare lo spazio desiderato in modo sartoriale senza extracosti di riduzioni.**

The pairs of upright profiles, the shelves and hanging rails can be sized to the centimetre, making it possible to design a tailor-made space without the added cost of reductions.

Les paires de profils verticaux, les étagères et les barres porte-vêtements peuvent être commandées au centimètre, ceci permet d'organiser l'espace souhaité « sur mesure » sans coûts supplémentaires de réduction.

Die Paare vertikaler Profile, die Böden und die Aufhängestangen können zentimetergenau bestellt werden. Dadurch kann der gewünschte Raum ohne zusätzliche Kosten für Kürzungen maßgeschneidert geplant werden.

Los pares de perfiles verticales, estantes y barras de colgar se pueden pedir por centímetros, lo que permite diseñar el espacio deseado adaptándolos sin costos adicionales de reducción.



## slide materials



alluminio  
aluminium  
Aluminium  
aluminio

Le materie prime che costituiscono il sistema slide derivano da un processo di riutilizzo e sono a loro volta riciclabili.

The primary materials used in the system slide are sourced from a reuse process, and are in turn recyclable.

Les matières premières qui composent le système slide dérivent d'un processus de réutilisation et sont à leur tour recyclables.

Die Rohstoffe für das System slide entstammen einem Wiederverwertungsprozess und sind Ihrerseits wiederum recyclebar.

Las materias primas que constituyen el sistema slide proceden de un proceso de reutilización y son, a su vez, reciclables.



Il sistema di ancoraggio a "pinza" tra ripiani e profili verticali consente in fase progettuale il loro libero posizionamento in orizzontale e verticale. E' disponibile anche una versione di barra appenderia in posizione "terminale" che consente di spostare orizzontalmente la coppia profili verticali in ogni momento.

The "pincer" anchoring system attaching shelves to upright profiles means that during the design stage they can be freely positioned horizontally and vertically. The hanging rail is also available in an end-position version, so that the pair of upright profiles can be moved horizontally at any time.

Le système de fixation par « pince » entre les étagères et les profils verticaux permet, en phase de conception, leur positionnement libre dans le sens horizontal et vertical. Une version de barre porte-vêtements est également disponible en position « terminale ». Elle permet de déplacer la paire de profils verticaux dans le sens horizontal à tout moment.

Mit dem „Klemmen“-Verankerungssystem zwischen Böden und vertikalen Profilen können die Elemente bei der Planung frei horizontal oder vertikal positioniert werden. Es ist auch eine Version mit Aufhängestange in "Endposition" erhältlich, bei der das Paar vertikaler Profile jederzeit verschoben werden kann.

El sistema de anclaje de "pinza" entre los estantes y los perfiles verticales permite su libre colocación en horizontal y vertical durante la fase de diseño. También hay una versión de barra de colgar en posición "terminal" que permite colocar horizontalmente el par de perfiles verticales en todo momento.

**spalle / support profiles / montants / Widerlage / perchas**

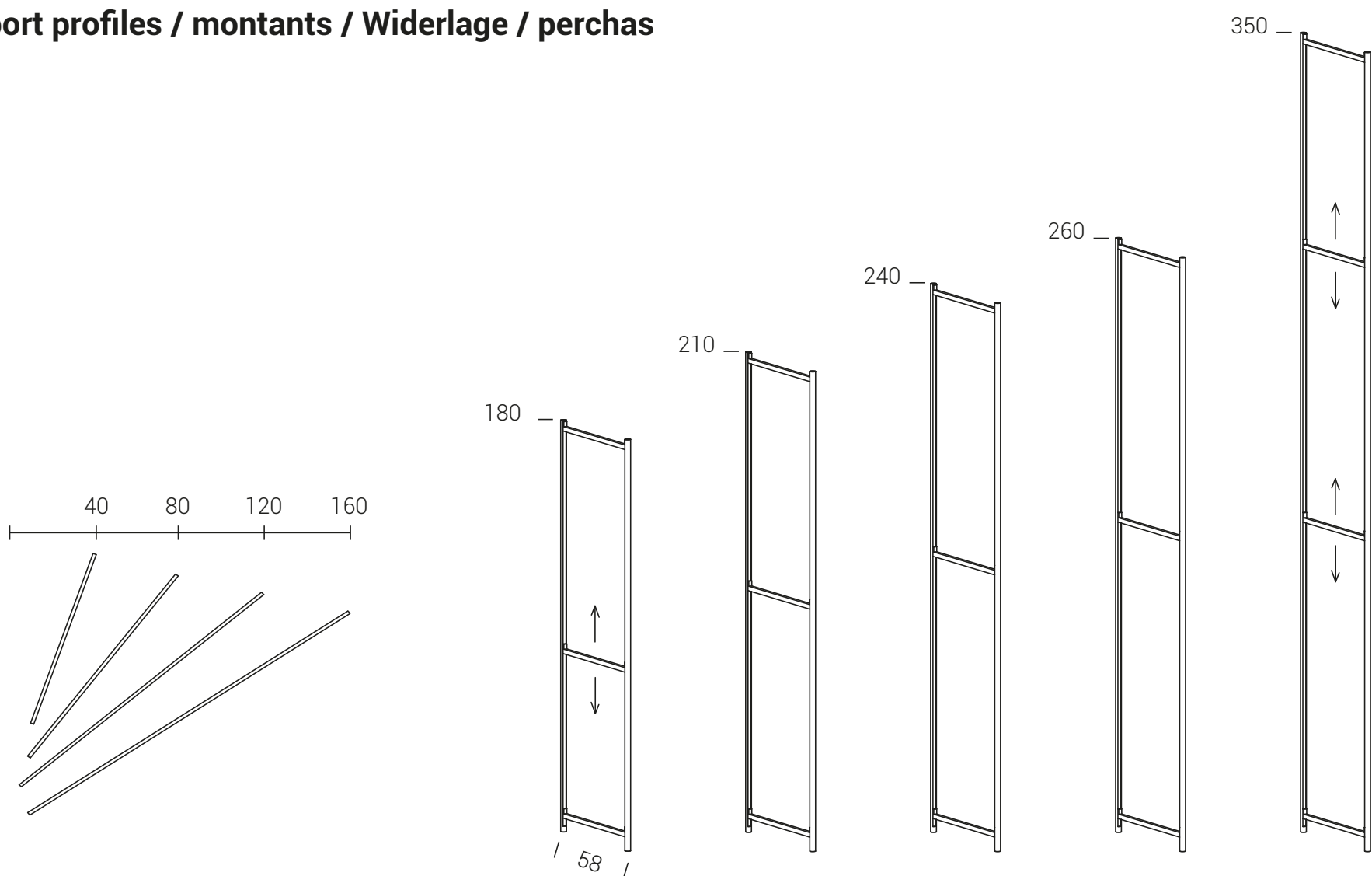

disponibili riduzioni a misura / tailor-made reduction available / disponibles réductions sur mesure  
 cm Verkleinerung nach Kundenwunsch / disponibles reducciones a medida

**ripiani / shelves / étagères / Böden / estantes**

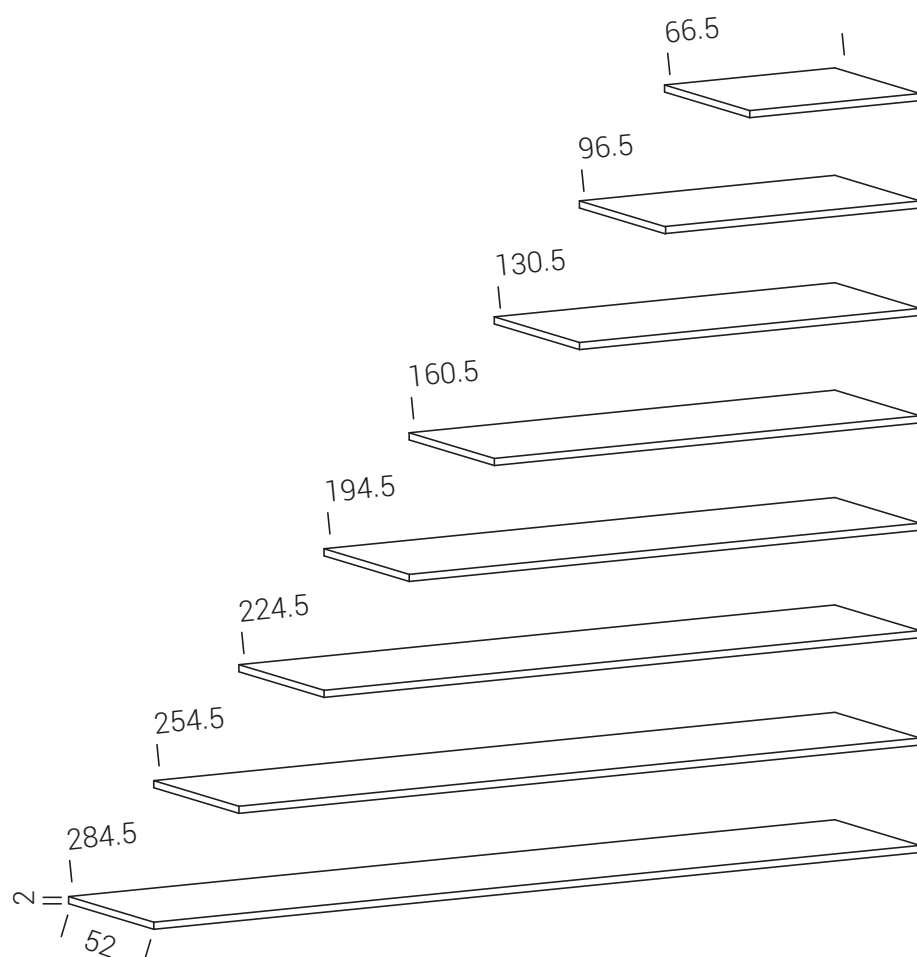

disponibili riduzioni a misura / tailor-made reduction available / disponibles réductions sur mesure  
 cm Verkleinerung nach Kundenwunsch / disponibles reducciones a medida

**ripiani / shelves / étagères / Böden / estantes**

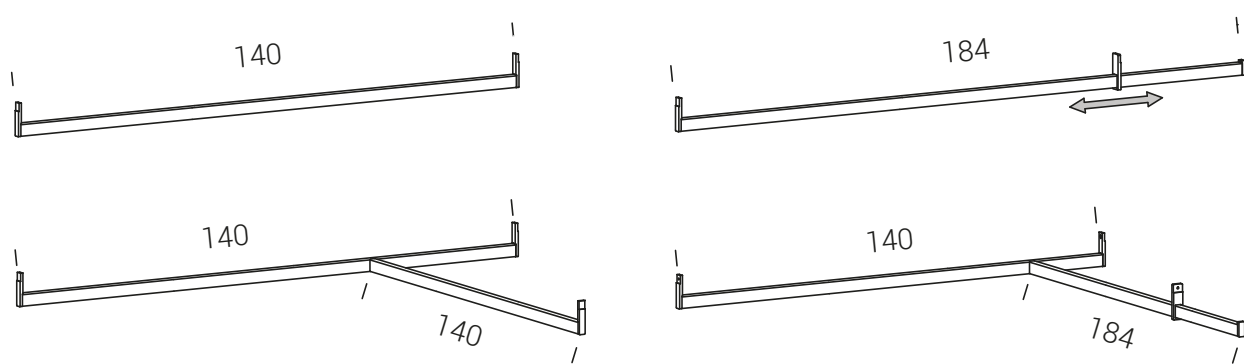

disponibili riduzioni a misura / tailor-made reduction available / disponibles réductions sur mesure  
 cm Verkleinerung nach Kundenwunsch / disponibles reducciones a medida

**ripiani / shelves / étagères / Böden / estantes**

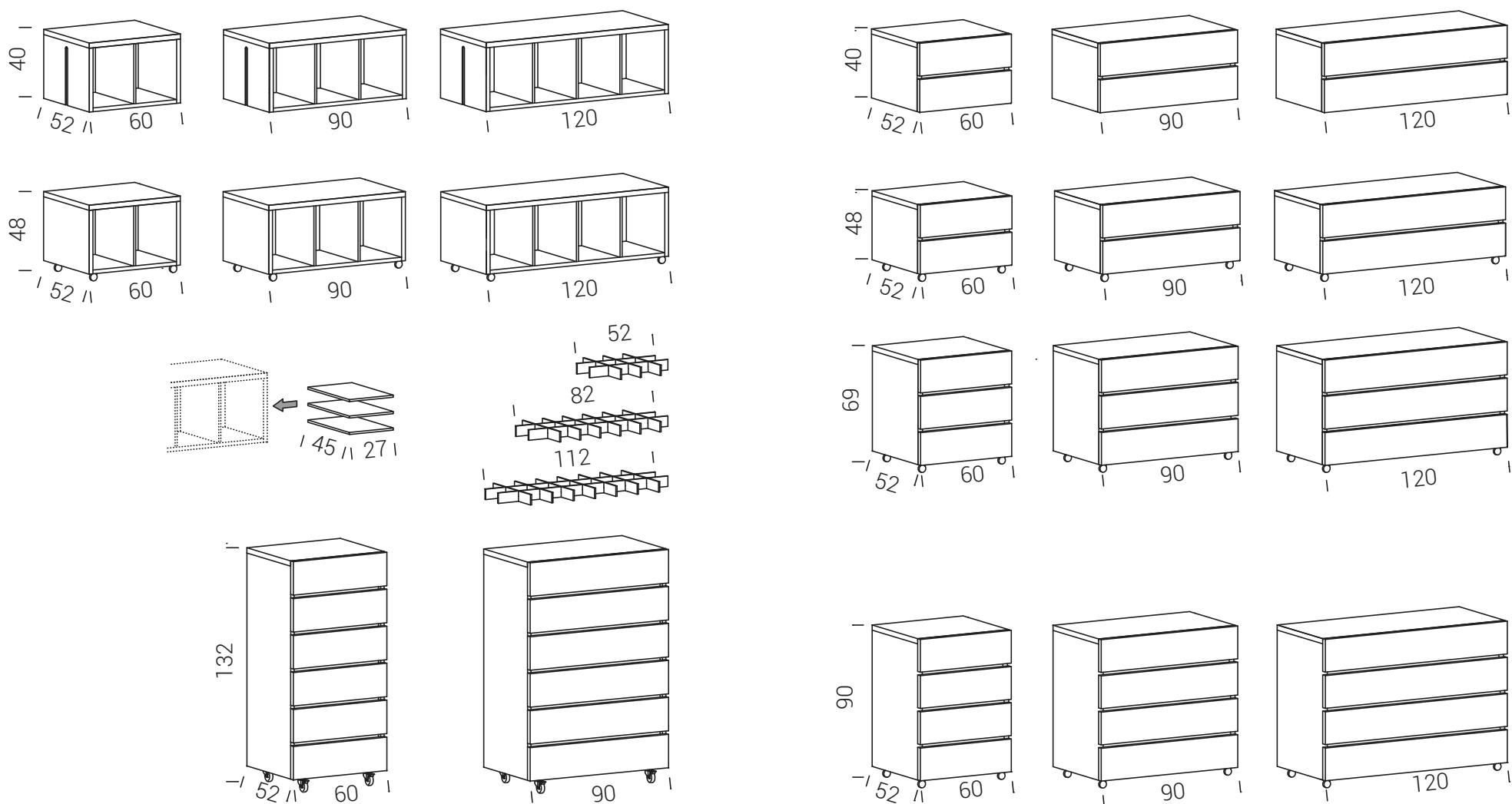

**ripiani portascarpe su ruote / shoe rack shelves on casters / étagères porte-chaussures sur roues  
 Böden schuhablage auf rollen / estantes portazapatos con ruedas**

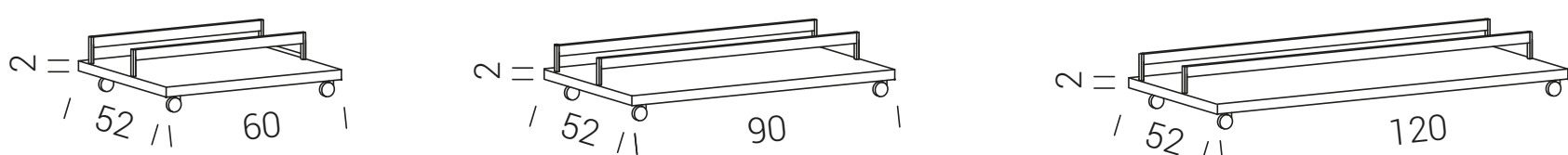

disponibili riduzioni a misura / tailor-made reduction available / disponibles réductions sur mesure  
 cm Verkleinerung nach Kundenwunsch / disponibles reducciones a medida

**portapantaloni / trouser rail / porte-pantalons / Hosenhalter / portapantalones**

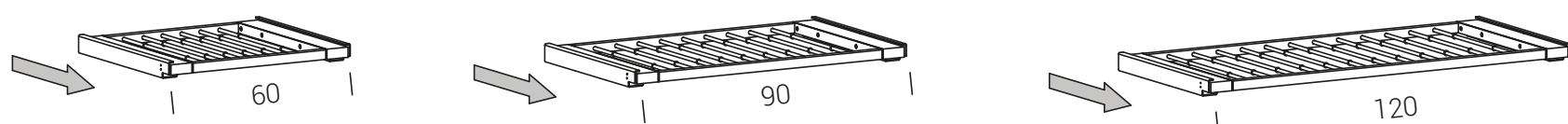



**spalle / support profiles / montants / Widerlage / perchas**

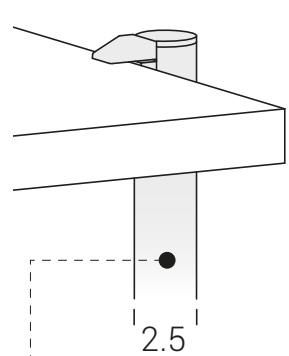
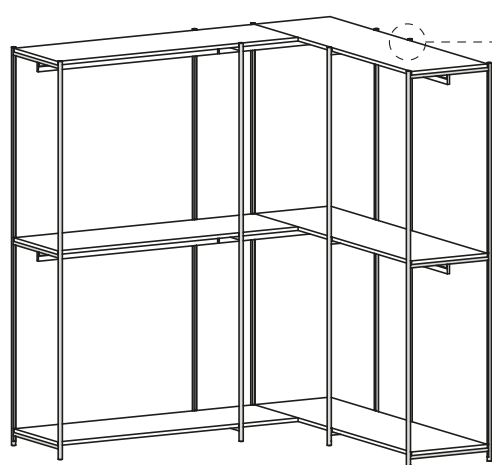

alluminio  
aluminium  
aluminium  
Aluminium  
aluminio

verniciatura a polveri  
powder coating  
peinture en poudres  
Pulverlackierung  
pintura en polvo

|  |            |                    |
|--|------------|--------------------|
|  | <b>C12</b> | bianco<br>white    |
|  | <b>C21</b> | seta<br>silk       |
|  | <b>C30</b> | ghisa<br>cast-iron |
|  | <b>C08</b> | nero<br>black      |

**ripiani / shelves / étagères / Böden / estantes**

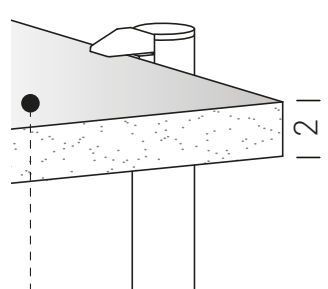
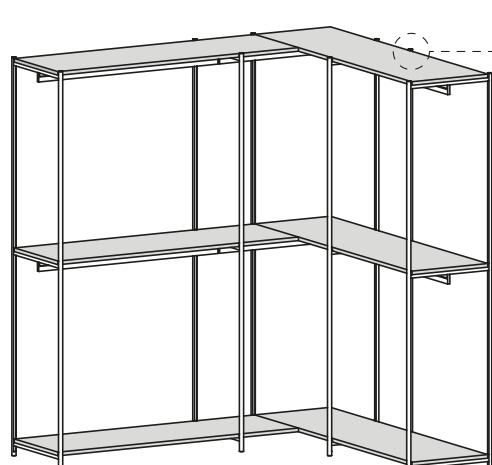

agglomerato ligneo  
wood composite  
aggloméré de bois  
holzartiges Agglomerat  
aglomerado de madera

100 cm => 30 kg

laccato  
lacquered  
laqué  
lackiert  
lacado

|  |            |                    |
|--|------------|--------------------|
|  | <b>Q05</b> | bianco<br>white    |
|  | <b>Q16</b> | seta<br>silk       |
|  | <b>Q17</b> | corda<br>ecru      |
|  | <b>Q20</b> | ghisa<br>cast-iron |
|  | <b>Q04</b> | nero<br>black      |

melaminico  
melamine  
mélaminé  
Melamin  
melamina

|  |            |                         |
|--|------------|-------------------------|
|  | <b>M03</b> | bianco<br>white         |
|  | <b>M02</b> | rovere moka<br>moka oak |

**barre portabiti / clothes rails / barres porte-vêtements / Kleiderstangen / barras perchera**

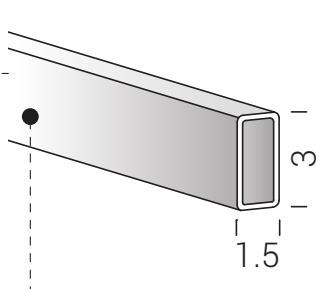
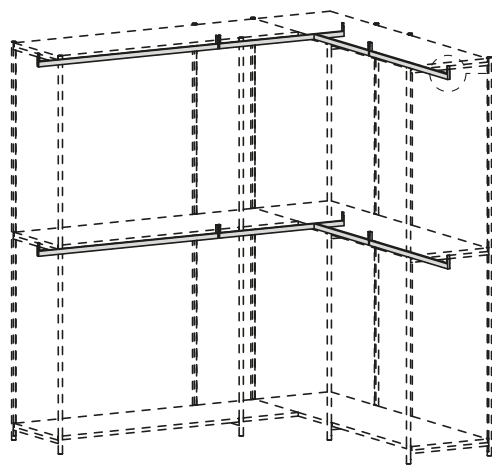

alluminio  
aluminium  
aluminium  
Aluminium  
aluminio

100 cm => 30 kg

verniciatura a polveri  
powder coating  
peinture en poudres  
Pulverlackierung  
pintura en polvo

|  |            |                    |
|--|------------|--------------------|
|  | <b>C12</b> | bianco<br>white    |
|  | <b>C21</b> | seta<br>silk       |
|  | <b>C30</b> | ghisa<br>cast-iron |
|  | <b>C08</b> | nero<br>black      |

**contenitori / cabinets / modules de rangement / Behälter / contenedores**

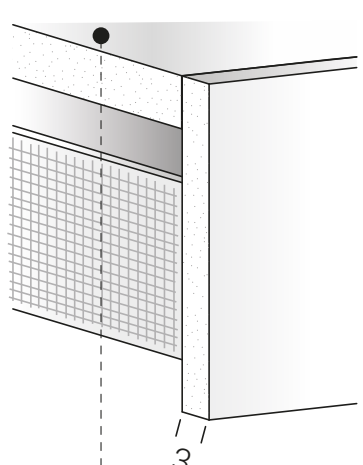
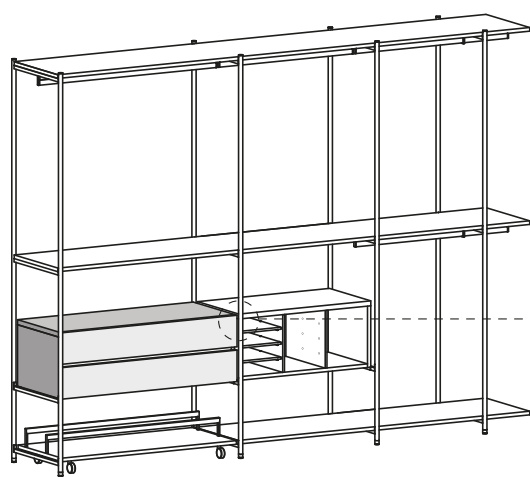

agglomerato ligneo  
wood composite  
aggloméré de bois  
holzartiges Agglomerat  
aglomerado de madera

laccato  
lacquered  
laqué  
lackiert  
lacado

|  |            |                    |
|--|------------|--------------------|
|  | <b>Q05</b> | bianco<br>white    |
|  | <b>Q16</b> | seta<br>silk       |
|  | <b>Q17</b> | corda<br>ecru      |
|  | <b>Q20</b> | ghisa<br>cast-iron |
|  | <b>Q04</b> | nero<br>black      |

melaminico  
melamine  
mélaminé  
Melamin  
melamina

|  |            |                         |
|--|------------|-------------------------|
|  | <b>M03</b> | bianco<br>white         |
|  | <b>M02</b> | rovere moka<br>moka oak |

**ripiani portascarpe su ruote / shoe rack shelves on casters / étagères porte-chaussures sur roues  
Böden schuhablage auf rollen / estantes portazapatos con ruedas**

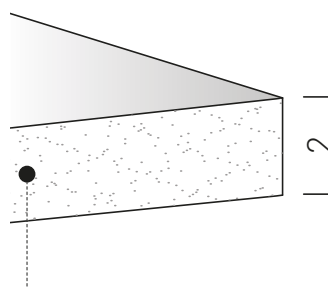
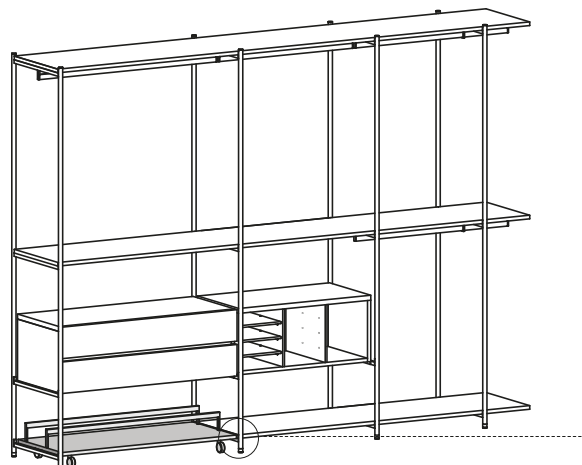

agglomerato ligneo  
wood composite  
aggloméré de bois  
holzartiges Agglomerat  
aglomerado de madera

20 kg/ml

laccato  
lacquered  
laqué  
lackiert  
lacado

|  |            |                    |
|--|------------|--------------------|
|  | <b>Q05</b> | bianco<br>white    |
|  | <b>Q16</b> | seta<br>silk       |
|  | <b>Q17</b> | corda<br>ecru      |
|  | <b>Q20</b> | ghisa<br>cast-iron |
|  | <b>Q04</b> | nero<br>black      |

melaminico  
melamine  
mélaminé  
Melamin  
melamina

|  |            |                         |
|--|------------|-------------------------|
|  | <b>M03</b> | bianco<br>white         |
|  | <b>M02</b> | rovere moka<br>moka oak |

**portapantaloni / trouser rail / porte-pantalons / Hosenhalter / portapantalones**

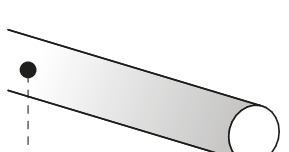

alluminio  
aluminium  
aluminium  
Aluminium  
aluminio

verniciatura a polveri  
powder coating  
peinture en poudres  
Pulverlackierung  
pintura en polvo

|  |            |                    |
|--|------------|--------------------|
|  | <b>C12</b> | bianco<br>white    |
|  | <b>C21</b> | seta<br>silk       |
|  | <b>C30</b> | ghisa<br>cast-iron |
|  | <b>C08</b> | nero<br>black      |





## slide

SL01

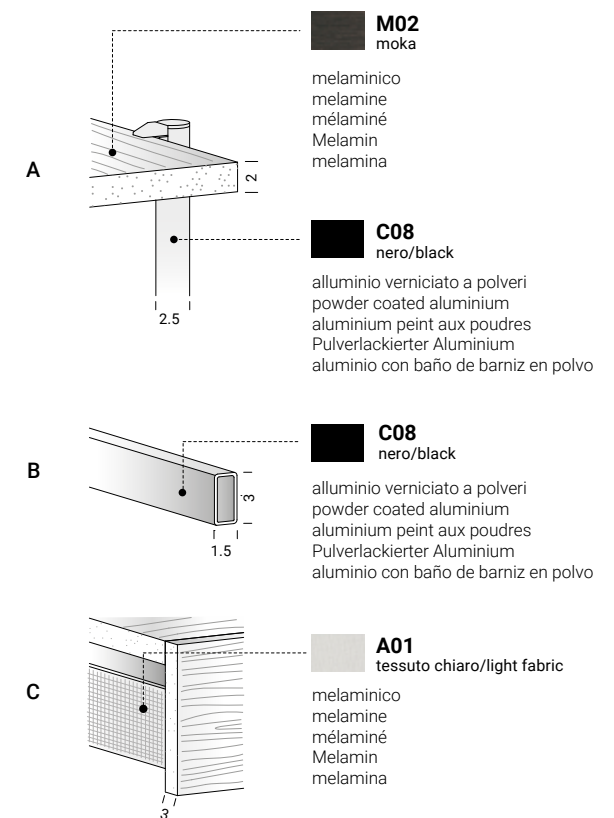
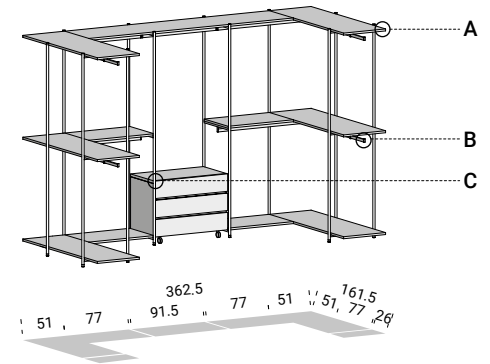

collection info  
pg. 290













## slide SL04

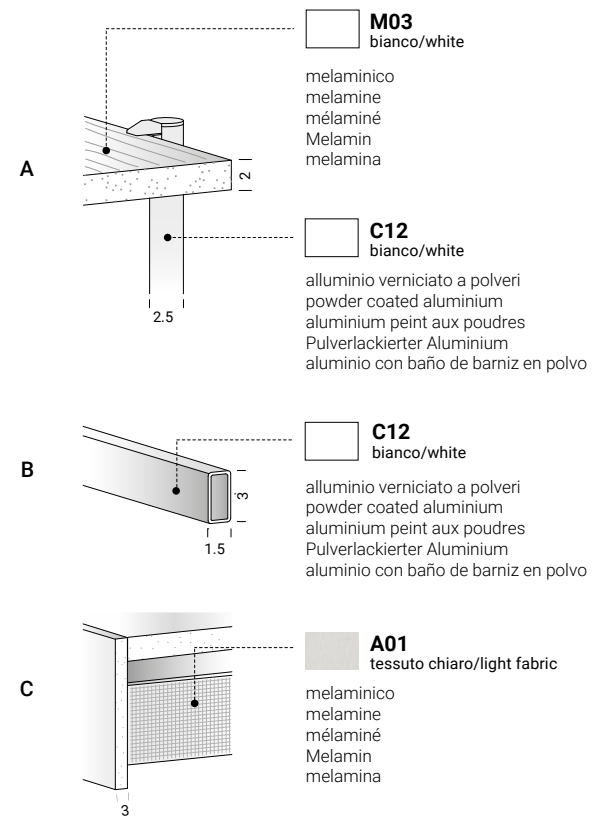
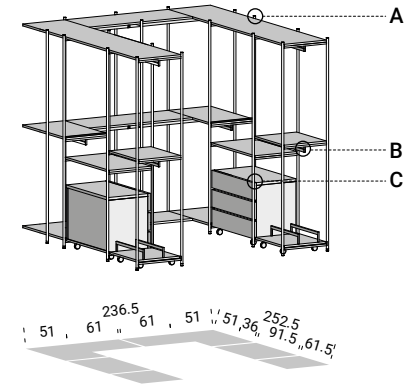













## slide

SL03

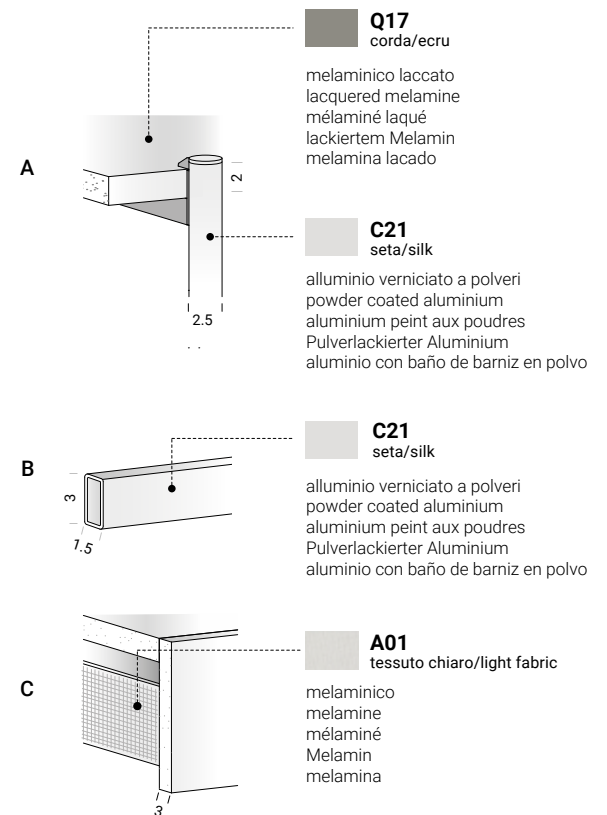
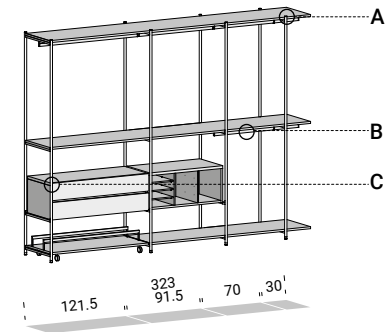

collection info  
pg. 290





## slide SL02

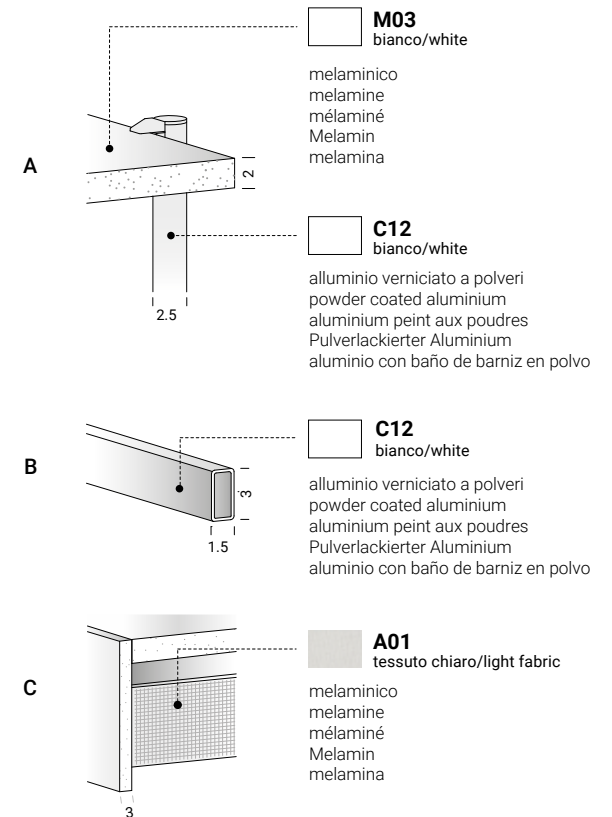
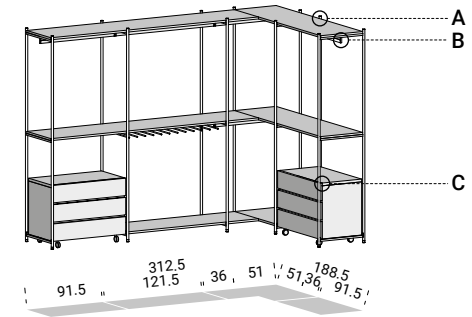

collection info  
pg. 290

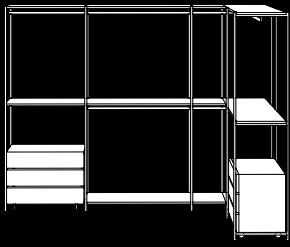

## personal

**Il sistema brevettato extendo è formato da due profili in alluminio estensibili, adattabili alle diverse altezze degli ambienti. Agendo sulla leva a scomparsa, i profili si bloccano all'altezza desiderata e si comprimono tra pavimento e soffitto, senza l'utilizzo di alcun utensile o pre-fissaggio.**

The patented extendo system consists of two extendable aluminium profiles that can be adapted to environments of various heights. Using the foldaway lever, the profiles can be blocked at the desired height and compressed between floor and ceiling, without having to use any kind of pre-fixing tool.

Le système breveté extendo est constitué de deux profilés extensibles en aluminium pouvant être adaptés aux différentes hauteurs des milieux. En agissant sur le levier escamotable, les profilés se verrouillent à la hauteur souhaitée et se compriment entre plancher et plafond, sans utiliser aucun outil ou préfixation.

El sistema patentado extendo está formado por dos perfiles de aluminio extensibles, adaptables a las distintas alturas de los ambientes. Actuando sobre la palanca escondida, los perfiles se bloquean a la altura deseada y se comprimen entre el suelo y el techo, sin que sea necesario utilizar ninguna herramienta o fijación previa.

Das patentierte System extendo besteht aus zwei ausziehbaren Aluminium-Profilen, die an unterschiedliche Raumhöhen angepasst werden können. Durch einen versenkbaren Hebel werden die Profile auf der gewünschten Höhe blockiert und zwischen Fußboden und Zimmerdecke ohne Werkzeug oder Vor-Befestigung komprimiert eingesetzt.



L'asta telescopica extendo esercita una spinta dinamica verso l'alto che consente di assorbire eventuali variazioni d'altezza tra pavimento e soffitto che possono avvenire nel corso del tempo. Per progettare senza vincoli ogni spazio, sono disponibili adattatori soffitto cartongesso, soffitto inclinato e a parete.

The extendo telescopic rod exerts dynamic upward pressure, so that it can absorb any height variations between the floor and ceiling that may occur over time. In order to design any space without limitations, adaptors are available for plasterboard ceilings, sloped ceilings and walls.

La tige télescopique extendo exerce une poussée dynamique vers le haut qui permet d'absorber les éventuelles variations de hauteur entre le plancher et le plafond susceptibles de se présenter au fil du temps. Pour concevoir tout espace sans contraintes, des adaptateurs pour plafond en placoplâtre, plafond incliné et pour application murale sont disponibles.

## personal materials



alluminio  
aluminium  
Aluminium  
aluminio

Le materie prime che costituiscono il sistema personal derivano da un processo di riutilizzo e sono a loro volta riciclabili.

The primary materials used in the personal "system" are sourced from a reuse process, and are in turn recyclable.

Les matières premières qui composent le système personal dérivent d'un processus de réutilisation et sont à leur tour recyclables.

Die Rohstoffe für das System personal entstammen einem Wiederverwertungsprozess und sind Ihrerseits wiederum recyclebar.

Las materias primas que constituyen el sistema personal proceden de un proceso de reutilización y son, a su vez, reciclables.

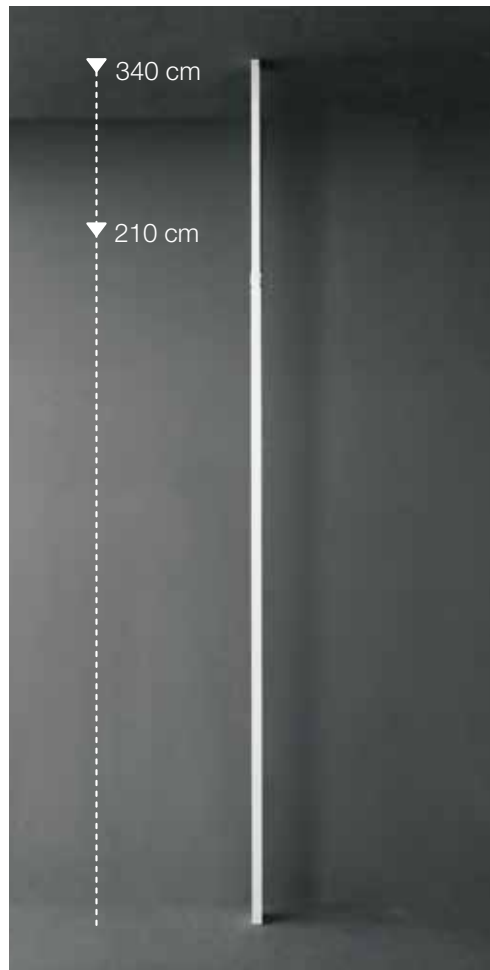

Die Teleskopstange extendo übt einen dynamischen Druck nach oben aus, wodurch mögliche Änderungen des Abstands zwischen Boden und Decke, wie sie im Lauf der Zeit auftreten können, aufgefangen werden. Um jeden Raum ohne Einschränkungen planen zu können, sind Adapter zur Befestigung an Decken aus Gipskarton, Dachschrägen und an Wänden erhältlich.

La barra telescópica extendo ejerce un empuje dinámico hacia arriba que permite absorber las variaciones de altura entre el suelo y el techo que se pueden dar con el tiempo. Para diseñar sin limitaciones cualquier espacio, existen adaptadores de cartón-yeso para techo, techo inclinado y pared.

Profilo extendo con attacco a parete disponibile in tre altezze o con supporto a pavimento autoportante.

Extendo profile with wall couplung available in three heights or with freestanding floor support.

Profilé extendo avec fixation murale disponible en trois hauteurs ou avec support au sol autoportant.

Das extendo Profil mit Wandbefestigung steht in drei verschiedenen Höhen oder mit selbsttragender Bodenhalterung zur Verfügung.

Perfil extendo con sujeción a pared disponible en tres alturas y con soporte autónomo al suelo.



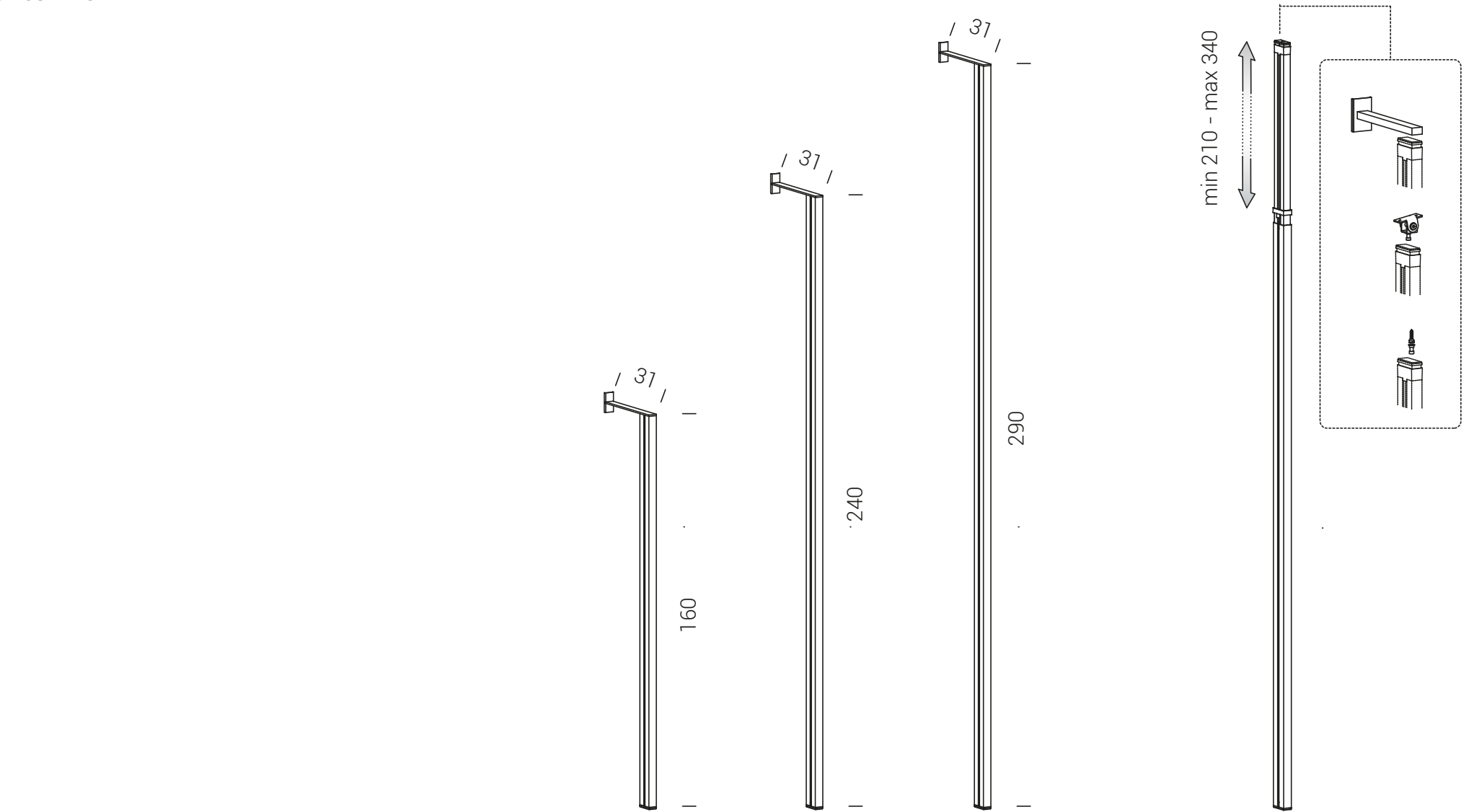

disponibili riduzioni a misura / tailor-made reduction available / disponibles réductions sur mesure  
 Verkleinerung nach Kundenwunsch / disponibles reducciones a medida

ripiani / shelves / étagères / Böden / estantes

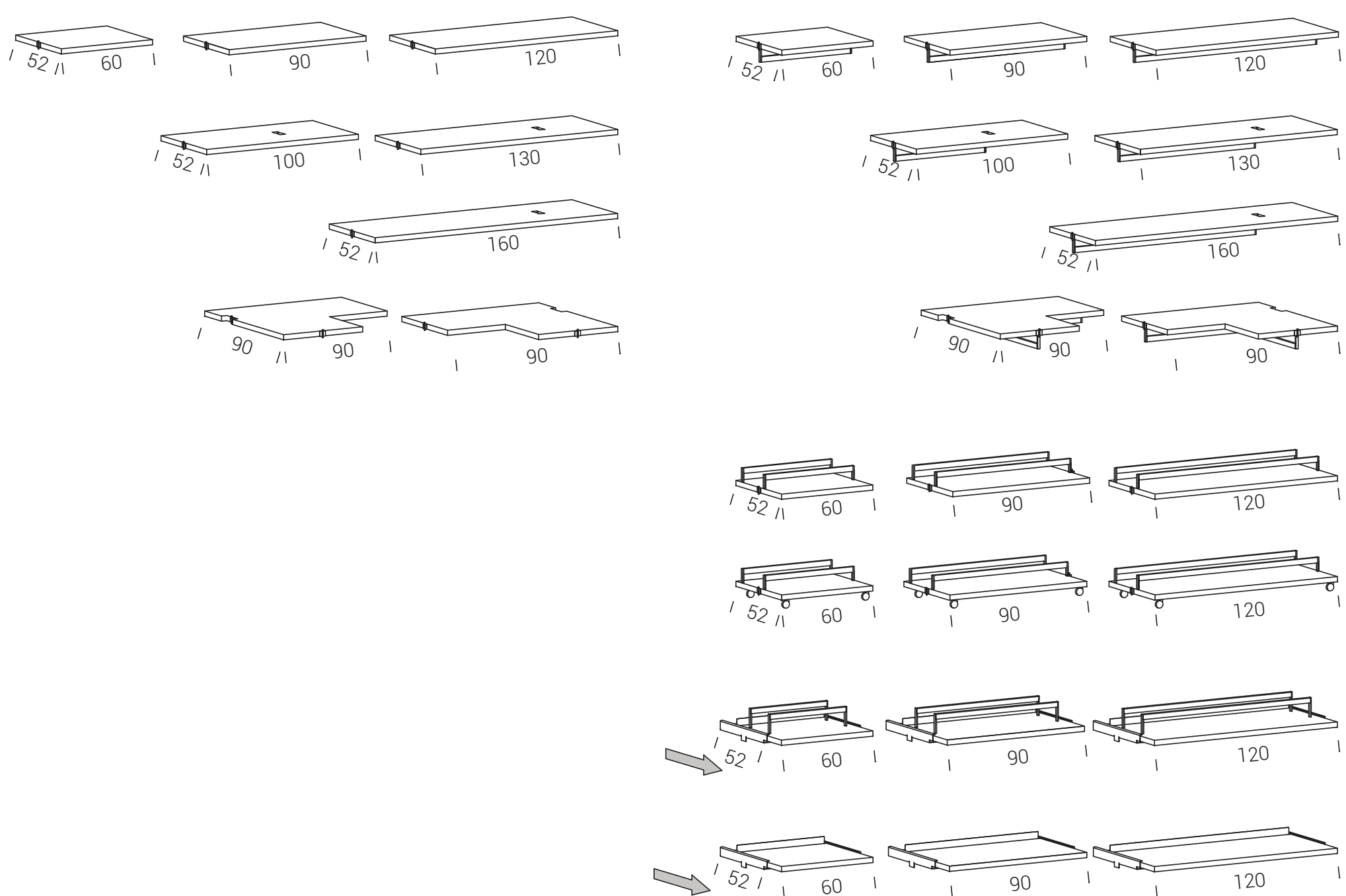

disponibili riduzioni a misura / tailor-made reduction available / disponibles réductions sur mesure  
 Verkleinerung nach Kundenwunsch / disponibles reducciones a medida

ripiani in vetro / glass shelves / étagères en verre / Böden aus glas / estantes de cristal

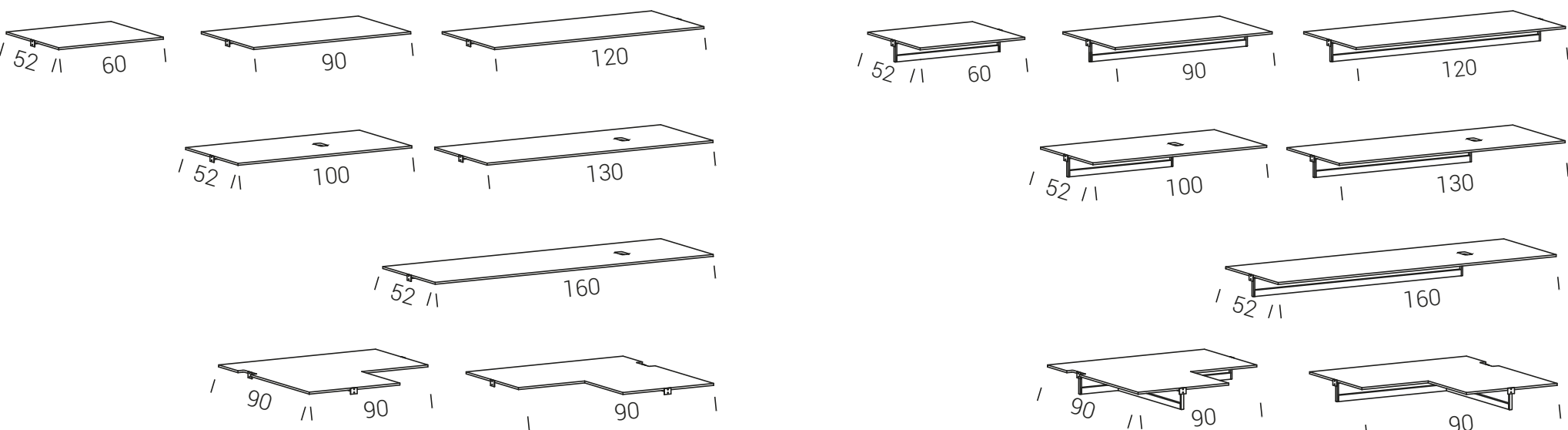

disponibili riduzioni a misura / tailor-made reduction available / disponibles réductions sur mesure  
 Verkleinerung nach Kundenwunsch / disponibles reducciones a medida

contenitori / cabinets / modules de rangement / Behälter / contenedores

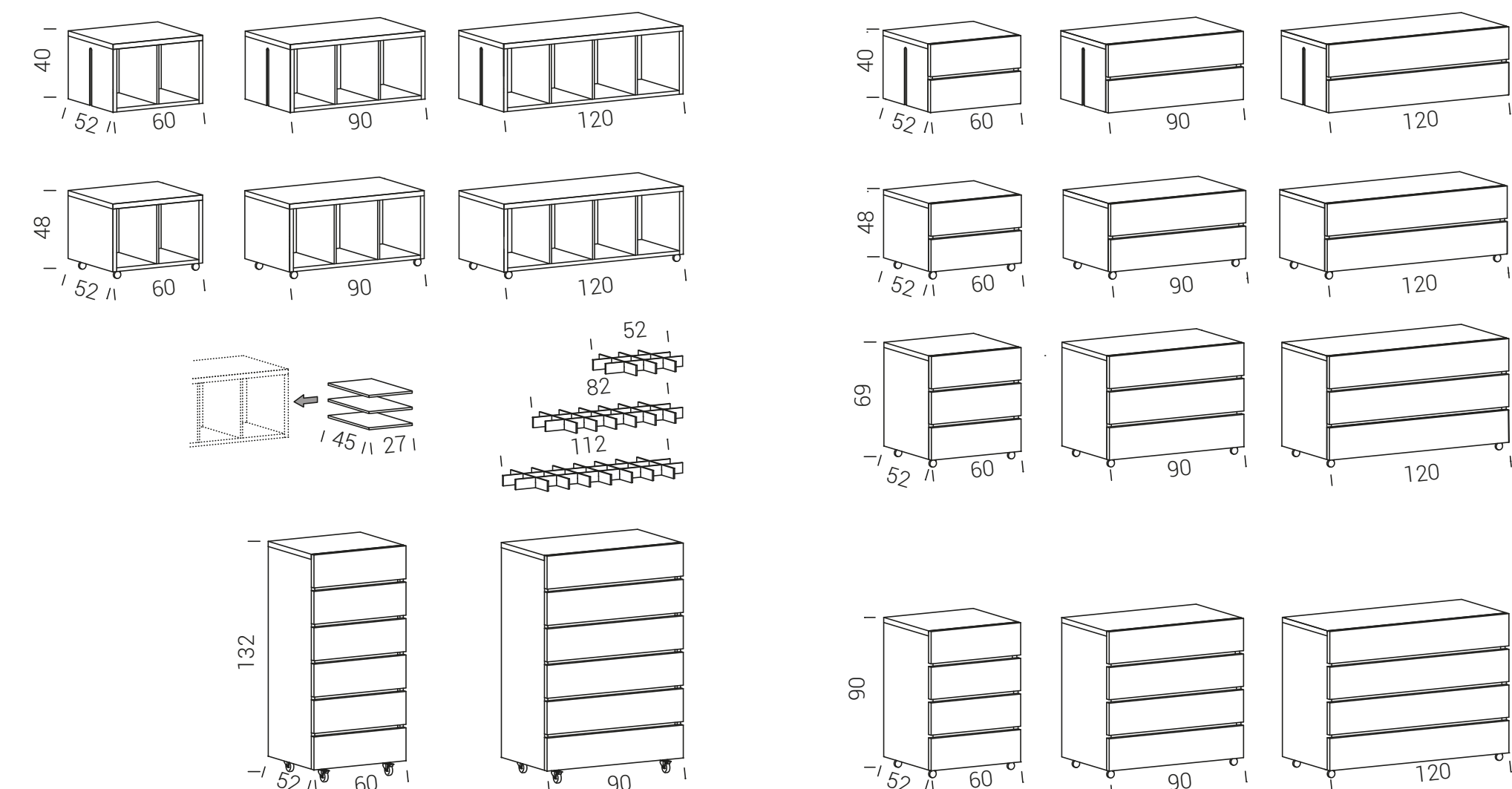

accessori / accessories / accessoires / Zubehör / accesorios

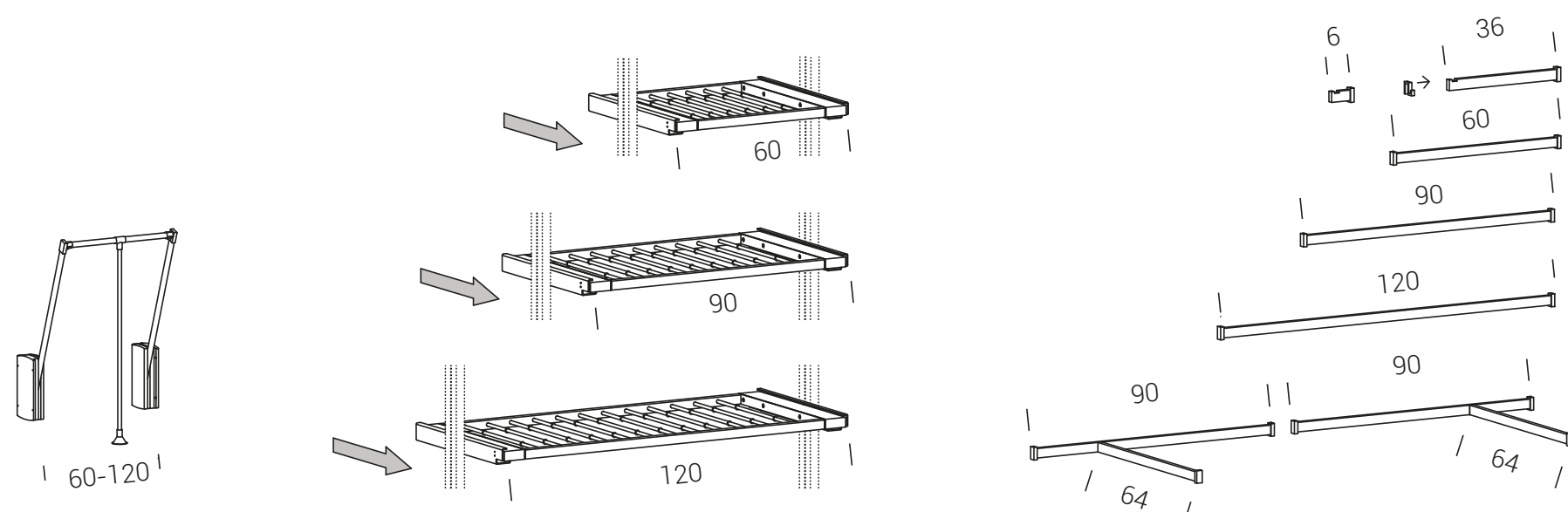

**extendo**

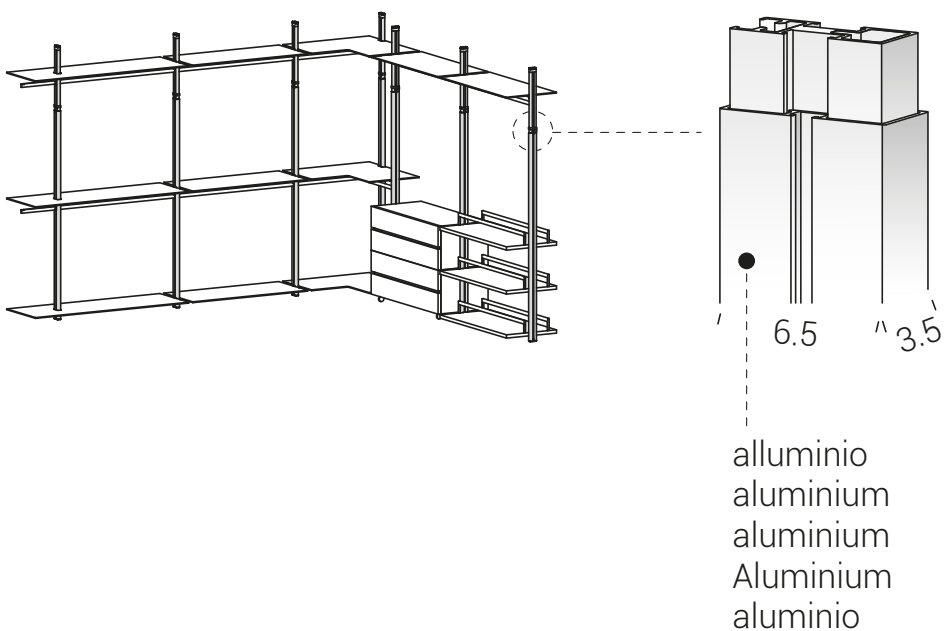

verniciatura a polveri  
powder coating  
peinture en poudres  
Pulverlackierung  
pintura en polvo

-  **C12** bianco white
-  **C21** seta silk
-  **C30** ghisa cast-iron
-  **C08** nero black

**ripiani / shelves / étagères / Böden / estantes**

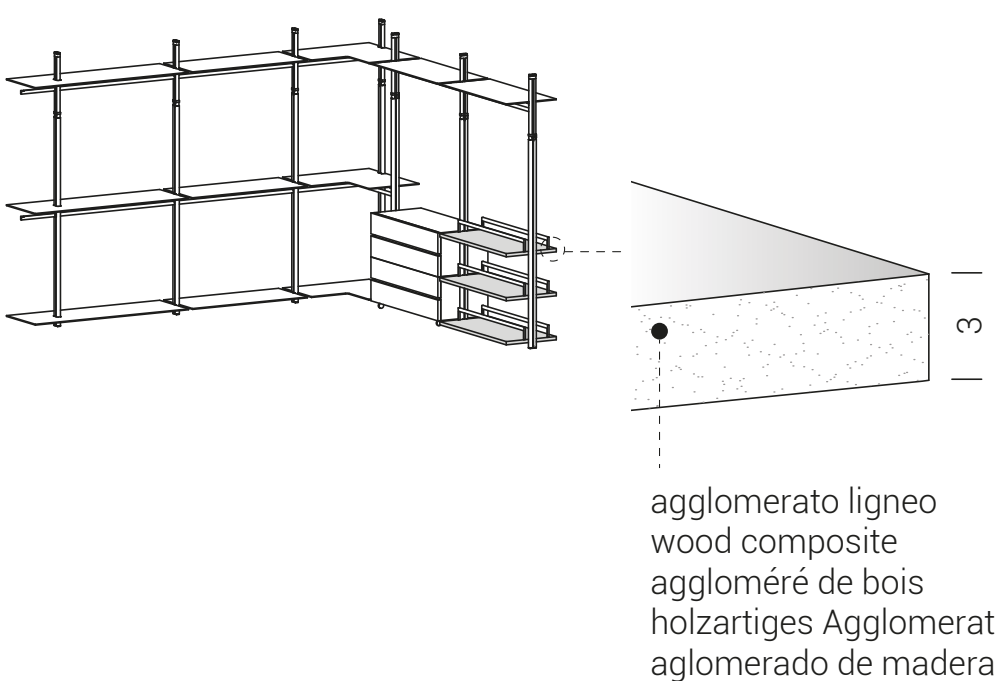



laccato  
lacquered  
laqué  
lackiert  
lacado

-  **Q05** bianco white
-  **Q16** seta silk
-  **Q17** corda ecru
-  **Q20** ghisa cast-iron
-  **Q04** nero black

 20 kg/ml

melaminico  
melamine  
mélaminé  
Melamin  
melamina

-  **M03** bianco white
-  **M02** rovere moka moka oak

**ripiani in vetro / glass shelves / étagères en verre / Böden aus glas / estantes de cristal**

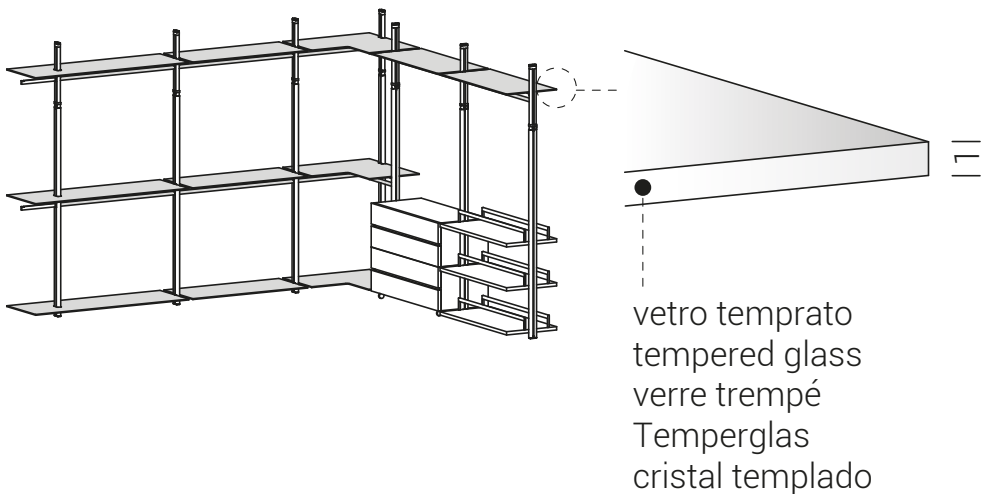

laccato  
lacquered  
laqué  
lackiert  
lacado

-  **V01** bianco white
-  **V15** seta silk
-  **V16** corda ecru
-  **V23** ghisa cast-iron
-  **V02** nero black

 25 kg/ml

-  **V06** fumè smoked glass

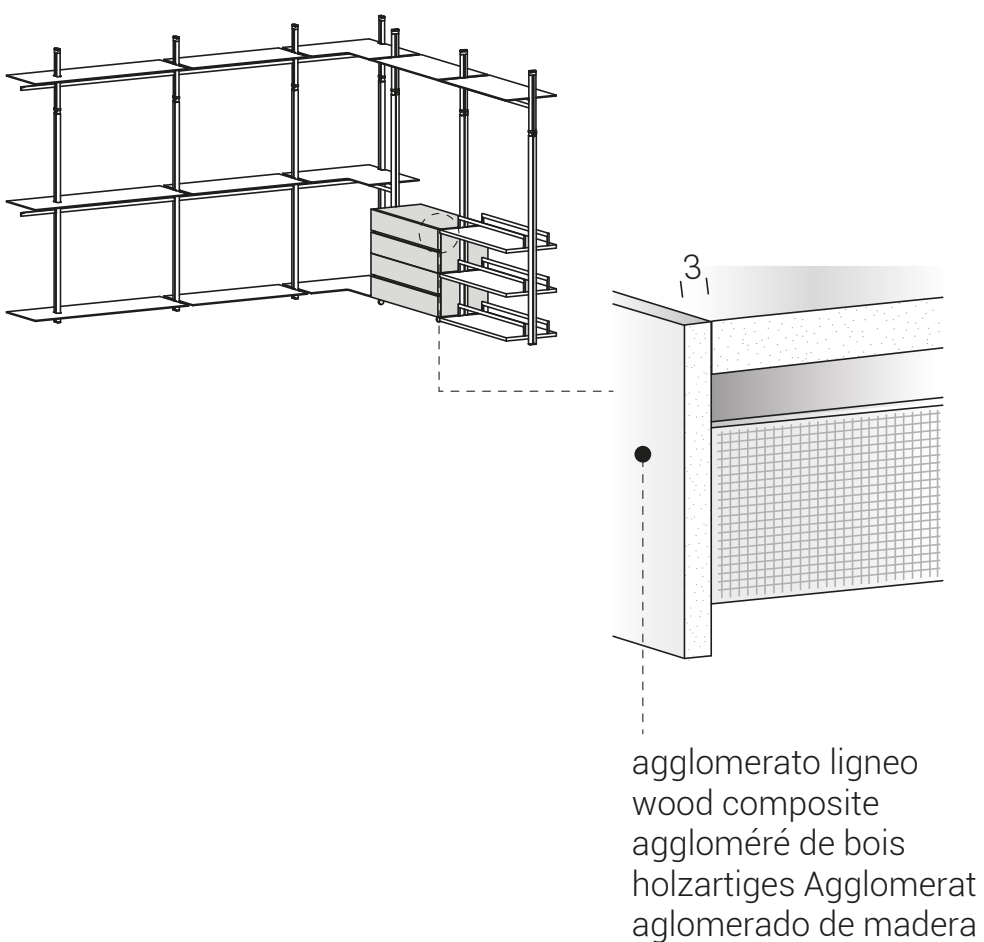

**contenitori / cabinets / modules de rangement / Behälter / contenedores**



laccato  
lacquered  
laqué  
lackiert  
lacado

-  **Q05** bianco white
-  **Q16** seta silk
-  **Q17** corda ecru
-  **Q20** ghisa cast-iron
-  **Q04** nero black



melaminico  
melamine  
mélaminé  
Melamin  
melamina

-  **M03** bianco white
-  **M02** rovere moka moka oak

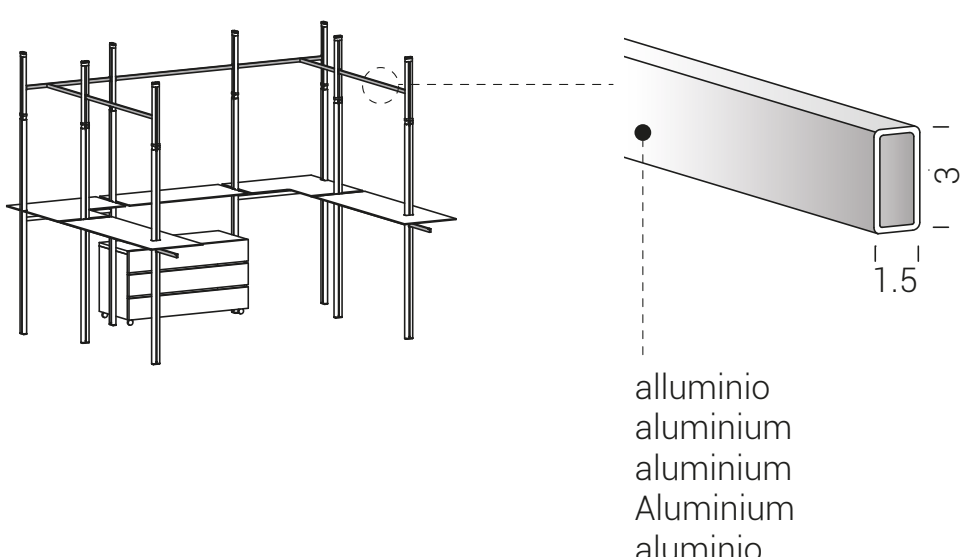
**accessori / accessories / accessoires / Zubehör / accesorios**

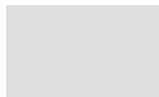

verniciatura a polveri  
powder coating  
peinture en poudres  
Pulverlackierung  
pintura en polvo

-  **C12** bianco white
-  **C21** seta silk
-  **C30** ghisa cast-iron
-  **C08** nero black





## personal

PE01

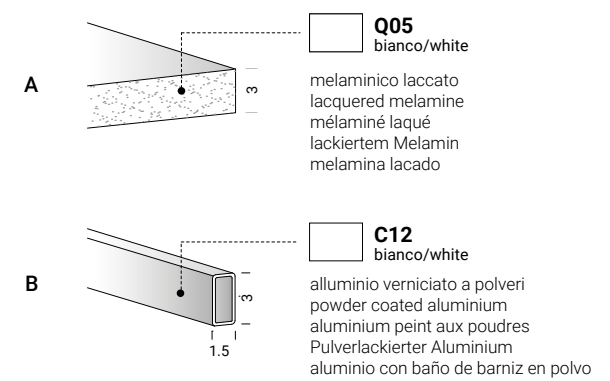
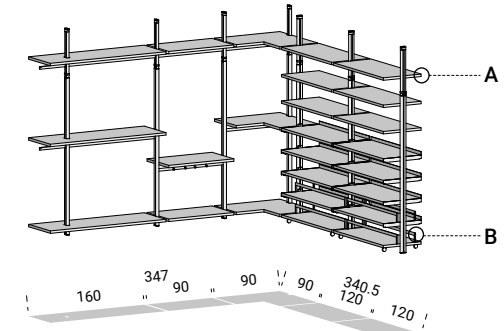

collection info  
pg. 306













## personal PE02

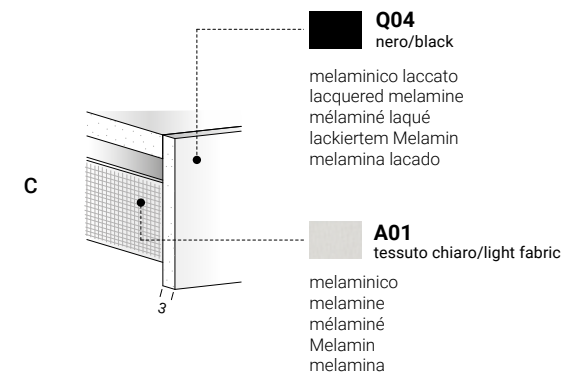
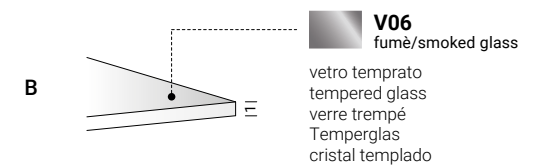
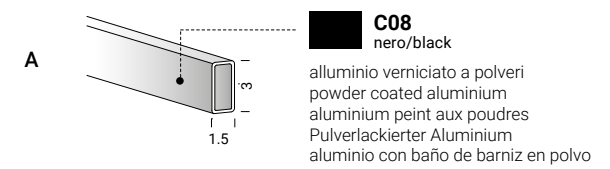
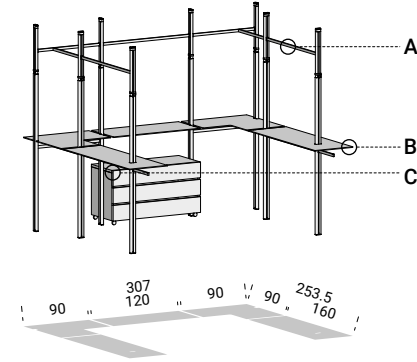



I ripiani in vetro adottano un esclusivo sistema d'attacco su supporti in alluminio ad incollaggio UV. Il sistema ad incollaggio impedisce ogni contatto diretto con l'asta estensibile. I ripiani in vetro sono disponibili in tutti i moduli della collezione personal, 60/90/120 e ad angolo con o senza barra porta abiti.

The glass shelves have an exclusive mounting system on aluminium supports with UV bonding. The bonding system prevents direct contact with the extendable bar.

The glass shelves are available in all the modules of the personal collection, 60/90/120 and for the corner unit with or without a clothes rail.

Les étagères en verre adoptent un système d'attelage exclusif sur des supports en aluminium à collage UV. Le système à collage empêche tout contact direct avec la tige étirable. Les étagères en verre sont disponibles dans tous les modules de la collection personal, 60/90/120 et à angle avec ou sans barre porte-vêtements.

Die Glasregale haben ein eigenes Befestigungssystem auf Aluminiumhaltern mit UV-Klebung. Das Klebesystem verhindert jeglichen direkten Kontakt mit der ausdehnbaren Stange. Die Glasregale sind in allen Modulen der Personal Kollektion erhältlich, 60/90/120 und mit Winkel, mit oder ohne Kleidungsstange.

Las repisas de vidrio adoptan un sistema de enganche exclusivo en soportes de aluminio mediante encolado UV. El sistema de encolado impide cualquier contacto directo con la barra extensible. Las repisas de vidrio se encuentran disponibles en todos los módulos de la colección personal, 60/90/120 y en ángulo con o sin barra percha para prendas de vestir.

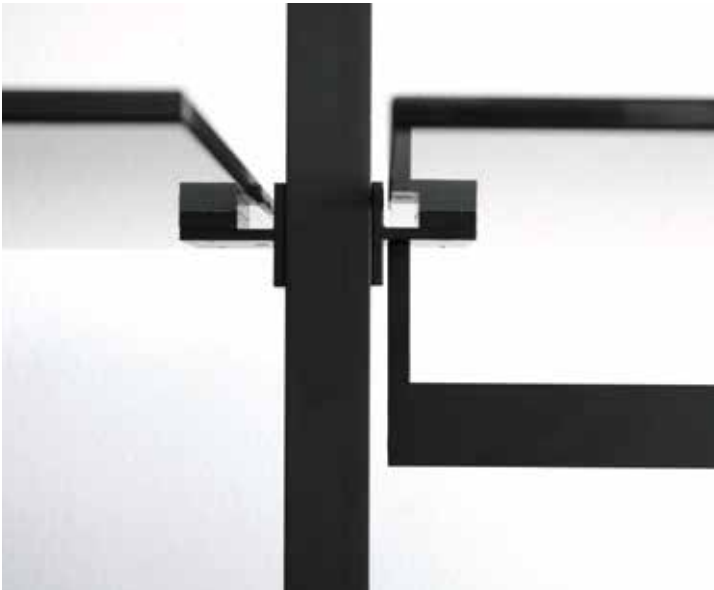









## personal

PE03

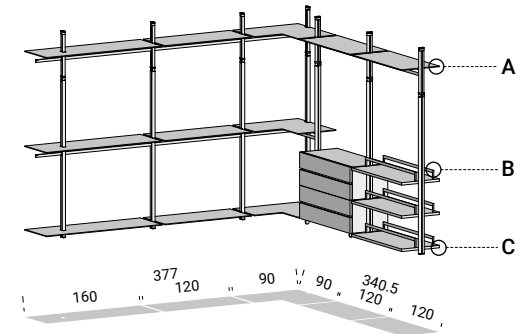

- A**
- V01**  
bianco/white
- vetro temprato laccato  
lacquered tempered glass  
verre trempé laqué  
lackiertem Temperglas  
cristal templado lacado
- B**
- C12**  
bianco/white
- alluminio verniciato a polveri  
powder coated aluminium  
aluminium peint aux poudres  
Pulverlackierter Aluminium  
aluminio con baño de barniz en polvo
- C**
- Q05**  
bianco/white
- melaminico laccato  
lacquered melamine  
mélaminé laqué  
lackiertem Melamin  
melamina lacado

collection info  
pg. 306











## personal PE04

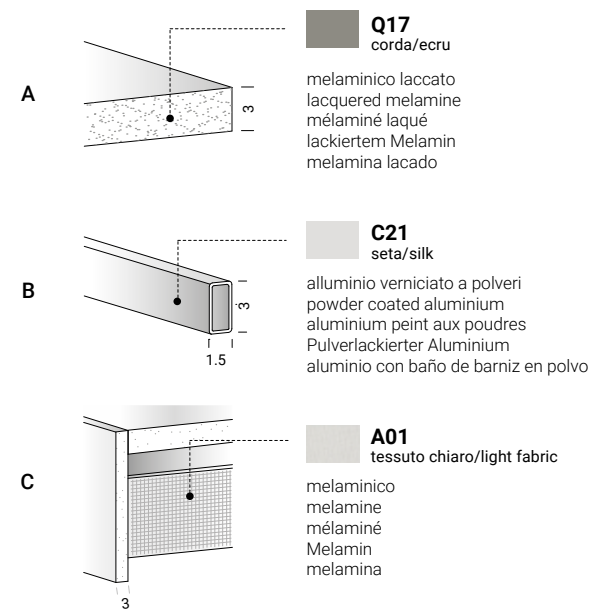
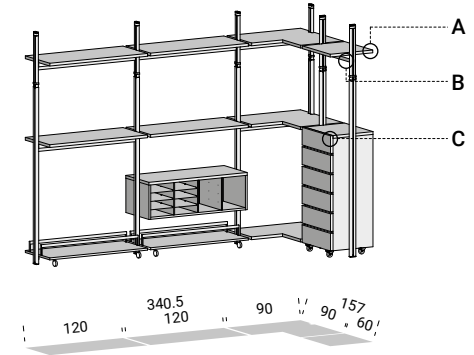

collection info  
pg. 306





## personal PE05

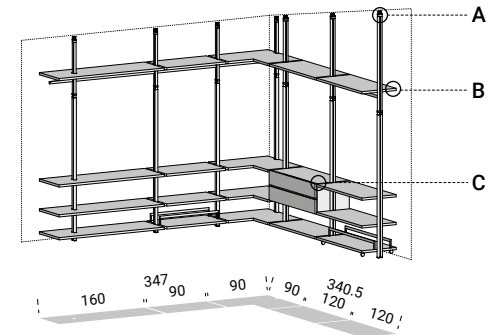

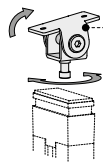
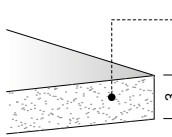
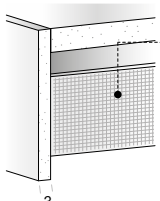
- A**
- 
- C12**  
bianco/white  
acciaio verniciato a polveri  
powder coated steel  
acier peint aux poudres  
Pulverlackierter Stahl  
Acero con baño de barniz en polvo
- B**
- 
- Q05**  
bianco/white  
melaminico laccato  
lacquered melamine  
mélaminé laqué  
lackiertem Melamin  
melamina lacado
- C**
- 
- A01**  
tessuto chiaro/light fabric  
melaminico  
melamine  
mélaminé  
Melamin  
melamina

collection info  
pg. 306





**personal**  
PE06

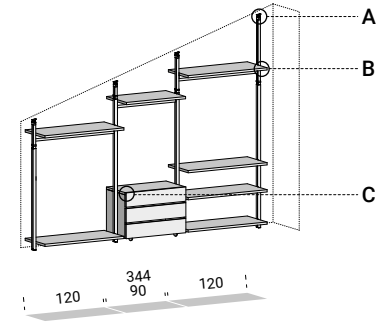

**A**

**C21**  
seta/silk

acciaio verniciato a polveri  
powder coated steel  
acier peint aux poudres  
Pulverlackierter Stahl  
Acero con baño de barniz en polvo

**B**

**Q17**  
corda/ecru

melaminico laccato  
lacquered melamine  
mélaminé laqué  
lackiertem Melamin  
melamina lacado

**C**

**A01**  
tessuto chiaro/light fabric

melaminico  
melamine  
mélaminé  
Melamin  
melamina

collection info  
pg. 306







## personal

PE07

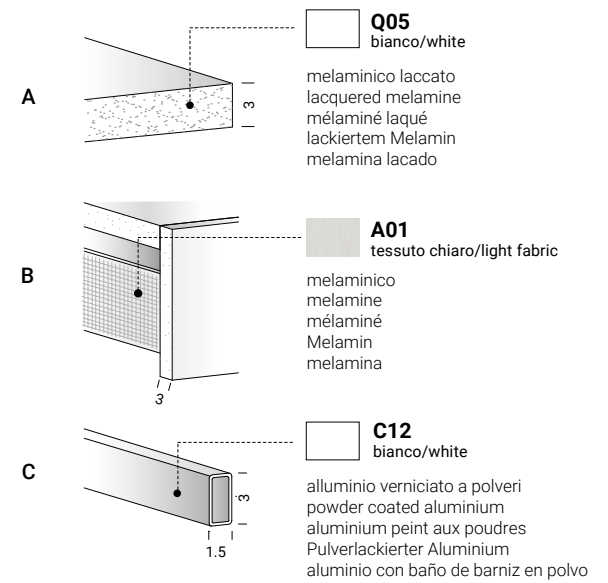
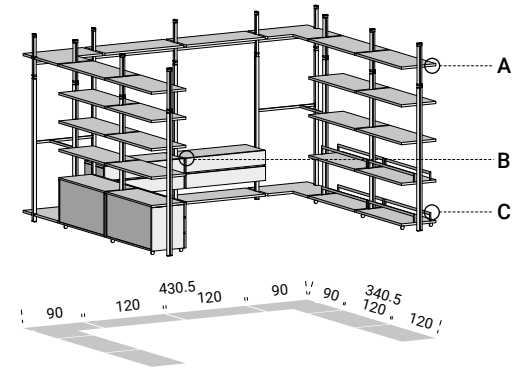

collection info  
pg. 306





Le barre porta abiti in alluminio sono disponibili in tutti i moduli della collezione personal, 60/90/120 e ad angolo, agganciate al ripiano o direttamente al profilo estensibile, finitura C04 alluminio silver.

The aluminium clothes rails are available for all the modules of the personal collection, 60/90/120 and corner unit, hooked to the shelf or directly to the extendable profile, with a silver C04 aluminium finish.

Les barres porte-vêtements en aluminium sont disponibles dans tous les modules de la collection personal, 60/90/120 et à angle, accrochées soit à l'étagère soit directement au profil étirable, finition C04 aluminium silver.

Die Kleidungsstangen aus Aluminium sind in allen Modulen der Personal Kollektion erhältlich, 60/90/120 und mit Winkel, die am Regalbrett angebracht sind, oder direkt am ausdehnbaren Profil, in Silber-Aluminium C04 Endbearbeitung.

Las perchas para prendas de vestir de aluminio se encuentran disponibles en todos los módulos de la colección personal, 60/90/120 y en ángulo, enganchadas en la repisa o directamente en el perfil extensible, con acabado C04 aluminio silver.







## personal

PE08

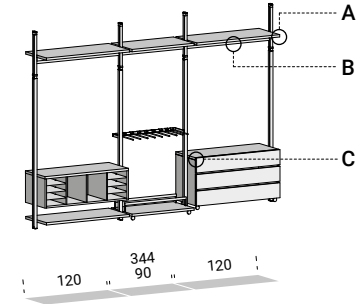

- A**
- M02**  
moka
- melaminico laccato  
lacquered melamine  
mélaminé laqué  
lackiertem Melamin  
melamina lacado
- B**
- C21**  
seta/silk
- alluminio verniciato a polveri  
powder coated aluminium  
aluminium peint aux poudres  
Pulverlackierter Aluminium  
aluminio con baño de barniz en polvo
- C**
- A01**  
tessuto chiaro/light fabric
- melaminico  
melamine  
mélaminé  
Melamin  
melamina

collection info  
pg. 306



**personal**  
PE09

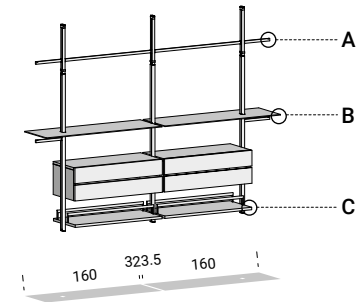

**A**

**C12**  
bianco/white

alluminio verniciato a polveri  
powder coated aluminium  
aluminium peint aux poudres  
Pulverlackierter Aluminium  
aluminio con baño de barniz en polvo

**B**

**V01**  
bianco/white

vetro temprato laccato  
lacquered tempered glass  
verre trempé laqué  
lackiertem Temperglas  
cristal templado lacado

**C**

**Q05**  
bianco/white

melaminico laccato  
lacquered melamine  
mélaminé laqué  
lackiertem Melamin  
melamina lacado

collection info  
pg. 306

---

**art direction**

extendo design dept.

**photo post-production**

extendo design dept.

marigraf.it

**graphic layout**

marigraf.it



via Del Lavoro 2  
35010 Trebaseleghe PD - Italy

tel. +39 049 9387633  
fax +39 049 9387644

www.extendoweb.com  
info@extendoweb.com



extendo ©  
ESTV0079